

"Apollo"[®]

INSTALLATION, OPERATION & MAINTENANCE MANUAL

REDUCED PRESSURE PRINCIPLE (RPZ) 1/4" - 10"

REDUCED PRESSURE DETECTOR ASSEMBLY (RPDA) 3" - 10"

40-200 Series (1/4" - 10") | 40-200S Series (1/4" - 1") | 40-700 Series (3" - 10")

ES1593 IOM BFMM4000 rev.b

SECTION	DESCRIPTION	PAGE
I	Description and Operation	2
II	Installation	3
III	Troubleshooting Guide	4
IV	Maintenance Instructions 1/4" - 2"	5
V	Maintenance Instructions 2-1/2" - 10"	6
VI	Testing Procedures 1/4" - 10"	7-10
Parts List		
	1/4" - 2" Bronze	11-12
	1/4" - 1" Stainless Steel	13-14
	2-1/2" - 10" Ductile Iron	15-20
	3" - 10" RPDA	21-24
Test Kits		
		26

I. DESCRIPTION AND OPERATION

The RPZ device consists of two independently acting, spring loaded, poppet type check valves, together with a hydraulically dependent, mechanically independent pressure differential relief valve, located in the zone between the check valves. Two resilient seated shut-off valves and four test cocks complete the assembly. During normal operation, the pressure drop across the first check valve into the "zone" area is approximately 7 PSI. The second check valve is lightly spring loaded to provide a minimum pressure drop of 1 PSI across it. (See Fig. 1) The relief valve operates on a differential pressure. Supply pressure on the upstream side of the first check valve acts against the diaphragm to close the relief valve during normal operation. In the event of back-pressure, the relief valve will open to maintain the pressure in the "zone" at least 2 PSI less than the inlet pressure. The RPDA device consists of a mainline RPZ and a by-pass assembly consisting of an approved RPZ assembly and water meter. Each device is equipped with test cocks for periodic field testing and is normally supplied with inlet and outlet shut-off valves. For information on operation, installation, trouble shooting & testing refer to Installation Instruction Booklet I503600 furnished with each RPDA unit. For maintenance instructions see pages 5 & 6. For parts list see pages 21 - 24.

FIGURE 1
NO FLOW CONDITION

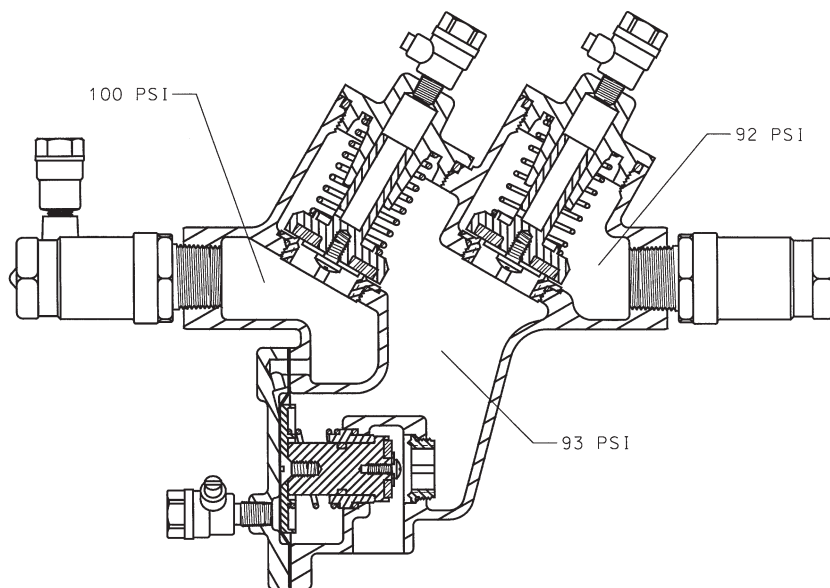

II. INSTALLATION

1. The RPZ device must be installed in an accessible location to facilitate periodic field testing and maintenance.
2. The location selected should have adequate drainage for relief valve discharge. Drainage may be piped away, providing an approved air gap device is used (see Fig. 2). The device should never be placed where it may become submerged in standing water.
3. Flush all upstream piping thoroughly to remove foreign matter prior to installing the device.
4. Install the device in a horizontal position with adequate clearance from walls and/or obstructions, for testing and maintenance. A 12" to 30" clearance between the lower most portion of the device and flood grade or floor should be provided.
5. When shut-off valves are supplied separately, they should be installed with a test cock on the upstream side of the inlet shut-off valve. (f) A "Y" strainer can be installed just upstream of the RPZ assembly to eliminate any debris from entering the device and fouling the check and/or relief valve.
6. When installing the assembly, use pipe sealant on external threads only (if applicable).
7. Use wrench grips provided when installing (if applicable).
8. After installing the assembly, and with downstream or #2 shut-off valve closed, pressurize the RPZ device and bleed air through test cock #4. Then open #2 shut-off valve.

NOTE: If water continues to drain from the relief valve, check the Troubleshooting

III. TROUBLESHOOTING

SYMPTOM	CAUSE	CORRECTIVE ACTION
Relief valve continuously discharges during no-flow condition.	<ol style="list-style-type: none"> #1 check valve fouled with debris. #2 check valve fouled with debris coupled with a back-pressure condition. #1 check poppet stem not moving freely in guide (or #2 check poppet during a back-pressure condition.) 	<ol style="list-style-type: none"> Close #2 shut-off valve or inspect for possible through leakage. Inspect and clean seat disc and seat. Inspect for debris or deposit on poppet stem or guide.
Relief valve discharges continuously during flow and no-flow conditions.	<ol style="list-style-type: none"> Relief valve fouled with debris. Damaged diaphragm (allows water to pass through from inlet to zone). Sensing passage to inlet side of diaphragm plugged. d. #1 check poppet stem not moving freely in poppet guide. 	<ol style="list-style-type: none"> Inspect and clean relief valve seat disc and seat. Replace diaphragm. Inspect and clean passage in cover and body. Inspect for debris or deposits on poppet stem or guide.
Relief valve discharges intermittently in a "spitting" action during no-flow condition.	<ol style="list-style-type: none"> Pressure fluctuations (water hammer) from supply. 	<ol style="list-style-type: none"> Eliminate or reduce pressure fluctuations.
Relief valve does not open during field test No. 1.	<ol style="list-style-type: none"> #2 shut-off valve not closed completely. Test equipment improperly installed. 	<ol style="list-style-type: none"> Close #2 shut-off valve or inspect for possible through leakage. Recheck test procedure.
#2 check valve fails to hold back-pressure.	<ol style="list-style-type: none"> #2 shut-off valve not closed completely. #2 check valve fouled with debris. #2 check poppet stem not moving freely in guide. 	<ol style="list-style-type: none"> Close #2 shut-off valve or inspect for possible through leakage. Inspect and clean seat disc and seat. Inspect for debris or deposits on poppet stem or guide.
Pressure differential across #1 check valve is low during field test No. 3 (must be a minimum of 3 PSI more than the opening differential pressure of the relief valve as recorded in Test No. 1).	<ol style="list-style-type: none"> #1 check valve fouled with debris. Upstream pressure fluctuations causing inaccurate gauge reading. #1 check poppet stem not moving freely in guide. 	<ol style="list-style-type: none"> Inspect and clean seat disc and seat. Eliminate pressure fluctuations. Inspect for debris or deposits on poppet stem or guide.

IV. MAINTENANCE INSTRUCTIONS - 1/4" - 2"

A. DISASSEMBLY — CHECK VALVES

1. Close #2 shut off valve, then close #1 shut-off valve.
2. Bleed pressure from the assembly by opening #2, #3, and #4 test cock.

CAUTION: Caps are spring loaded and should be removed carefully to avoid personal injury.

3. Unscrew cap using hex head provided.
4. Remove spring and poppet assembly from the body.

B. DISASSEMBLY — CHECK VALVE POPPET

CAUTION: Do not use pliers or other tools which may damage or scratch the plastic stem.

1. Holding the poppet assembly in one hand, remove screw and retaining washer.
2. Remove the seat disc.
3. All parts should be carefully inspected for any damage or excessive wear and thoroughly rinsed in clean water prior to reassembly. Replace worn parts as necessary.

ASSEMBLY — CHECK VALVE POPPET

1. Install new disc in poppet, secure disc with retaining washer and screw.

NOTE: Due to symmetry of the disc, the old disc may be turned over to obtain an effective seal.

D. ASSEMBLY — CHECK VALVE

1. Install the poppet assembly into the body.
2. Install the spring (heavy spring, larger diameter wire, goes into #1 check valve) onto the poppet.
3. Apply a thin coat of synthetic based lubricant on cap O-Ring.
4. Guide cap over spring and poppet stem and tighten cap.

E. RELIEF VALVE DISASSEMBLY

1. Remove cover bolts, cover and diaphragm.
2. Grasp the diaphragm plate and pull the assembly straight out of the body.
3. Holding the relief valve assembly in one hand, remove the screw and retaining washer.
4. Remove the seat disc.
5. Turn the assembly over, keeping the spring compressed by holding down on the diaphragm plate, remove the screw.
6. Remove the diaphragm plate, spring and bushing from the R.V. stem.
7. Remove the O-Ring from the R.V. stem.
8. All parts should be carefully inspected for any damage or excessive wear and thoroughly rinsed in clean water prior to reassembly. Replace worn parts as necessary.

F. ASSEMBLY — RELIEF VALVE

1. Apply a thin coat of synthetic base lubricant on O-Rings before installing.
2. Install O-Ring onto R.V. stem.
3. Slide bushing over R.V. stem and position spring onto bushing.
4. Position diaphragm plate and compress spring, install screw into R.V. stem.
5. Turn the assembly over and install seat disc, retaining washer and screw.
6. Install O-Ring onto bushing.
7. Slide complete assembly into the body.
8. Position diaphragm over flange, install cover and tighten bolts evenly.
9. Open #1 shut-off valve & bleed air out of the unit through #2, #3 and #4 test cocks; then open #2 shut-off valve.
10. Test complete assembly to ensure proper operation.

V. MAINTENANCE INSTRUCTIONS - 2-1/2" - 10"

A. DISASSEMBLY — CHECK VALVES

1. Close #2 shut off valve, then close #1 shut-off valve.
2. Bleed pressure from the assembly by opening #2, #3, and #4 test cock.
3. Remove cover bolts and cover.

NOTE: *The spring load on the cover will be removed when the cover bolts are backed off approximately 3/8".*

4. Remove the complete check assembly straight out of the valve body being careful not to damage the seat ring.
5. The check valve seat is threaded into the body and may be removed at this time if necessary (the seat is bolted into the body on the 10" unit).
6. To remove the seat disc, remove the retaining plate nut (on the 8" & 10" units remove the retaining

WARNING:

The check valve spring is held in compression by the stem nut on top. This nut should not be removed unless the spring requires replacement.

B. ASSEMBLY — CHECK VALVES

1. Install seat disc in holder and secure with retaining plate and retaining nut or bolts as applicable.

NOTE: *Due to the symmetry of the disc, the old disc may be turned over to obtain an effective seal.*

2. Install the check valve assembly into the body (assemble with the larger diameter spring into the first check valve).
3. Apply a thin coat of synthetic based lubricant on the cover O-Ring and place it into the groove around the lip of the check barrel. Being careful not to disturb O-Ring, install the cover and tighten the bolts evenly.

C. DISASSEMBLY — RELIEF VALVE

1. Remove cover bolts, cover and diaphragm.

NOTE: *On the 8" & 10" units the diaphragm is an integral part of the relief valve assembly.*

2. Grasp the diaphragm plate and pull the assembly straight out of the body.
3. Holding the relief valve assembly in one hand, remove the screw and retaining washer.
4. Remove the seat disc.
5. Turn the assembly over, keeping the spring compressed by holding down on the diaphragm plate, remove the screw/bolt.
6. Remove the diaphragm plate(s), spring and bushing from the R.V. stem.
7. Remove the O-Ring from the R.V. stem.
8. All parts should be carefully inspected for any damage or excessive wear and thoroughly rinsed in clean water prior to reassembly. Replace worn parts as necessary.

D. ASSEMBLY — RELIEF VALVE

1. Apply a thin coat of synthetic base lubricant on O-Rings before installing.
2. Install O-Ring onto R.V. stem.
3. Slide bushing over R.V. stem and position spring onto bushing.
4. Position diaphragm plate(s) and compress spring, install screw into R.V. stem.
5. Turn the assembly over and install seat disc, retaining washer and screw.
6. Install O-Ring onto bushing.
7. Slide complete assembly into the body testing for freedom of movement.
8. Position diaphragm over flange ensuring that the hole in the diaphragm for the sensing passage is in the correct position, install cover and tighten bolts evenly.
9. Open #1 shut-off valve & bleed air out of the unit through #2, #3 and #4 test cocks; then open #2 shut-off valve.
10. Test complete assembly to ensure proper operation.

VI. TESTING PROCEDURES

IT'S IMPORTANT THAT THE RPZ BE TESTED PERIODICALLY IN COMPLIANCE WITH LOCAL CODES, BUT AT LEAST ONCE A YEAR OR MORE, AS SERVICE CONDITIONS WARRANT.

EQUIPMENT REQUIRED

Reduced pressure backflow preventer test kit 40-200-TKU, or 40-200-TK5U.

TEST NO. 1:

NOTE: Test set-up is illustrated in Figure 3.

Procedure 1 for use with 40-200-TKU Test Kit only. See procedure 2 for 40-200-TK5U.

PURPOSE: TO TEST OPERATION OF THE PRESSURE DIFFERENTIAL RELIEF VALVE.

REQUIREMENT:

The pressure differential relief valve must operate to maintain the "zone" between the two check valves at a minimum of 2 PSI less than the supply pressure.

PROCEDURE:

1. Bleed water through all four test cocks to flush any foreign material.

NOTE: Open test cock #2 very slowly to avoid accidental dumping of the relief valve.

2. Connect the "high" side hose to test cock #2.

3. Connect the "low" side hose to test cock #3.

4. Open valves #1, #2, and #3.

5. Slowly open test cock #3 and bleed all air from gauge and hoses through the "vent" hose. With test cock #3 maintained in the open position, slowly open test cock #2 and bleed all air again through the "vent" hose. Close valve #3. Then close valve #2.

6. Close #2 shut-off valve.

7. Slowly open valve #3 until the differential gauge needle starts to drop.

NOTE: It is important that the differential gauge needle drops slowly. Maintain #3 at this position and observe the differential pressure reading at the moment the first discharge is noted from the relief valve.

8. Record this reading as the opening differential pressure of the relief valve and close valve #3.

TEST NO. 2:

PURPOSE: TO TEST CHECK VALVE #2 FOR TIGHTNESS AGAINST REVERSE FLOW.

REQUIREMENT:

The check valve shall permit no through leakage in a direction reverse to normal flow under all conditions of a pressure differential.

PROCEDURE:

1. Maintain the #2 shut-off valve in the closed position (from Test No. 1).

2. Loosely attach the "vent" hose to test cock #4.

3. Bleed all air from the "vent" hose by opening valve #2.

1. Close valve #2 and tighten hose connection to test cock #4. Then open test cock #4.

1. Loosen the "low" side hose at test cock #3 slightly and re-establish the normal reduced pressure within the zone. Then retighten hose.

1. Open valve #2. If the differential pressure remains steady then check valve #2 is reported as "OK". If the differential pressure falls until the relief valve opens then check valve #2 is recorded as "leaking" and Test No. 3 cannot be completed.

TEST NO. 3:

PURPOSE: TO TEST THE STATIC DIFFERENTIAL PRESSURE ACROSS CHECK VALVE #1.

REQUIREMENT:

The static differential pressure across check valve #1 must be a minimum of 3 PSI more than the opening differential pressure of the relief valve as recorded in Test No. 1.

PROCEDURE:

1. With the testing equipment installed as stated in Test No. 2, the static differential pressure across check valve #1 will be indicated on the gauge and should be recorded as such.

NOTE: Gauge needle should be steady and not falling.

RESTORE OPERATION:

2. Close all test cocks, open all needle-valves, open #2 shut-off valve and carefully remove all test equipment.

NOTE: Refer to Troubleshooting Guide in section III to resolve any problems incurred during field testing.

VI. TESTING PROCEDURES

FIGURE 3

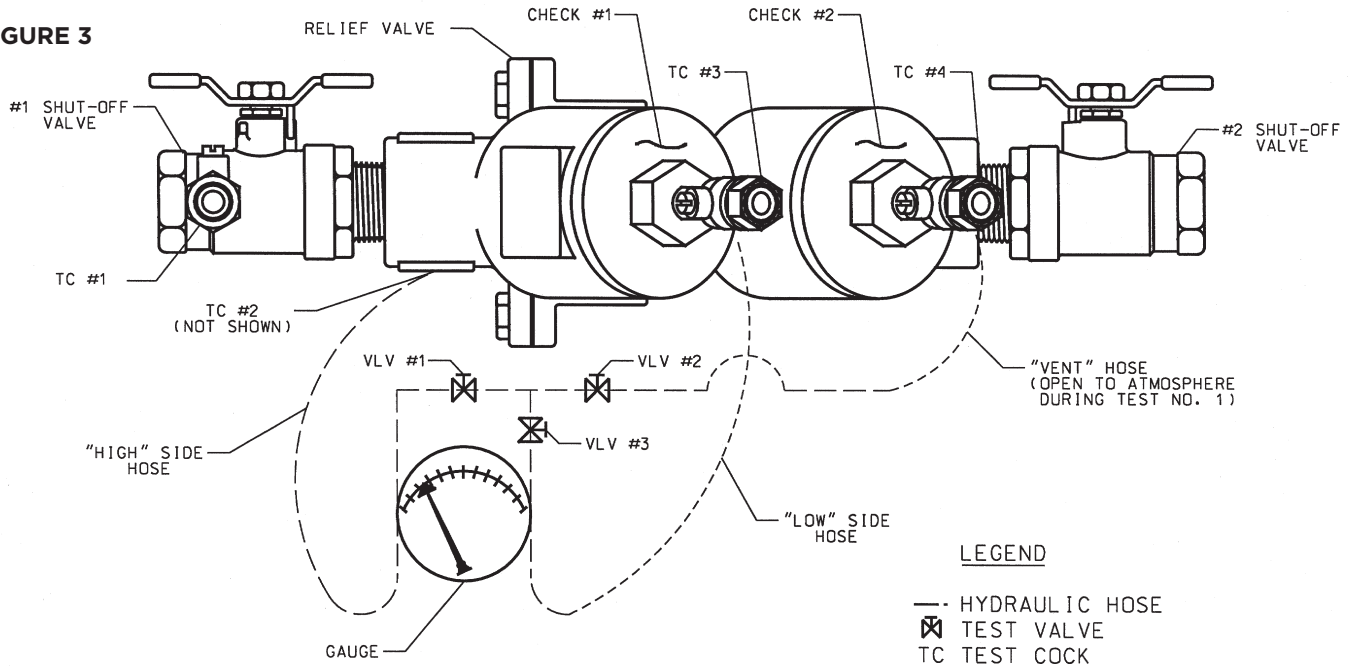
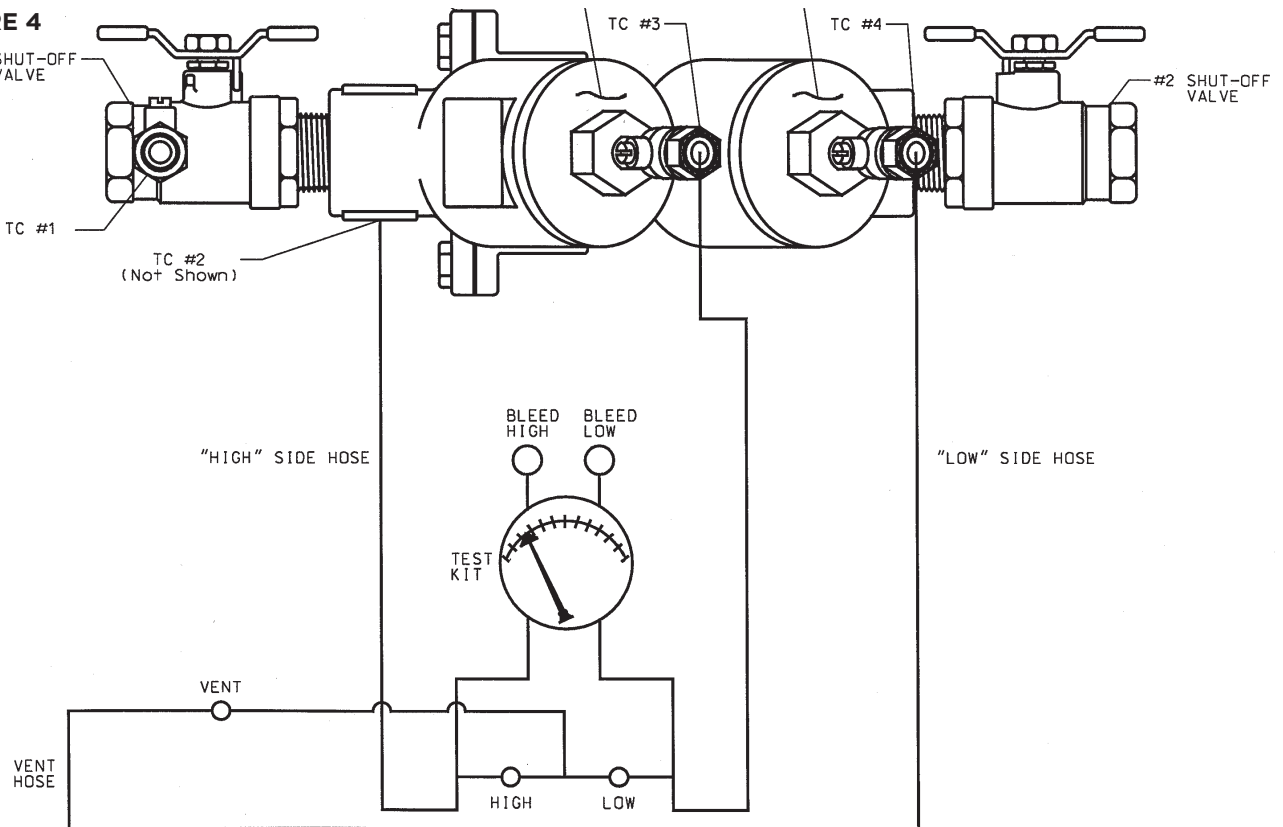

FIGURE 4



VI. TESTING PROCEDURES

PROCEDURE 2

TEST PROCEDURE USING 40-200-TK5 or 40-200-TKRC TEST KIT

NOTE: IT IS THE TESTER'S RESPONSIBILITY TO DETERMINE IF THIS PROCEDURE IS ACCEPTED BY LOCAL AUTHORITIES.

TEST SET UP

1. Obtain permission to shut off the water supply.
2. Determine the direction of flow.
3. Identify and install appropriate adapters in all 4 test cocks.
4. All test kit valves are closed.

TEST NO. 1

PURPOSE: DOES THE DIFFERENTIAL PRESSURE RELIEF VALVE OPERATE TO MAINTAIN THE "ZONE" BETWEEN THE TWO CHECK VALVES AT LEAST 2 PSI LESS THAN THE SUPPLY PRESSURE.

1. Open test cock 4 to establish flow through the RP. "Blow out" test cocks 1, 2 & 3.

Note: Open test cock 2 slowly to avoid accidental dumping of the relief valve. Close test cock 4.

2. Connect the red hose between test cock 2 and the high side (back, middle) connection on the test kit.
3. Connect the green hose between test cock 3 and the low side (back, right) connection on the test kit.
4. Slowly open test cock 3. Bleed the low side by opening the bleed low (top, right) valve.
5. Slowly open test cock 2. Bleed the high side by opening the bleed high (top, left) valve. Close the bleed high (top, left) valve.
6. After the gauge reaches full scale, close the bleed low (top, right) valve.
7. Close the No. 2 shutoff valve and observe the pressure drop across Check Valve 1. Should the pressure drop until the relief valve discharges continuously, check valve 1 is leaking and must be repaired before continuing.
8. Open the high (bottom, middle, red) valve.
9. Open the low (bottom, right, green) valve no more than one quarter (1/4) turn.
10. Watch the gauge drop slowly to the relief valve opening point - record the reading. (If the differential pressure does not drop to the relief valve opening point, close the high and low valves and go to step 12).
11. Close the high and low valves and go to test No. 2.
12. No. 2 shutoff valve may be leaking. Reopen and close No. 2 shutoff valve to attempt a better shutoff. Repeat steps 7 through 10. If the relief valve does not open, a by-pass hose is required. (Large leaks may require a garden hose).
13. Attach a hose (not supplied with Test Kit) to test cock 1. Bleed hose by opening test cock 1. Close test cock 1.
14. Connect the hose from test cock 1 to test cock 4.
15. Open test cock 1 to pressurize the hose.
16. Slowly open test cock 4. Repeat steps 8 through 10. If the relief valve does not open, the leaky No. 2 shutoff valve must be repaired.

TEST NO. 2

PURPOSE: IS CHECK VALVE 2 PRESSURE TIGHT AGAINST BACK PRESSURE.

NO BYPASS HOSE USED IN TEST 1.

1. Connect the black hose to vent (back, left) connection on the test kit.
2. Bleed vent hose by opening the high (bottom, middle, red) and vent (bottom, left, black) valves. Close the vent valve.
3. Attach the vent hose to test cock 4.
4. Open test cock 4.
5. Open the bleed low (top, right) valve allowing the gauge to reach full scale. Close the bleed low valve.
6. Open the vent (bottom, left, black) valve.
7. If the differential pressure stabilizes above the relief valve opening point check valve 2 is recorded as "tight". (Proceed to test No. 3). If the reading falls to the relief valve opening point, check valve 2 is recorded as "leaking" and Test No. 3 cannot be completed.

BYPASS HOSE USED IN TEST 1.

1. Leave the bypass hose connected between test cocks 1 and 4.
2. Leave test cocks 1 and 4 open.
3. Open the bleed low (top, right) valve allowing the gauge to reach full scale. Close the bleed low valve.
4. If the differential pressure stabilizes above the relief valve opening point, check valve 2 is recorded as "tight". (Proceed to Test No. 3). If the reading falls to the relief valve opening point, check valve 2 is recorded as "leaking" and Test No. 3 cannot be completed.

TEST NO. 3

IS THE STATIC PRESSURE DROP ACROSS CHECK VALVE 1 MAINTAINED AT LEAST 3 PSI ABOVE THE RELIEF VALVE OPENING POINT.

1. Open the bleed low (top, right) valve allowing the gauge to reach full scale. Close the bleed low valve.
2. Allow the gauge reading to stabilize. Record this reading as the static pressure drops across check valve 1.
3. Close all test cocks. Open the No. 2 shutoff valve.
4. Remove all test equipment. Drain test kit

PART NUMBER DIAGRAM - 1/4" - 2" BRONZE

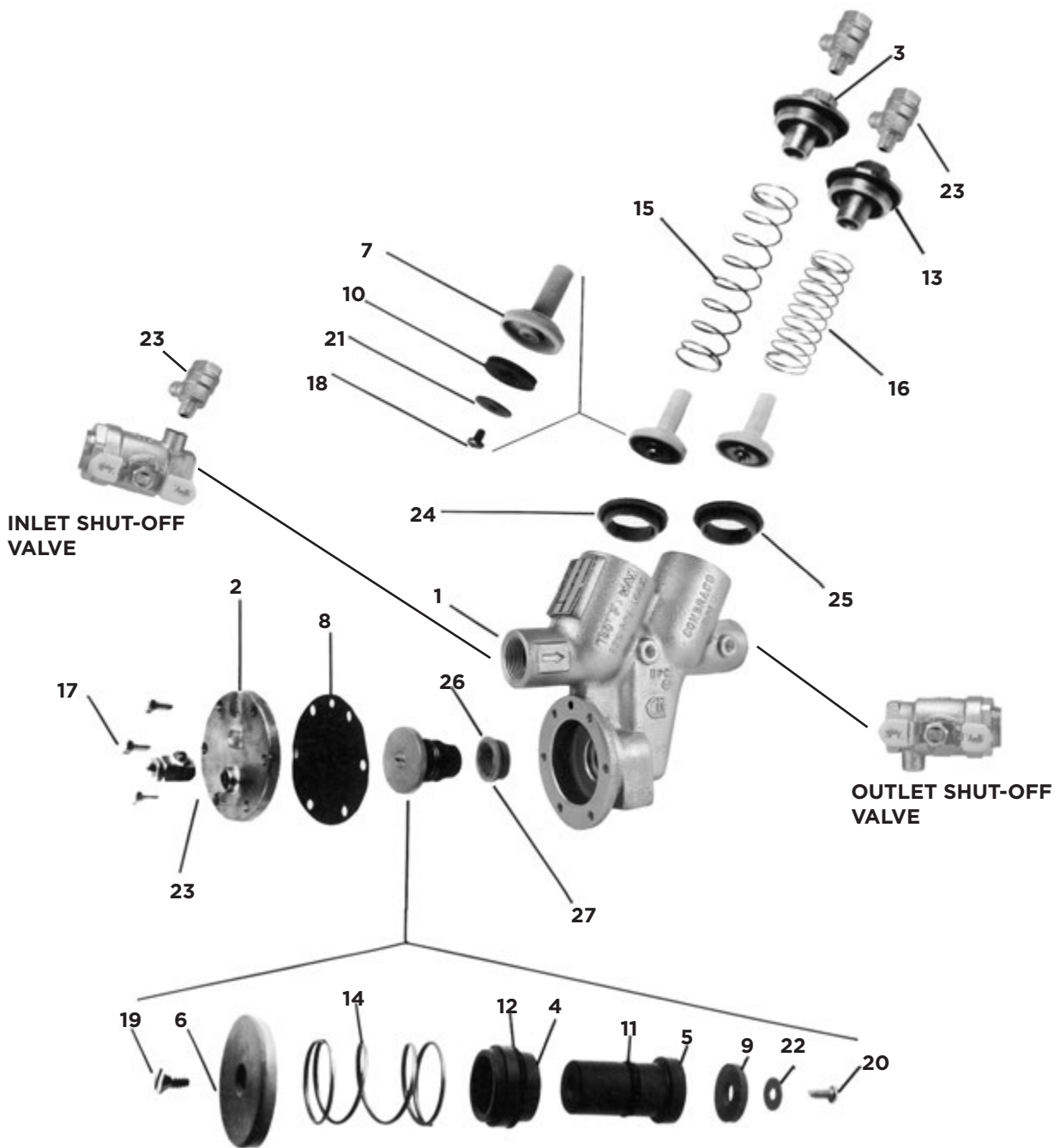

INLET AND OUTLET SHUT-OFF VALVES 40-20X-TX

SIZE	1/4"	3/8"	1/2"	3/4"	1"	1-1/4"	1-1/2"	2"
Inlet Shut-Off Valve (pictured)	7B80101	7B80201	7B80301	7B80401	7B80501	7B80699A	7B80799A	7B80899A
Inlet Shut-Off Valve w/Union			7B30301	7B30401	7B30501	7B30699A	7B30799A	7B30899A
Outlet Shut-Off Valve (pictured)	7B80131	7B80231	7B80331	7B80431	7B80531	7B80699B	7B80799B	7B80899B
Outlet Shut-Off Valve w/Union			7B30331	7B30431	7B30531	7B30699B	7B30799B	7B30899B
Replacement Handles for Shut-Off Valves	W858800	W858800	W858800	W858800	W859100	W891500	W891600	W891600

PARTS LIST - 1/4" - 2" BRONZE

ITEM NO	DESCRIPTION	QUANTITY	PART NO		
			1/4", 3/8", 1/2"	3/4" & 1"	1-1/4", 1-1/2", 2"
1	Body	1	Consult Factory	Consult Factory	Consult Factory
2	RV Cover	1	F301705	F298205	F298505
3	Cap	2	F323105	F310805	F311505
4	RV Bushing	1	I450715	I424015	I425715
5	RV Stem	1	G329600	G321200	G321300
6	Diaphragm Plate	1	E222200	D250600	D251600
7	Poppet	2	K340900	K336200	K336700
8	RV Diaphragm	1	D263200	D250500	D251500
9	RV Seat Disc	1	D263100	D282900	D251400
10	Check Seat Disc	2	D263000	D250300	D250800
11	Stem O-Ring	1	D262800	D250200	D251300
12	Bushing O-Ring	1	D262900	D250100	D251200
13	Check Cap O-Ring	2	D204600	D250000	D251000
14	RV Spring	1	A179500	A169800	A170200
15	1st Check Spring	1	A179700	A169900	A170300
16	2nd Check Spring	1	A179400	A170000	A170100
17	Hex Head Bolt	6(*4)(**7)	B179300	B175100	B175400
18	Screw	2	B183700	B175000	B175000
19	Screw	1	B174900	B174900	B175300
20	Screw	1	B183700	B174800	B175300
21	Retaining Washer	2	E222300	D249900	D250900
22	Retaining Washer	1	E222400	D249800	D249900
23	Test Cock	4	7829001	7829001	7829101
24	Check Seat	2	L515200	L486400	L486600
25	Check O-Ring	2	D308600	D227400	D256500
26	RV Seat	1	L515300	L486300	L486700
27	RV O-Ring	1	D308700	D216800	D227400

*1/4", 3/8" & 1/2" SIZES ONLY

**1-1/4", 1-1/2" & 2" SIZES ONLY

REPAIR KITS***

KIT	PARTS INCLUDED	PART NO		
		1/4", 3/8", 1/2"	3/4" & 1"	1-1/4", 1-1/2", 2"
Major Repair Kit	4, 5, 6, 7 (2), 8, 9, 10 (2), 11, 12, 13 (2), 14, 18 (2), 19, 20, 21 (2), 22, 24 (2), 25 (2), 26, 27	40003A1	40004A1	40007A1
Check Valve Repair Kit	7, 10, 13, 18, 21, 24, 25	40007A2	40007A2	40007A2
Relief Valve Repair Kit	4, 5, 6, 8, 9, 11, 12, 14, 19, 20, 22, 26, 27	40003A3	40004A3	40007A3
Rubber Repair Kit	8, 9, 10 (2), 11, 12, 13 (2), 25 (2), 27	40003A4	40004A4	40007A4
Replaceable Seat Kit	24 (2), 25 (2), 26, 27	40003A7	40004A7	40007A7
Air Gap Drain	-	40200XA	40200X1	40200X1
Seat Removal Tool	-	40000SRT	40000SRT	40000SRT

*** For repair kits without replaceable seat components, replace part number suffix designation "A" with "O". Example: Major Repair Kit part number 40004O1

PART NUMBER DIAGRAM - 1/4" - 2" STAINLESS STEEL

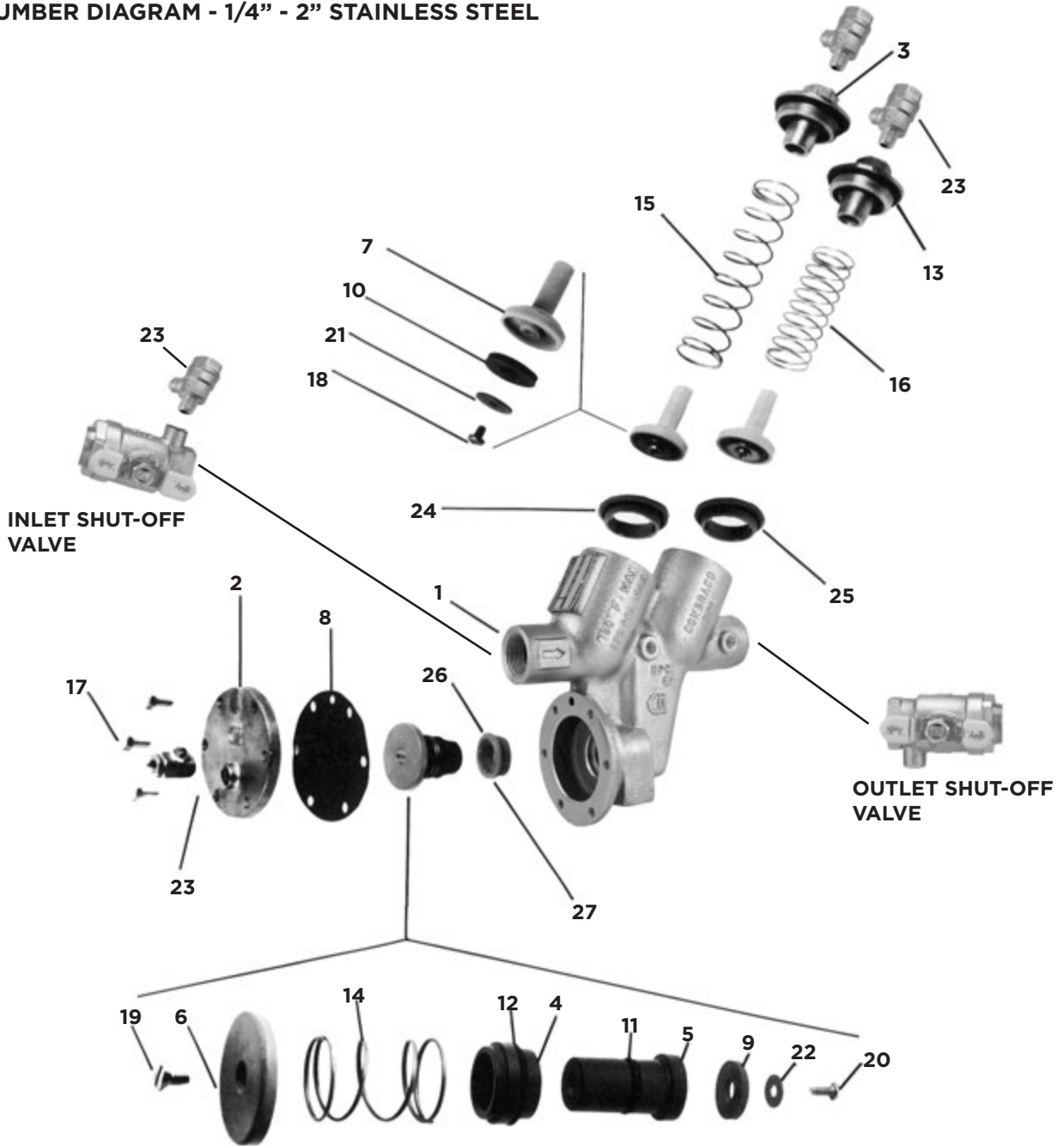

INLET AND OUTLET SHUT-OFF VALVES
40-20X-T2S

SIZE	1/4"	3/8"	1/2"	3/4"	1"
Inlet Shut-Off Valve	7H80101	7H80201	7H80301	7H80401	7H80501
Outlet Shut-Off Valve	7H80131	7H80231	7H80331	7H80431	7H80531
Replacement Handles for Shut-Off Valves	W858800	W858800	W858800	W858800	H269300

PARTS LIST - 1/4" - 2" STAINLESS STEEL

ITEM NO	DESCRIPTION	QUANTITY	PART NO	
			1/4", 3/8", 1/2"	3/4" & 1"
1	Body	1	Consult Factory	Consult Factory
2	RV Cover	1	F305605	F304805
3	Cap	2	F323205	F323305
4	RV Bushing	1	I514915	I510515
5	RV Stem	1	G329600	G321200
6	Diaphragm Plate	1	E222200	D250600
7	Poppet	2	K340900	K336200
8	RV Diaphragm	1	D308800	D304700
9	RV Seat Disc	1	D263100	D282900
10	Check Seat Disc	2	D263000	D250300
11	Stem O-Ring	1	D308400	D305100
12	Bushing O-Ring	1	D308500	D304400
13	Check Cap O-Ring	2	D308300	D305200
14	RV Spring	1	A179500	A169800
15	1st Check Spring	1	A179700	A169900
16	2nd Check Spring	1	A179400	A170000
17	Hex Head Bolt	6(*4)(**7)	B179300	B175100
18	Screw	2	B183700	B174800
19	Screw	1	B174900	B174900
20	Screw	1	B183700	B175000
21	Retaining Washer	2	E222300	D249900
22	Retaining Washer	1	E222400	D249800
23	Test Cock	4	7893001	7893001
24	Check Seat	2	L515200	L486400
25	Check O-Ring	2	D308600	D304600
26	RV Seat	1	L515300	L486300
27	RV O-Ring	1	D308700	D304500
	O-Ring Lubricant	1	I901600	I901600

*3/4", 1" SIZES ONLY

REPAIR KITS

KIT	PARTS INCLUDED	PART NO	
		1/4", 3/8", 1/2"	3/4" & 1"
Major Repair Kit	4, 5, 6, 7 (2), 8, 9, 10 (2), 11, 12, 13 (2), 14, 18 (2), 19, 20, 21 (2), 22, 24 (2), 25 (2), 26, 27	40003A1S	40004A1S
Check Valve Repair Kit	7, 10, 13, 18, 21, 24, 25	40003A2S	40004A2S
Relief Valve Repair Kit	4, 5, 6, 8, 9, 11, 12, 14, 19, 20, 22, 26, 27	40003A3S	40004A3S
Rubber Repair Kit	8, 9, 10 (2), 11, 12, 13 (2), 25 (2), 27	40003A4S	40004A4S
Replaceable Seat Kit	24 (2), 25 (2), 26, 27	40003A7S	40004A7S
Air Gap Drain	-	40200XA	40200X1
Seat Removal Tool	-	40000SRT	40000SRT

PART NUMBER DIAGRAM - 2-1/2", 3", 4", 6" RPZ

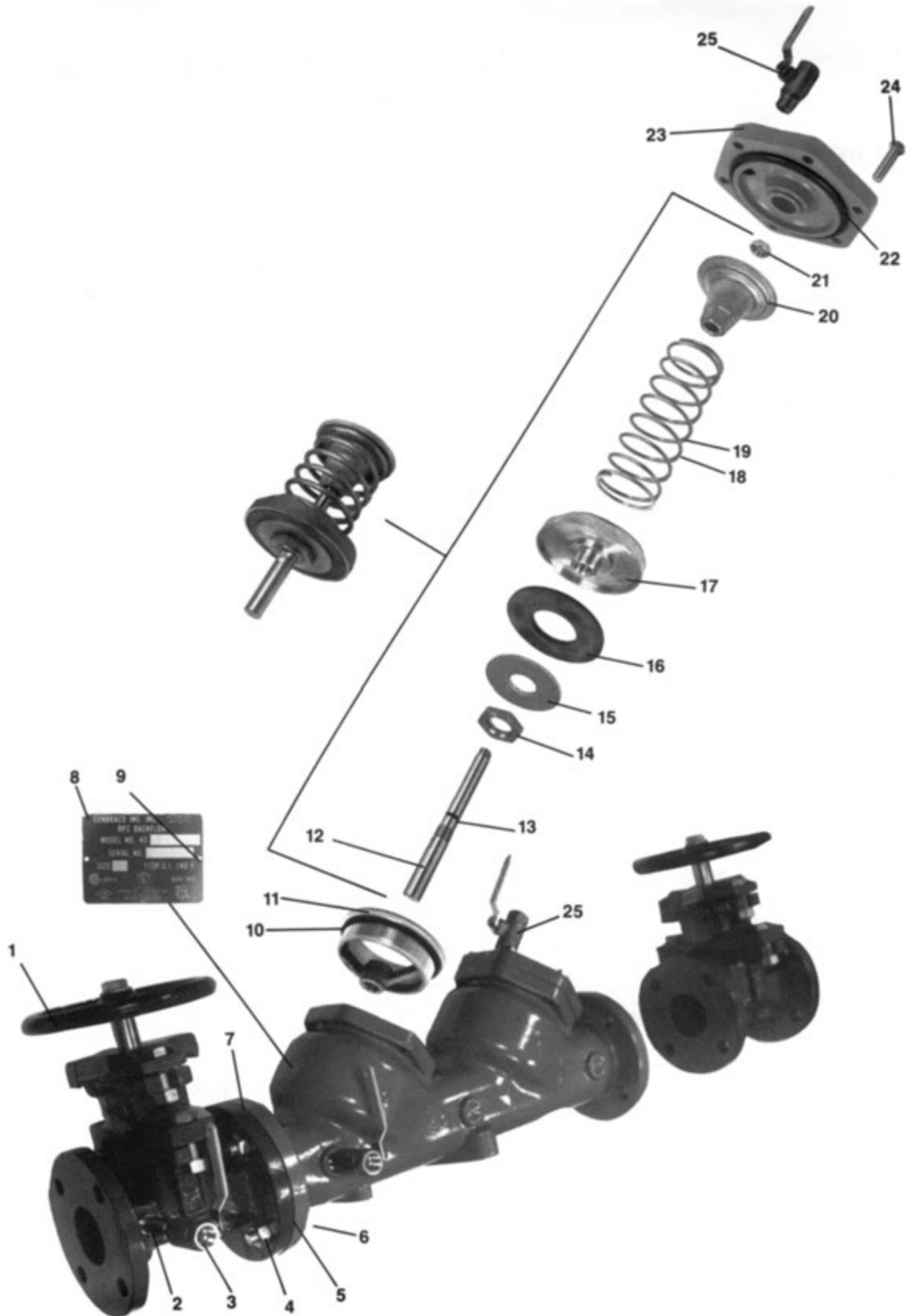

PARTS LIST - 2-1/2", 3", 4", 6" RPZ

ITEM NO	DESCRIPTION	QUANTITY	PART NO			
			2-1/2"	3"	4"	6"
1	Shut-Off Valve (OS&Y)	2	W678900	W679000	W682400	W682500
1	Shut-Off Valve (NRS)	2	W678500	W678600	W674300	W674400
2	Brass Nipple	1	K340600	K340600	K340600	K341240
3	Test Cock	1	7010301	7010301	7010301	7010401
4	Flange Nut	*	C169100	C169100	C169100	C175900
5	Ring Gasket	2	D258300	D258400	D258200	D257900
6	Flange Bolt	*	B180400	B180400	B182800	B182900
7	Body	1	Q452919	Q453219	Q453819	
8	Nameplate	1	I440600	I440600	I440600	
9	Drive Screw	2	I261300	I261300	I261300	I261300
10	C.V. Seat O-Ring	2	D256700	D256700	D257300	D257600
11	C.V. Seat	2	L463705	L463705	L464005	L464405
12	C.V. Stem	2	G323906	G323906	G324206	G324600
13	C.V. Stem O-Ring	2	D256100	D256100	D256100	D257600
14	Retainer Nut	2	C175600	C175600	C175600	C176000
15	Retainer Washer	2	E219900	E219900	E220400	E220500
16	C.V. Seat Disc	2	D256000	D256000	D257200	D257500
17	Seat Disc Holder	2	F300005	F300005	F300105	F300205
18	1st Check Spring	1	A174000	A174000	A174300	A174500
19	2nd Check Spring	1	A174100	A-174100	A174400	A174600
20	Spring Retainer	2	E219805	E219805	E220205	E220305
21	Jam Nut	2	C158905	C158905	C158905	C170600
22	Cap O-Ring	2	D256600	D256600	D257400	D257700
23	C.V. Cap	2	Q453019	Q453019	Q453319	Q453719
24	Cap Bolt	12	B179700	B179700	B180100	B180000
25	Test Cock	3	7080301	7080301	7080301	7080401

*2-1/2" & 3" QTY = 8 / 4" QTY = 16 / 6" QTY = 24

PART NUMBER DIAGRAM - 8", 10" RPZ

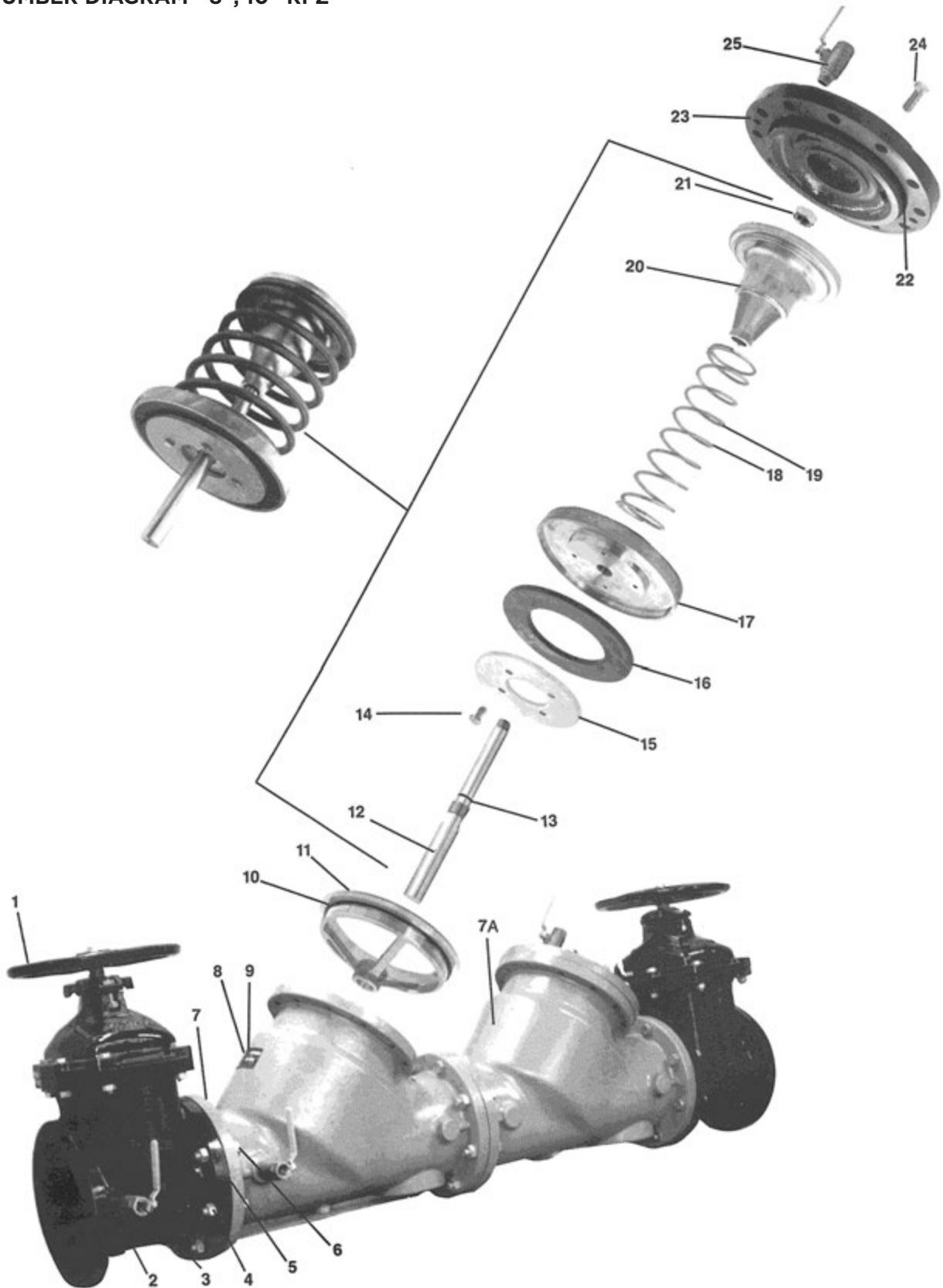

PARTS LIST - 8", 10" RPZ

ITEM NO	DESCRIPTION	QUANTITY	PART NO	
			8"	10"
1	Shut-Off Valve (OS&Y)	2	W682600	W685900
1	Shut-Off Valve (NRS)	2	W682700	W685800
2	Brass Nipple	1	K341200	K341200
3	Test Cock	1	7010401	7010401
4	Flange Nut	*	C175900	C179300
5	Ring Gasket	3	D259000	D265300
6	Flange Bolt	**	B185700	B185800
6A	Stud	2	N/A	B203600
7	Body	1	Q454319	Q457219
7A	Body	1	Q459319	Q459519
8	Nameplate	1	I440600	I440600
9	Drive Screw	2	I261300	I261300
10	C.V. Seat O-Ring	2	D258900	D258800
11	C.V. Seat	2	L465305	L475905
12	C.V. Stem	2	G327300	G330500
13	C.V. Stem O-Ring	2	D258700	D258700
14	Retainer Nut/Bolt	***	C175400	C175400
15	Retainer Washer	2	E220800	E222900
16	C.V. Seat Disc	2	D258600	D264900
17	Seat Disc Holder	2	F300805	F301905
18	1st Check Spring	1	A174700	A177800
19	2nd Check Spring	1	A174800	A177900
20	Spring Retainer	2	E220705	E222805
21	Jam Nut	2	*C176305	*C176305
22	Cap O-Ring	2	D258800	D265100
23	C.V. Cap	2	Q454519	Q457419
24	Cap Bolt	****	B169000	B188100
25	Test Cock	3	7080401	7080401
	Seat Bolt	12	N/A	B184900

*8" QUANTITY = 24 / 10" QUANTITY = 38
 **8" QTY = QUANTITY / 10" QUANTITY = 34
 ***8" & 10" QUANTITY = 8
 ****8" & 10" QUANTITY = 24

PART NUMBER DIAGRAM - 2-1/2" - 6" RELIEF VALVES

2-1/2" - 6" Relief Valve

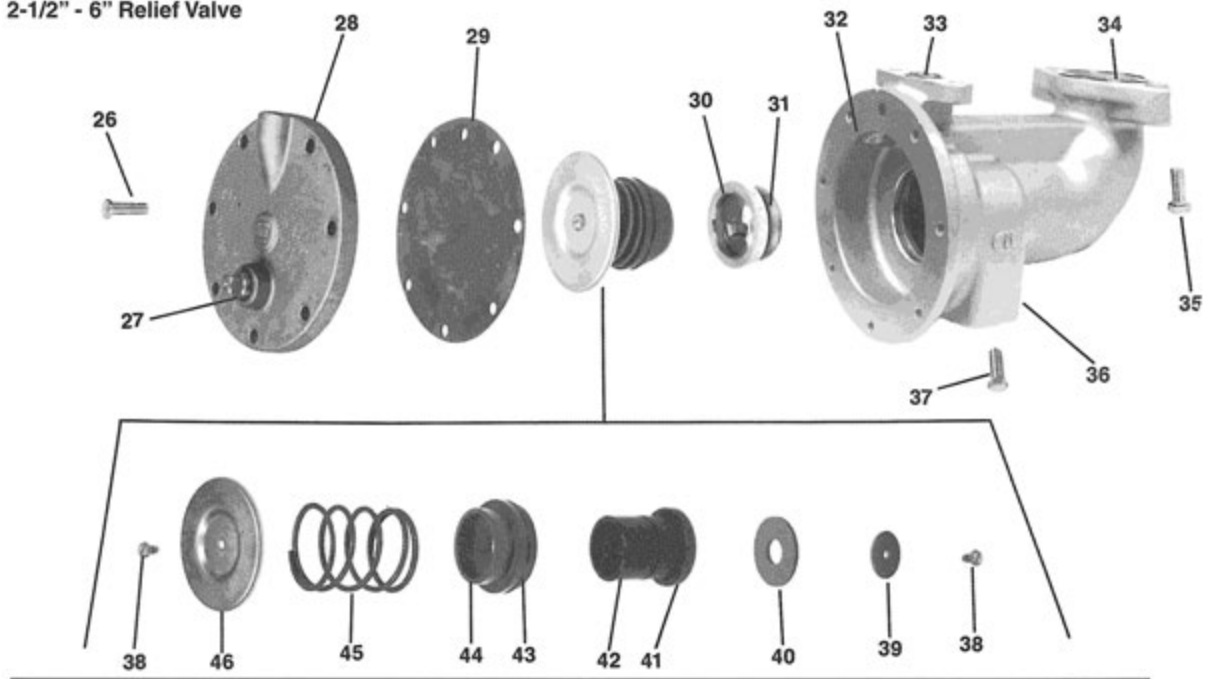

8" & 10" Relief Valve

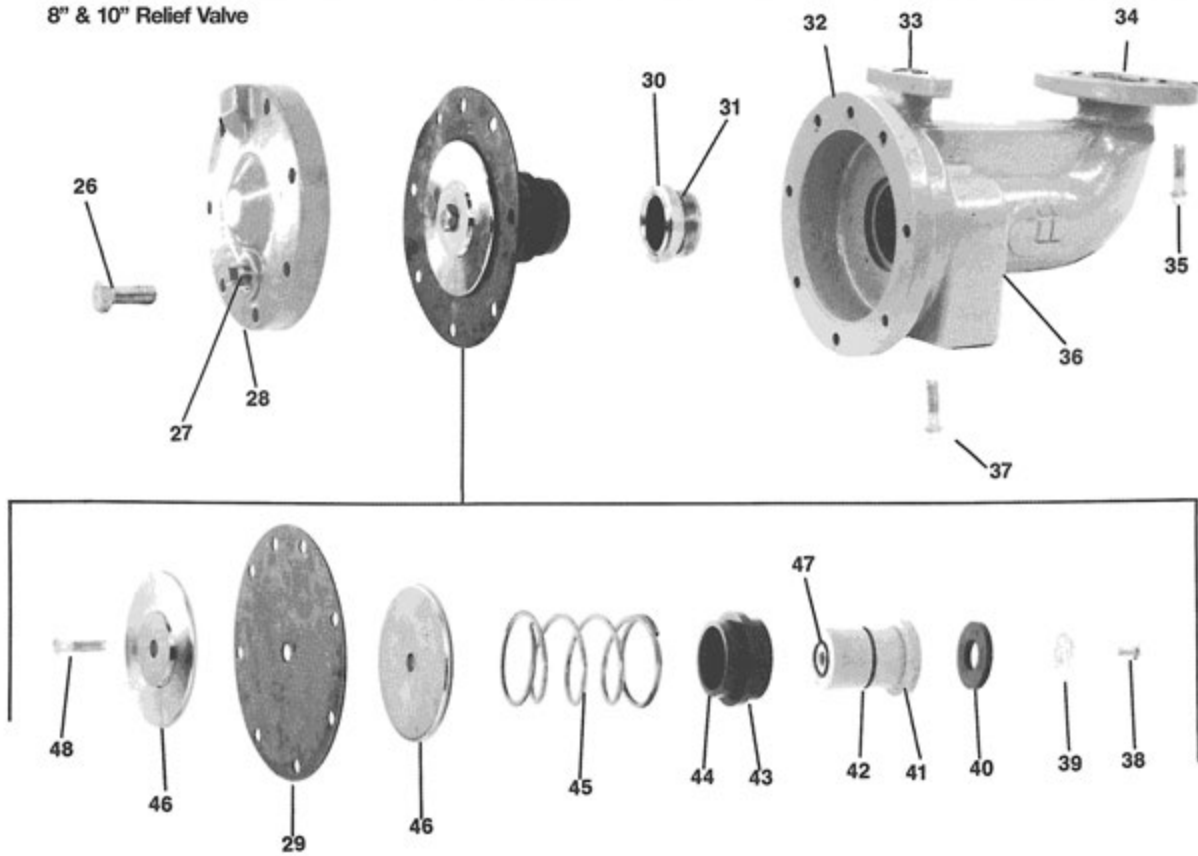

PARTS LIST - 2-1/2" - 6" RELIEF VALVES

ITEM NO	DESCRIPTION	2-1/2" - 6"		8" - 10"	
		QUANTITY	PART NO	QUANTITY	PART NO
26	Relief Valve Cover Bolt	7	B179600	7	B170300
27	1/2 NPT Plug	1	K300800	N/A	N/A
27	3/4 NPT Plug	N/A	N/A	1	K301000
28	Relief Valve Cover	1	Q453105	1	Q454219
29	Relief Valve Diaphragm	1	D256400	1	D259100
30	Relief Valve Seat Ring	1	L463805	1	L465105
31	Relief Valve Seat Ring	1	D256800	1	D2593-00
32	Relief Valve Body	1	Q453505	1	Q454119
33	Small Relief Valve O-Ring	1	D257000	1	D218600
34	Large Relief Valve O-Ring	1	D257100	1	D230400
35	Relief Valve Flange Bolt	2	B180000	4	B166900
36	1/4 NPT Plug	1	K301900	1	K301900
37	Relief Valve Flange Bolt	2	B179200	2	B166900
38	Pan Head Screw	2	B175300	1	B185600
39	Relief Valve Seat Washer	1	E220000	1	E221000
40	Relief Valve Seat Disc	1	D256300	1	D259500
41	Relief Valve Stem	1	G324000	1	G327405
42	Relief Valve Stem O-Ring	1	D256500	1	D259400
43	Relief Valve Bushing O-Ring	1	D256200	1	D259200
44	Relief Valve Bushing	1	L463915	1	L465215
45	Relief Valve Spring	1	A174200	1	A174900
46	Diaphragm Plate	1	E220100	2	E220905
47	Stem Face O-Ring	N/A	N/A	1	D210600
48	Diaphragm Bolt	N/A	N/A	1	B180000

REPAIR KITS

KIT	PARTS INCLUDED	PART NO				
		2-1/2", 3"	4"	6"	8"	10"
1st Check Valve Repair Kit	12, 13, 14, 15, 16, 17, 18, 20, 21, 22	4000901	4000A01	4000C01	4000E01	4000G01
2nd Check Valve Repair Kit	12, 13, 14, 15, 16, 17, 19, 20, 21, 22	4000902	4000A02	4000C02	4000E02	4000G02
Seat Repair Kit	10, 11, 22	4000903	4000A03	4000C03	4000E03	4000G03
Check Rubber Repair Kit (2 of each part)	10, 13, 16, 22	4000904	4000A04	4000C04	4000E04	4000G04
Relief Valve Repair Kit	29, 30, 31, 33, 34, 38, 39, 40, 41, 42, 43, 44, 45, 46, (47, 48)*	4000905	4000A05	4000C05	4000E05	4000G05
Air Gap Drain	29, 31, 33, 34, 40, 42, 43, (47)*	4000906	4000A06	4000C06	4000E06	4000G06

*8" & 10" Only

PART NUMBER DIAGRAM - 3" - 4" RPDA

NOTES

- USE P/N W-7062-00 FOR METER IN CUBIC FEET REGISTER.
- USE P/N W-7094-00 FOR METER IN GALLONS REGISTER.
- N/S - NOT SHOWN

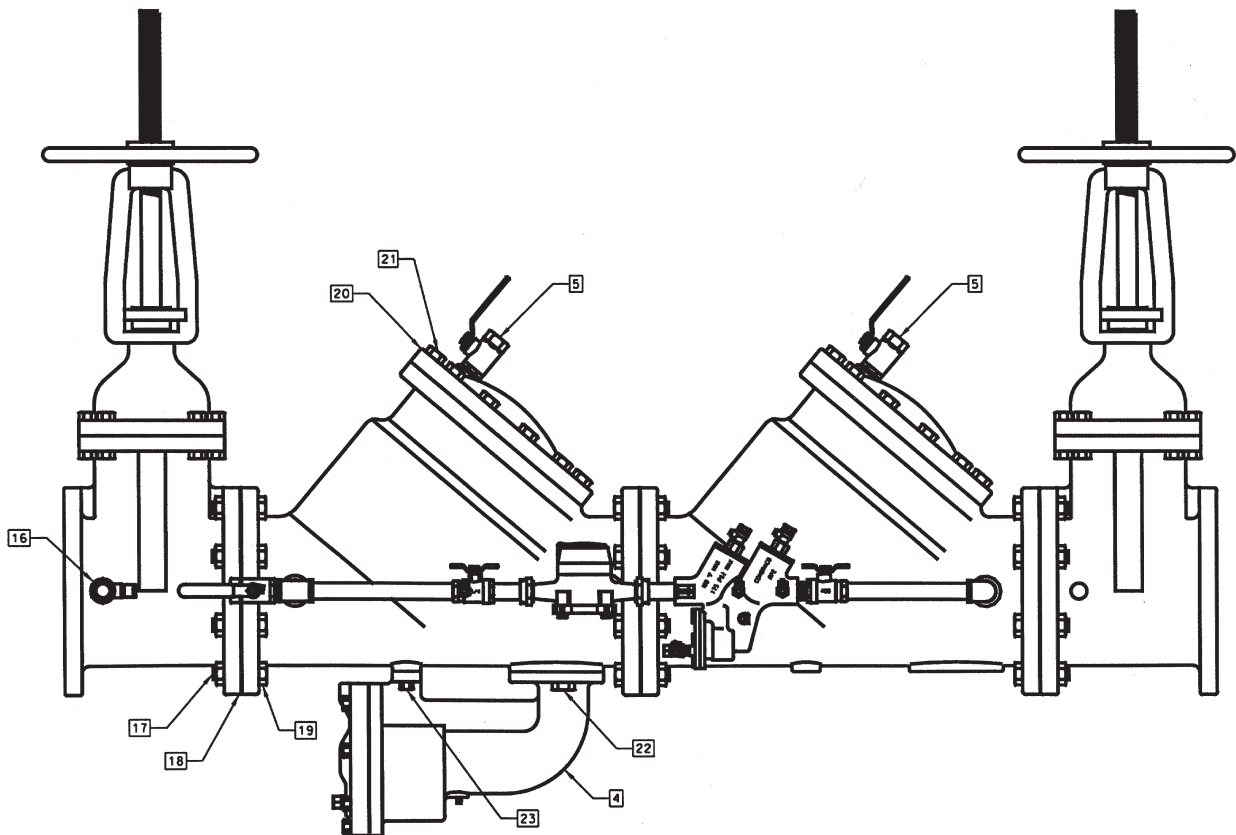
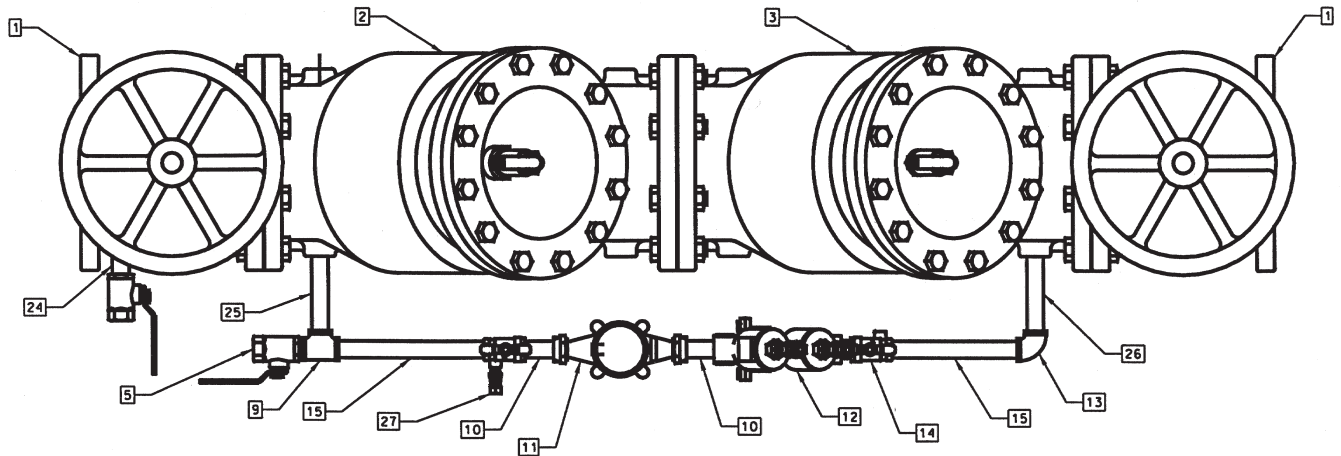

RPDA BYPASS ASSEMBLY KITS

- 3" RPDA w/meter in cubic feet 40700BPC
- 3" RPDA w/meter in gallons 40700BPE
- 4" RPDA w/meter in cubic feet 4070ABPC
- 4"RPDA w/meter in gallons 4070ABPE

PARTS LIST - 3" - 4" RPDA

ITEM NO	DESCRIPTION	QUANTITY	PART NO	
			3"	4"
1	Gate Valve (OS&Y)	2	W679000	W682400
2	RPDA Body	1	Q493419	Q480719
3	Relief Valve Assembly	1	W672905	W672905
4	Test Cock	3	7080301	7080301
N/S	1st Check Poppet Assembly	1	W671705	W673005
N/S	2nd Check Poppet Assembly	1	W728905	W710005
7	Bypass Shut-Off Valve	1	7B10401	7B10401
8	Tee, Reducing	1	K350600	K350600
9	Coupling, Water Meter	2	K350500	K350500
10	Water Meter in Cubic Feet	1	W706200	W706200
10	Water Meter in Gallons	1	W709400	W709400
11	3/4" RPZ	1	W739005	W739005
12	Elbow, Street	*	K350200	K350200
13	By-Pass Shut-Off Valve	1	7B10431	7B10431
14	Nipple, Close	4	K337000	K337000
15	Test Cock	1	7010301	7010301
N/S	Flange Nut	**	C143800	C143800
17	Flange Gasket	2	D258400	D258200
18	Flange Bolt	**	B180400	B182800
19	Cap	2	Q453019	Q453319
20	Cap Bolt	12	B179700	B180100
21	Relief Valve Flange Bolt (Large)	2	B180000	B180000
22	Relief Valve Flange Bolt (Small)	2	B179200	B179200
23	Nipple	1	K340600	K340600
24	Test Cock	1	7825701	7825701
N/S	Nipple, 3/4" x 4-1/2" (Large)	1	K360500	N/A
N/S	Elbow, 3/4" - 90°	1	K350100	N/A
N/S	Cap O-Ring	2	D256600	D257400
N/S	Seat O-Ring	2	D256700	D257300
N/S	Relief Valve O-Ring (Small)	1	D257000	D257000
N/S	Relief Valve O-Ring (Large)	1	D257100	D257100
N/S	Nameplate	1	I499100	I499100
N/S	Nameplate Tack	2	I529400	I529400
N/S	Instruction Booklet	1	I503600	I503600
N/S	Check Valve Seat	2	L463705	L464005

* 3" QTY = 3 / 4" QTY = 1

** 3" QTY = 8 / 4" QTY = 16

PART NUMBER DIAGRAM - 6" - 10" RPDA

NOTES

- USE P/N W-7062-00 FOR METER IN CUBIC FEET REGISTER.
- USE P/N W-7094-00 FOR METER IN GALLONS REGISTER.
- N/S - NOT SHOWN

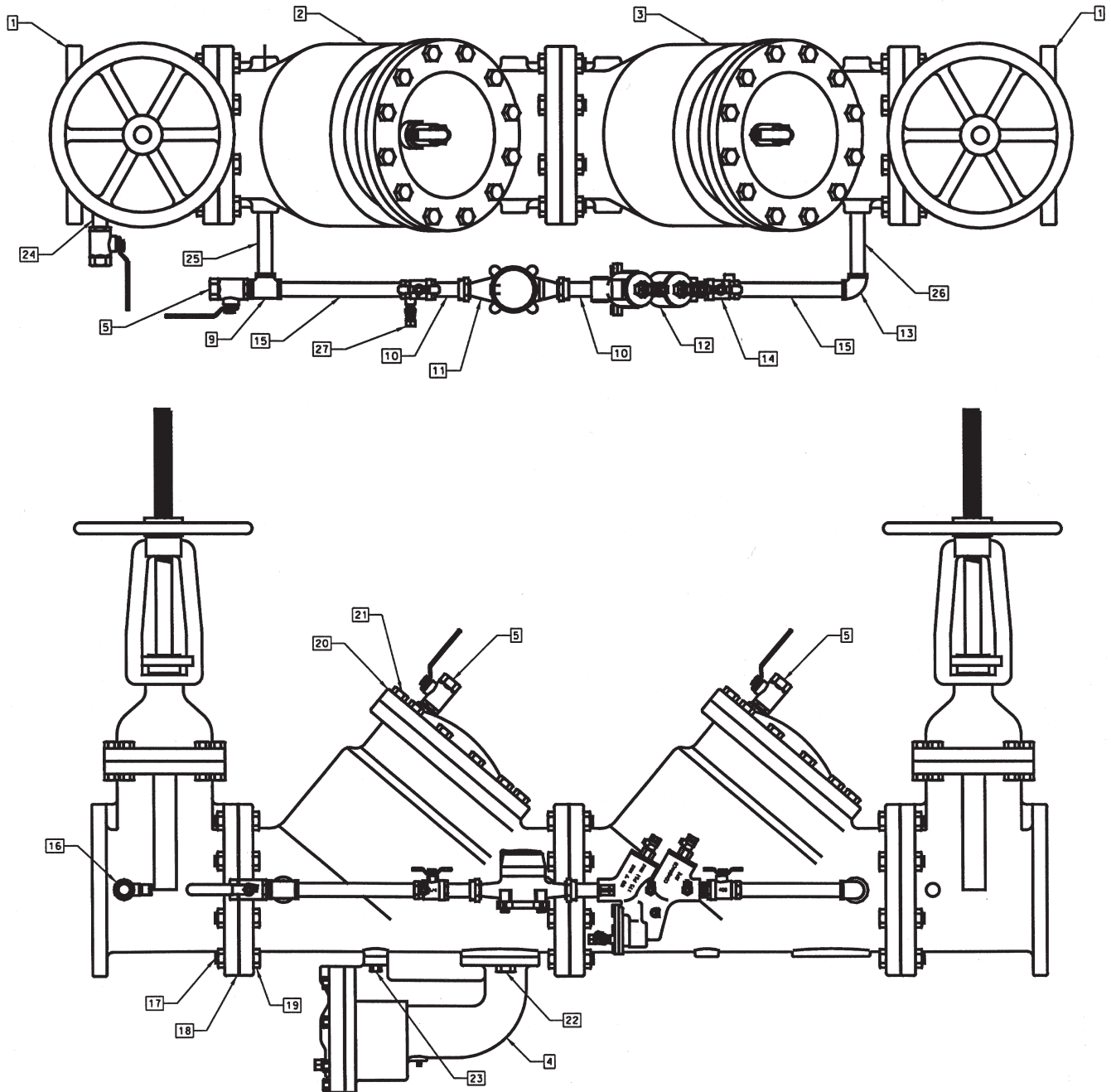

RPDA BYPASS ASSEMBLY KITS

- | | |
|----------------------------------|----------|
| • 6" RPDA w/meter in cubic feet | 4070CBPC |
| • 6" RPDA w/meter in gallons | 4070CBPE |
| • 8" RPDA w/meter in cubic feet | 4070EBPC |
| • 8"RPDA w/meter in gallons | 4070EBPE |
| • 10" RPDA w/meter in cubic feet | 4070GBPC |
| • 10"RPDA w/meter in gallons | 4070GBPE |

PARTS LIST - 6" - 10" RPDA

ITEM NO	DESCRIPTION	QUANTITY	PART NO		
			6"	8"	10"
1	Gate Valve (OS&Y)	2	W682500	W682600	W685900
2	Body (1st Check)	1	Q453819	Q454319	Q457219
3	Body (2nd Check)	1	Q459119	Q459319	Q459519
4	Relief Valve Assembly	1	W672905	W674805	W674805
5	Test Cock	3	7080401	7080401	7080401
N/S	1st Check Poppet Assembly	1	W674105	W674505	W685605
N/S	2nd Check Poppet Assembly	1	W720605	W720705	W724905
8	By-Pass Shut-Off Valve	1	7B10401	7B10401	7B10401
9	Tee, 3/4" NPT	1	K351100	K351100	K351100
10	Coupling, Water Meter	2	K350500	K350500	K350500
11	Water Meter in Cubic Feet	1	W706200	W706200	W706200
11	Water Meter in Gallons	1	W709400	W709400	W709400
12	3/4" RPZ	1	W739005	W739005	W739005
13	Elbow, 3/4" NPT	1	K350100	K350100	K350100
14	By-Pass Shut-Off Valve	1	7B80431	7B80431	7B80431
15	Nipple, 3/4" NPT	2	K350900	K352700	K356000
16	Test Cock	1	7010401	7010401	7010401
17	Flange Nut	*	C175900	C175900	C179300
18	Flange Gasket	3	D257900	D259000	D265300
19	Flange Bolt	**	B182900	B185700	B185800
20	Cap	2	Q453719	Q454519	Q457419
21	Cap Bolt	***	B180000	B169000	B188100
22	Relief Valve Flange Bolt (Large)	****	B180000	B166900	B166900
23	Relief Valve Flange Bolt (Small)	2	B179200	B166900	B166900
24	Nipple, 3/4" NPT	1	K341200	K341200	
25	Nipple, 3/4" x 5-1/2" (Large)	1	K350900	K350900	K350900
26	Nipple, 3/4" NPT	1	K350900	K350900	K355900
27	Test Cock	1	7825701	7825701	7825701
N/S	Elbow, 3/4" - 90°	1	K350100	K350100	K350100
N/S	Cap O-Ring	2	D257700	D258800	D265100
N/S	Seat O-Ring	2	D257600	D258900	D258800
N/S	Relief Valve O-Ring (Small)	1	D257000	D218600	
N/S	Relief Valve O-Ring (Large.)	1	D257100	D230400	
N/S	Nameplate	1	I499100	I499100	I499100
N/S	Nameplate Tack	2	I529400	I529400	I529400
N/S	Instruction Booklet	1	I503600	I503600	I503600
N/S	Check Valve Seat	2	L464405	L465305	L475905
N/S	Stud	2	N/A	N/A	B203600
N/S	Seat Bolt	12	N/A	N/A	B184900

* 6" & 8" QTY = 24 / 10" QTY = 38
 ** 6" & 8" QTY = 24 / 10" QTY = 34
 *** 6" QTY = 12 / 8" & 10" QTY = 24
 **** 6" QTY = 2 / 8" & 10" QTY = 4

TEST KITS

DESCRIPTION

Backflow Preventer Test Kits are compact, lightweight and portable testing devices. They come equipped with a gauge, hoses and all required adapter fittings. Also included is a flexible or adjustable strap for hanging the gauge, laminated test procedures and a molded plastic carrying case with foam inserts.

DIFFERENTIAL PRESSURE GAUGE TEST KIT

40-200-TKU

This is a three valve test kit used for testing all DCV, RPZ, PVB & SVB backflow preventers.

The gauge is a differential pressure type with a dual scale of 0-15 psid/0-100kPa differential pressure range with a $\pm 2\%$ accuracy (full scale).

DIFFERENTIAL PRESSURE GAUGE TEST KIT

40-200-TK5U

This five valve kit is used for testing all DCV, RPZ, PVB & SVB backflow preventers.

The five valve test kit is similar to the three valve kit except it has an additional two valves that make it possible to bleed lines without disconnecting hoses.

MODEL	APPLICATION	WT./100 (LB)
40-200-TKU	ALL DCV, RPZ, PVB & SVB	780
40-200-TK5U	ALL DCV, RPZ, PVB & SVB	650

40-200-TKU



40-200-TK5U



"Apollo"®

PHONE: (704) 841-6000

FAX: (704) 841-6020

Regional Management List
now available online at:

<http://conbra.co/rmlist>

ES1595 IOM BFM4S00 rev.b 8/17

Customer Service (704) 841-6000
www.apollovalves.com

