



SERVICE PARTS LIST

BULLETIN NO.
54-07-9800

SPECIFY CATALOG NO. AND SERIAL NO. WHEN ORDERING PARTS			REVISED BULLETIN	DATE
LASER DISTANCE METERS				Nov. 2016
CATALOG NO.	48-22-9801	STARTING SERIAL NO.	WIRING INSTRUCTION	
		H82A		
CATALOG NO.	48-22-9802	STARTING SERIAL NO.		
		H83A		
CATALOG NO.	48-22-9803	STARTING SERIAL NO.		
		H84A		

EXAMPLE:

00 0

Component Parts (Small #)
Are Included When Ordering
The Assembly (Large #).

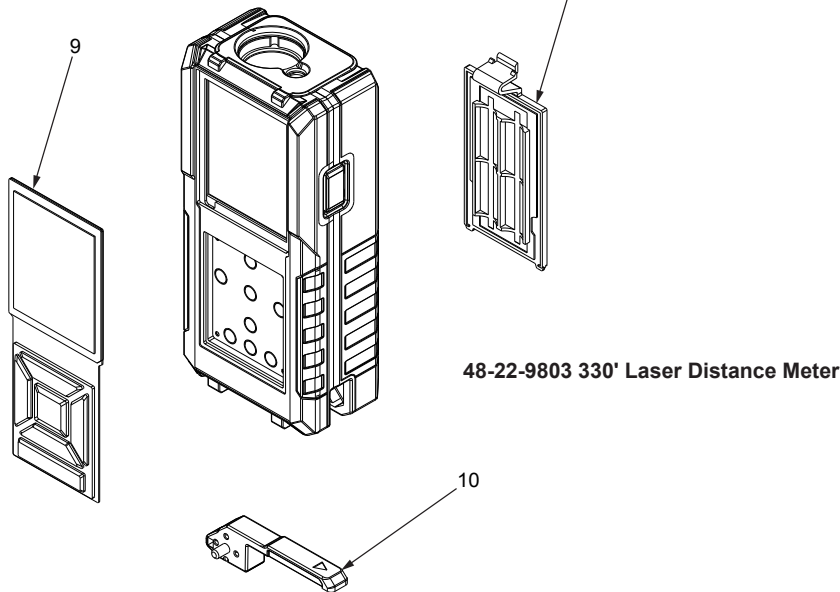
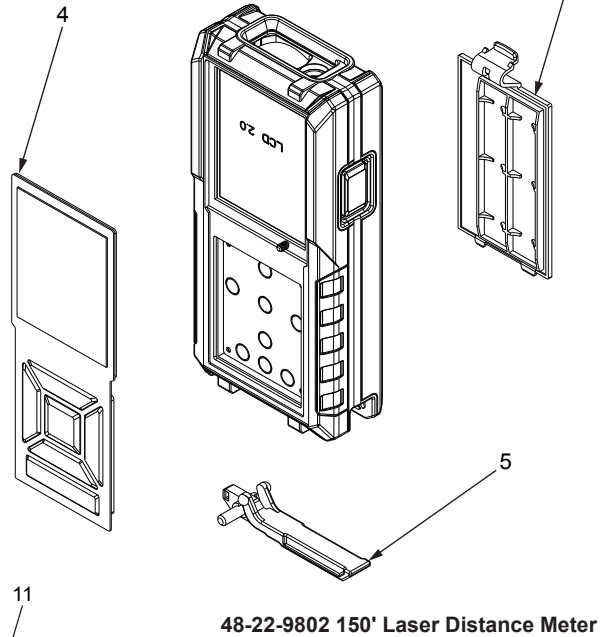
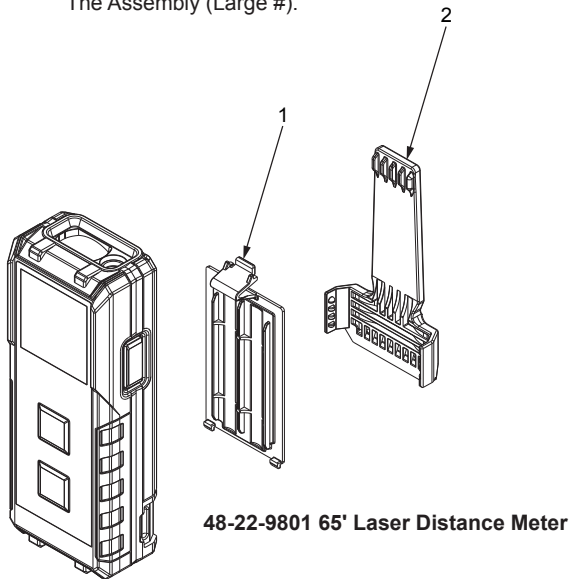

FIG.	PART NO.	DESCRIPTION OF PART	NO. REQ.
1	31-21-0220	Battery Door	(1)
2	42-70-0285	Belt Clip	(1)
3	12-20-0517	Service Nameplate (Not Shown)	(1)
4	45-03-0170	Screen w/ Buttons	(1)
5	44-10-0011	Lever	(1)
6	31-21-0225	Battery Door	(1)
7	12-20-0518	Service Nameplate (Not Shown)	(1)
8	42-55-0039	Fabric Case (Not Shown)	(1)
9	45-03-0180	Screen w/ Buttons	(1)
10	44-10-0013	Lever	(1)
11	31-21-0230	Battery Door	(1)

FIG.	PART NO.	DESCRIPTION OF PART	NO. REQ.
12	12-20-0519	Service Nameplate (Not Shown)	(1)
13	42-55-0041	Fabric Case (Not Shown)	(1)

FIG. NOTES

3, 7, 12 A clean, dry surface is essential for proper performance for any adhesive system. The area intended for application of any adhesive label or nameplate must be prepared by cleaning with isopropyl alcohol. The solvent is to be applied with a clean, lint free applicator and the surface allowed to dry before applying the label or nameplate.