



ATX™ FELED SERIES NONMETALLIC LED LUMINAIRES

FEATURES

- Easy to retrofit in same mounting footprint as Appleton's FE series nonmetallic fluorescent luminaires.
- Full range of lumen outputs, with light distribution equivalent to Appleton's FE series fluorescent luminaires.
- Corrosion-resistant fiberglass reinforced polyester body and hinged polycarbonate lens.
- High impact resistance housing (20 Joules – IK10) from -30 °C to +55 °C (-22 °F to +131 °F) ambient temperature and wind profile for use in extreme offshore and onshore environments.
- 60,000+ hour LED life at +55 °C (+131 °F) ambient for years of maintenance free operation.
- Lightweight design, hinged cover with captive screws, and terminal block wiring for easy installation and maintenance.
- Contemporary, low profile design suitable for tight spaces.
- Standard screw-type terminal block can accept 1.5 to 6 mm² wire.
- Field replaceable LED driver.
- Industry-leading thermal management for safe, reliable operation over wide temperature range.
- Universal, high efficiency, drivers cover voltage requirements for 120-277 Vac, 170-300 Vdc, 50/60 Hz +/- 10%.
- High power factor electronic driver (>0.95).
- Standard 6KV surge suppression.
- M20 plug or M25 plug provided.
- Latch assembly and elastomer gasket seals against water and dust ingress, IP66.
- Easily accessed for maintenance using Hex or Allen key or straight blade screwdriver.
- Central opening with unique patented release system to prevent damage.

- Can be horizontally or vertically mounted.
- Available in 3 hour emergency version, including built-in monthly self-test. Test results through multi-colored LED.
- Positive safety switch disconnects power to LED's and driver to allow maintenance in hazardous locations (emergency).
- Ex e battery with plug-in connector.
- Available in 5000K and 4000K Color Temperatures
- Meets Photobiological Requirement for Risk Group 0 (RG0).

SUITABLE LOCATIONS

- For use in locations where:
 - Hazardous areas are designated as Zone 1, and 2, 21 and 22
 - A high degree of corrosion resistance is required
 - Protection against dirt, water and moisture is necessary
- Typical applications include:
 - Oil refineries
 - Petrochemical facilities
 - Food processing plants
 - Waste and water treatment plants
 - Underground tunnels
 - General manufacturing facilities

STANDARD MATERIALS

- Housing: fiberglass reinforced polyester
- Lens: polycarbonate
- Diffuser: polycarbonate
- Gasket: elastomer
- Internal reflector: highly reflective white polycarbonate (standard versions) or powder coated aluminum (emergency versions)
- Mounting accessories available in different materials such as gray painted aluminum, zinc plated steel, galvanized steel or 316 stainless steel

OPTIONS

- 3 Hours Emergency / Battery Back-Up available ⓘ;
 - Add suffix -E to the end of the catalog number. Example: FELED5CBDSADE

ATEX/IECEX CERTIFICATIONS AND COMPLIANCES

- **Certification Type: FELED30**
 - Gas: Zones 1 and 2
 - Conforming to ATEX 2014/34/EU: II 2 G
 - Type of Protection: Ex eb mb op is IIC Gb
 - Temperature Class: T4
 - Dust: Zones 21 and 22
 - Conforming to ATEX 2014/34/EU: II 2 D
 - Type of Protection: Ex op is tb IIIC Db
 - Surface Temperature: +60 °C to +75 °C (+140 °F to +167 °F)
- Ambient Temperature: -30 °C up to +55 °C (-22 °F up to +131 °F)
- EU Declaration of Conformity: 50318
- ATEX Certificate: INERIS 18 ATEX 0042X
- IECEx Certificate: IECEx INE 18.0039X
- **Certification Type: FELED (emergency)**
 - Gas: Zones 1 and 2
 - Conforming to ATEX 2014/34/EU: II 2 G
 - Type of Protection: Ex db eb mb IIC Gb
 - Temperature Class: T6
 - Dust: Zones 21 and 22
 - Conforming to ATEX 2014/34/EU: II 2 D
 - Type of Protection: Ex tb IIIC Db
 - Surface Temperature: +63 °C to +73 °C (+145 °F to +163 °F)
- Ambient Temperature: -20 °C up to +50 °C (-4 °F up to 122 °F)
- EU Declaration of Conformity: 50317
- ATEX Certificate: LCIE 16 ATEX 3048X
- IECEx Certificate: IECEx LCIE 16.0038X
- **Standard and Emergency**
 - Index of Protection according EN/IEC 60529: IP66
 - Impact Resistance (shock): IK10
 - Photobiological Safety, IEC 62778 and IEC 62471: RG0 at 0.25m mounting height

ⓘ Available for 5K lumen model only.

APPLETON™

For product information:
www.masteringled.com
1.800.621.1506

EMERSON™

CONSIDER IT SOLVED™

ATX™ FELED SERIES NONMETALLIC LED LUMINAIRES

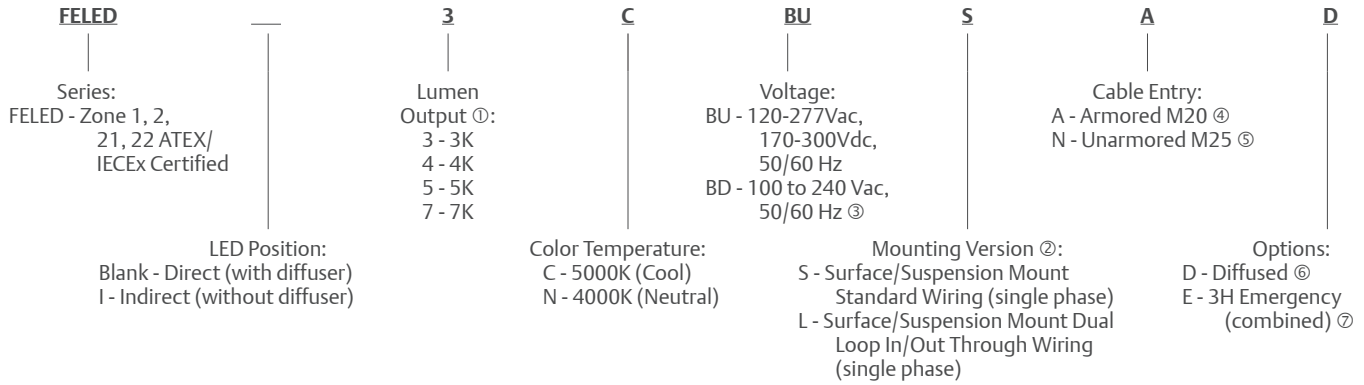

- ① All values displayed reflect typical values.
- ② Standard and Loop In/Out cable entries provide 3 entries; 1 at one and 2 at the other end of the housing.
- ③ BD voltage for emergency model only
- ④ Must order armored cable glands separately. M20 entries are with brass earth continuity plate for armored cable.
- ⑤ Cable glands provided in luminaires with unarmored hub entries.
- ⑥ Diffuser required for direct, not included with indirect.
- ⑦ Available for 5K lumen model only.

Product Specifications

	FELED3BU/ FELEDI3BU				FELED4BU/ FELEDI4BU				FELED5BU/ FELEDI5BU				FELED7BU/ FELEDI7BU			
	SA	SN	LA	LN	SA	SN	LA	LN	SA	SN	LA	LN	SA	SN	LA	LN
Line Current Amps	0.14A at 230Vac				0.195A at 230Vac				0.244A at 230Vac				0.333A at 230Vac			
Input Power	31 watts				44 watts				50 watts				75 watts			
Power Factor	>0.96				>0.96				>0.98				>0.97			
Correlated Color Temperature (CCT)	5000K		4000K		5000K		4000K		5000K		4000K		5000K		4000K	
LED Position	Direct	Indirect	Direct	Indirect	Direct	Indirect	Direct	Indirect	Direct	Indirect	Direct	Indirect	Direct	Indirect	Direct	Indirect
Lumen Output	3,058	1,886	2,512	1,616	4,196	2,617	3,428	2,111	5,290	3,260	4,380	2,613	7,181	4,200	5,878	3,458
Efficacy (Lumens per watt)	99	61	81	52	95	59	78	48	106	65	88	52	96	56	78	46
Color Rendering Index (CRI)	70+		80+		70+		80+		70+		80+		70+		80+	
Luminaire Length	0.785 m (2.58 ft)								1.39 m (4.56 ft)							
Lifetime (L70B10)	60,000+ hours															

LED Status for Emergency Version

Color	Indication	Function
Green	LED Blinking	Mains voltage available – Battery charging
	LED Continuous	Mains voltage available – Battery connected and loaded
Green and Red	LED Blinking Alternately (2s)	Mains voltage available – Battery in repair mode
Red	LED Blinking	Mains voltage available – No battery connected OR defective
	LED Continuous	Mains voltage NOT available – Light unit powered by batteries (emergency mode)
	LED Flashing	Mains voltage NOT available – Battery low (emergency mode completed)
Yellow (Orange) and another color	LED Blinking Alternately	Mains voltage available – Last automatic or manual operational check has been unsuccessful
None (Off)	No Light Emitted	Mains voltage NOT available – Battery completely empty

Self-Test : In 3 month intervals batteries are automatically discharged and recharged once.

Emergency Light Duration

Version	Battery Capacity	Duration	Light Output
5K	7 Ah – 6V	3 hours	25%