

SUITABLE FOR USE WITH OPTIONAL STANDBY SYSTEMS IN ACCORDANCE WITH ARTICLE 702 OF THE NATIONAL ELECTRICAL CODE®, ANSI/NFPA 70.

RATINGS: 225A MAXIMUM - SEE MAIN BREAKER RATING IF USED.
BACK-FED BREAKER REQUIRES HOLD-DOWN KIT ECMBR2.
120/240 V~; 60 HZ, 1Ø 3W ; 2Ø8Y/120 V~; 60 HZ, 1Ø 3W
SECTION 'A' IS RATED 125A MAX.

FOR INSTALLATION BY A QUALIFIED PERSON IN ACCORDANCE WITH ALL LOCAL ELECTRICAL CODES AND/OR THE NATIONAL ELECTRICAL CODE ®.

SUITABLE FOR USE AS SERVICE EQUIPMENT WHEN MAIN BREAKER IS INSTALLED. WHEN USED AS SERVICE EQUIPMENT, APPLY "SERVICE DISCONNECT" LABEL TO FRONT NEXT TO MAIN BREAKER HANDLE.

WHEN USED AS SERVICE EQUIPMENT, UNUSED NEUTRAL BAR TERMINALS MAY BE USED TO TERMINATE EQUIPMENT GROUNDING WIRES IN THE COMBINATIONS INDICATED FOR EQUIPMENT GROUND BAR TERMINALS.

TO BOND NEUTRAL TO ENCLOSURE: (1) REMOVE SCREW SECURING BOND STRAP. (2) INSERT ROUND END OF BOND STRAP INTO LARGE HOLE OF NEUTRAL IN LINE WITH BOND STRAP MOUNTING HOLE. (3) REASSEMBLE BOND STRAP TO ENCLOSURE WITH SCREW PROVIDED. TIGHTEN TO 25 LB-IN. (4) TIGHTEN CONNECTOR SET SCREW ON ROUND END OF BOND STRAP TO 45 LB-IN. WITH NEUTRAL BONDED, LEFT BAR BECOMES SPLIT NEUTRAL.

TO RESET BREAKERS WITH TRIPPED HANDLE POSITION BETWEEN "ON" AND "OFF", MOVE HANDLE TO "OFF" THEN TO "ON".

REMOVE TWISTOUTS FROM TRIM ONLY WHERE BREAKERS WILL BE INSTALLED. ALL OPENINGS MUST BE FILLED WITH BREAKERS OR FILLER PLATES. USE TWO QF3 FILLER PLATES TO FILL 150-225A MAIN BREAKER OPENING.

Siemens Industry, Inc. Norcross, Georgia U.S.A.

J2

4099338 Rev.B

IMPORTANT: DO NOT ALLOW PETROLEUM BASED (HYDROCARBON) SPRAYS, CHEMICALS, SOLVENTS OR ANY PAINT TO CONTACT INTERIOR COMPONENTS. PETROLEUM BASED CHEMICALS CAN CAUSE DEGRADATION OF ELECTRICAL INSULATING MATERIALS.

⚠ DANGER

**Hazardous Voltage.
Will cause death, serious injury
or substantial property damage.**

Turn off power supplying this
equipment before working inside.



⚠ PELIGRO

**Voltaje peligroso. Causará la
muerte, lesiones graves o daño
substantial a la propiedad.**

Desconecte el suministro de energía a este
equipo antes de trabajar en su interior.

SHORT CIRCUIT CURRENT RATING

THIS PANELBOARD HAS A MAXIMUM SHORT CIRCUIT CURRENT RATING OF 22,000 AMPS RMS SYMMETRICAL, 120/240V~. THE ACTUAL RATING IS DEPENDENT ON THE BRANCH BREAKERS INSTALLED IN THIS PANELBOARD AND THE MAIN/FEEDER BREAKER, IF ANY, INSTALLED AHEAD OF THIS PANELBOARD. THE CORRECT MAIN BREAKER/FEEDER/MAIN BREAKER/PANELBOARD MAIN BREAKER/BRANCH BREAKER SERIES COMBINATIONS TO BE USED ARE LISTED IN THE TABULATION BELOW. ANY CIRCUIT BREAKER INSTALLED, REPLACED, OR ADDED IN THIS PANELBOARD MUST BE MANUFACTURED BY SIEMENS AND MUST BE OF THE CORRECT TYPE AS INDICATED IN THE TABULATION BELOW. USE OF OTHER CIRCUIT BREAKERS IN THIS EQUIPMENT WILL VOID THE WARRANTY.

MAIN BREAKER	FEEDER/MAIN BREAKER	PANELBOARD MAIN†	BRANCH BREAKER	THEN THE MAX. SHORT CIRCUIT CURRENT RATING IN RMS SYMMETRICAL AMPS, 120/240 V~ IS
WHEN THE MAIN PROTECTING THE SYSTEM IS A	AND THE BREAKER PROTECTING THIS PANELBOARD IS A SIEMENS TYPE	AND THE INSTALLED MAIN BREAKER IN THIS PANELBOARD IS A SIEMENS TYPE	AND THE BRANCH BREAKERS INSTALLED ARE SIEMENS TYPE	
NONE USED	QN, QNR	NONE USED EQ8693, EQ8695, EQ8696 OR QP	QP QT, QPH, HQP, QPF, QPHF, QPF, QE, QEH, QAF, QAFH, QNR, QNRH, HQNR	10,000
NONE USED OR SIEMENS BREAKER TYPES FD6(-A), FXD6(-A), HFD6, HFXD6, JXD2(-A), JD6(-A), JXD6(-A), HJD6(-A), HJXD6(-A), LD6(-A), LXD6(-A), HLD6(-A), HLD6(-A), MD6, MXD6, HMD6, HMXD6, NDX6, NXD6, HND6, HNXD6, PD6, PDX6, HPD6, HFXD6, RD6, RXD6, HRD6, HRXD6, OR CLASS J, T, R OR L FUSES	NONE USED OR QPMH	EQ8693, EQ8695, EQ8696 OR QPH	QP, QT, QPH, HQP, QPF, QPHF, QE, QEH, QAF, QAFH, QNR, QNRH, HQNR	22,000
NONE USED	QNH, QNRH	NONE USED, EQ8693, EQ8695, EQ8696	QPH, QPHF, QEH, QAFH, QNRH	
NONE USED OR SIEMENS BREAKER TYPES FD6(-A), FXD6(-A), HFD6, HFXD6, JXD2(-A), JD6(-A), JXD6(-A), HJD6(-A), HJXD6(-A), LD6(-A), LXD6(-A), HLD6(-A), HLD6(-A), MD6, MXD6, HMD6, HMXD6, NDX6, NXD6, HND6, HNXD6, PD6, PDX6, HPD6, HFXD6, RD6, RXD6, HRD6, HRXD6, OR CLASS J, T, R OR L FUSES	QPPH, QJH2	NONE USED		
	NONE USED	NONE USED		

† THIS PANELBOARD IS A MAIN LUG DEVICE THAT MAY BE CONVERTED TO MAIN BREAKER WITH THE ADDITION OF FIELD INSTALLED MAIN BREAKER KIT OR A MAIN BREAKER DEVICE THAT MAY BE CONVERTED TO MAIN LUG WITH THE ADDITION OF MAIN LUGS. SEE ACCESSORY TABLE FOR CATALOG NUMBERS OF APPROPRIATE KITS.

THIS LOAD CENTER IS INVERTIBLE FOR BOTTOM FEED APPLICATIONS.

USE COPPER OR ALUMINUM 60°/75°C WIRE
SEE BREAKER MARKINGS FOR WIRE SIZE AND TORQUE REQUIREMENTS.

EQUIPMENT GROUND BAR

TERMINALS ARE SUITABLE FOR THE FOLLOWING WIRE COMBINATIONS:

SMALL TERMINALS: ONE 14 TO 6 AWG CU; ONE 12 TO 6 AWG AL; TWO 14 AWG CU; TWO 12 AWG CU; TWO 12 AWG AL SOLID WIRES.

LARGE TERMINALS: ONE 14 TO 2 AWG CU; ONE 12 TO 2 AWG AL; TWO OR THREE 14 AWG CU; TWO OR THREE 12 AWG CU OR AL; TWO 10 AWG CU; TWO OR THREE 10 AWG AL; THREE 10 AWG CU SOLID WHEN TORQUED TO 50 LB-IN; THREE 10 AWG CU STRANDED.

ACCESSORIES

DESCRIPTION	CATALOG NO.
DOOR LOCK	ECQFL2
FILLER PLATE, 1"	QF3
BREAKER HOLD-DOWN	ECMBR2
GROUND BAR KITS	USE "ECLX" SERIES
GENERATOR TRANSFER SWITCH	GENTFRSWTCH

TERMINALS	WIRE	TORQUE
A, B	300 kcmil-4 AWG	275 LB-IN
N	300 kcmil-4 AWG	250 LB-IN
G	2/0 - 6 AWG	90 LB-IN
NEUTRAL AND EQPT GROUND BAR		
SMALL TERMINALS	10 - 14 AWG	20 LB-IN
	8 AWG	25 LB-IN
	6 AWG	35 LB-IN
LARGE TERMINALS	10 - 14 AWG	35 LB-IN
	8 AWG	40 LB-IN
	1/0 - 6 AWG	45 LB-IN
ECLK2SC NEUTRAL LUG KIT	2/0 - 6 AWG	50 LB-IN
MAIN LUG/MAIN BRKR TO BUS CONNECTION (1/4-2Ø NUT)		45 LB-IN

MAIN LUG / MAIN BREAKER KITS

DESCRIPTION	CAT. NO.
150 AMP MAIN BREAKER	MBK150A
200 AMP MAIN BREAKER	MBK200A
225 AMP MAIN BREAKER	MBK225A
150-225 AMP MAIN LUG	ECMLK225

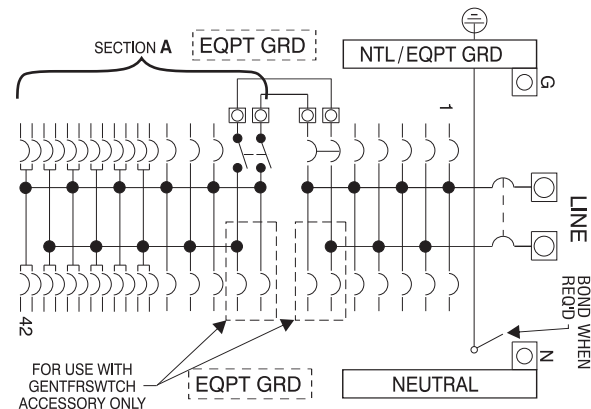
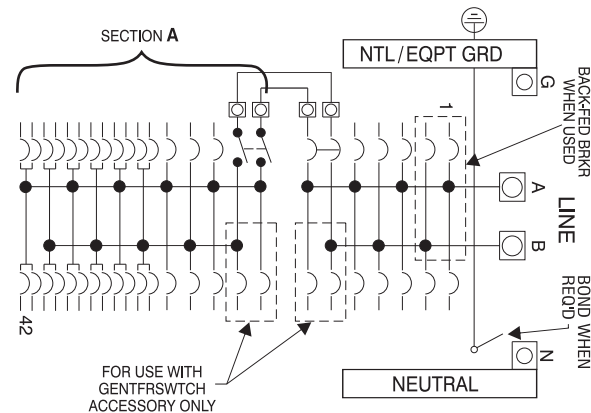

Assembled in Mexico

© 2009 Copyright Siemens Industry, Inc.

® The National Electrical Code is a registered trademark of the National Fire Protection Association.