

# Heavy Duty Safety Switch with Viewing Window

## Type VBII, 60 Amp, Type 12 Industrial and Type 4/4X Stainless Steel

### Standards and Rating

- UL Listed under file #E4776
- Meets UL98 for switches and UL50 for enclosures
- Meets NEMA Standard KS-1 for enclosed switches
- Meets NEC wire bending space requirements
- Rated 10,000 AIC with Class H fuses or 200,000 AIC with Class R and J fuses
- Rated 100,000 AIC at 600Vdc with Class R or J fuses
- I<sup>2</sup>t rated (Amps<sup>2</sup> x Seconds = 200,000)
- 12X overload current rating exceeds standard 10X industry standard
- Suitable for use as service entrance equipment

### Features

- Quick-make and break switching action
- Double break visible blade design
- Highly visible ON/OFF indication
- Window permits viewing of both visible blades and indicating type fuses
- Rugged installer friendly enclosure design
- Modular design allows quick and easy replacement of parts
- Front removable lugs which can easily be converted to copper body or compression type lugs
- Defeatable dual cover interlock

### General Information

Catalog Number	Volts	Description	Shipping Weight (lbs.)
<b>Type 12 Industrial</b> <sup>1</sup>			
HF362JW	600	3 Pole, 3 Wire, Fusible	22
HNF362JW	600	3 Pole, 3 Wire, Non-Fusible	20
<b>Type 4/4X Stainless Steel</b>			
HF362SW	600	3 Pole, 3 Wire, Fusible	23
HF362SSW <sup>6</sup>	600	3 Pole, 3 Wire, Fusible	23
HNF362SW	600	3 Pole, 3 Wire, Non-Fusible	23
HNF362SSW <sup>6</sup>	600	3 Pole, 3 Wire, Non-Fusible	23

### Horsepower Ratings<sup>2 3 4</sup> - 600 Volts

Catalog Number	3 Phase, 480V AC		3 Phase, 600V AC		250V DC
	Std	Max	Std	Max	
HF362JW	15	30	15	50	25
HF362SW	15	30	15	50	25
HF361SSW	15	30	15	50	25
HNF362JW <sup>5</sup>	—	50	—	60	25
HNF362SW <sup>5</sup>	—	50	—	60	25
HNF362SSW	—	50	—	60	25

<sup>1</sup> Also rated 3R/3S for outdoor use.

<sup>2</sup> Horsepower ratings listed also apply to Design E motors with no derating.

<sup>3</sup> Dual horsepower ratings: Std - applies when non-time delay fuses are installed.

Max - applies when time-delay fuses are installed.

<sup>4</sup> Also rated 10HP at 250V AC systems.

<sup>5</sup> Also rated 20HP on 3Ø, 240V AC systems

<sup>6</sup> The enclosure of catalog numbers HF362SSW and HNF362SSW is constructed from 316 grade stainless steel.

## Product Specification Sheet HD60.5

Answers for industry.

**SIEMENS**

# Product Specification Sheet #HD60.5 (page 2 of 3)

## Accessories

Catalog Number	Description
HA161234	One Normally Open and Closed Auxiliary Switches
HA261234	Two Normally Open and Closed Auxiliary Switches
HA361234	Low Voltage Auxiliary Switch
HG61234	Equipment Ground Lug Kit (Factory installed)
HG261234	Isolated Equipment Ground Lug Kit
HP62	Fuse Puller
HN623	Neutral Kit
HR62	600 Volt Class R Fuse Clip Kit (3 fuse clips per kit)
HLC612	Copper Lug Kit (9 lugs per kit)
HCL623	Compression Lug Neutral Barrier Kit
SSH100	1.00" Type 12 and 4X Hub
SSH150	1.50" Type 12 and 4X Hub

## Replacement Parts

Catalog Number	Description
HFB62	Fusible Line Side Replacement Base (HF362JW, HF362SW)
HBB62	Fusible Load Side Replacement Base (HF362JW, HF362SW)
HNB623	Non-Fusible 600 Replacement Base (HNF362JW, HNF362SW)
HH6123	Replacement Handle/Handle Guard (HH6123S for Type 4X)
HL612	Replacement Lugs (3 lugs per kit)
HM6123	Replacement Mechanism (HM6123S for Type 4X)
1	Replacement Door

## Mechanical Lug Wire Ranges (60/75°C, Cu/Al)

Description	Wire Range
Line, Load	#12-2 AWG (Al) or
Neutral	#14-2 AWG (Cu)
Ground	#14-4 AWG

## Compression Lugs <sup>2</sup>

Wire Size	Burndy		Thomas-Betts		Ilsco	
	CU Only	CU/AL	CU Only	CU/AL	CU Only	CU/AL
#14-10			256-30695-1352	60097		
#8	YA8C-L1 BOX	YA8CA3	54130	60102		ACL-8
	YA8C-TC14		54930BE	61102		
#6	YA6C-L BOX	YA6CA1	54105	60107	CRB-6	ACL-6
	YA6C		54905BE	61107	CRB-6L	
#4			54106	61112	CRB-4	

<sup>1</sup> Place "DOOR" at the end of the switch catalog number.

<sup>2</sup> If compression lugs are used for the neutral, order compression lug neutral barrier kit HCL623.

# Product Specification Sheet #HD60.5 (page 3 of 3)

## Dimension Drawing

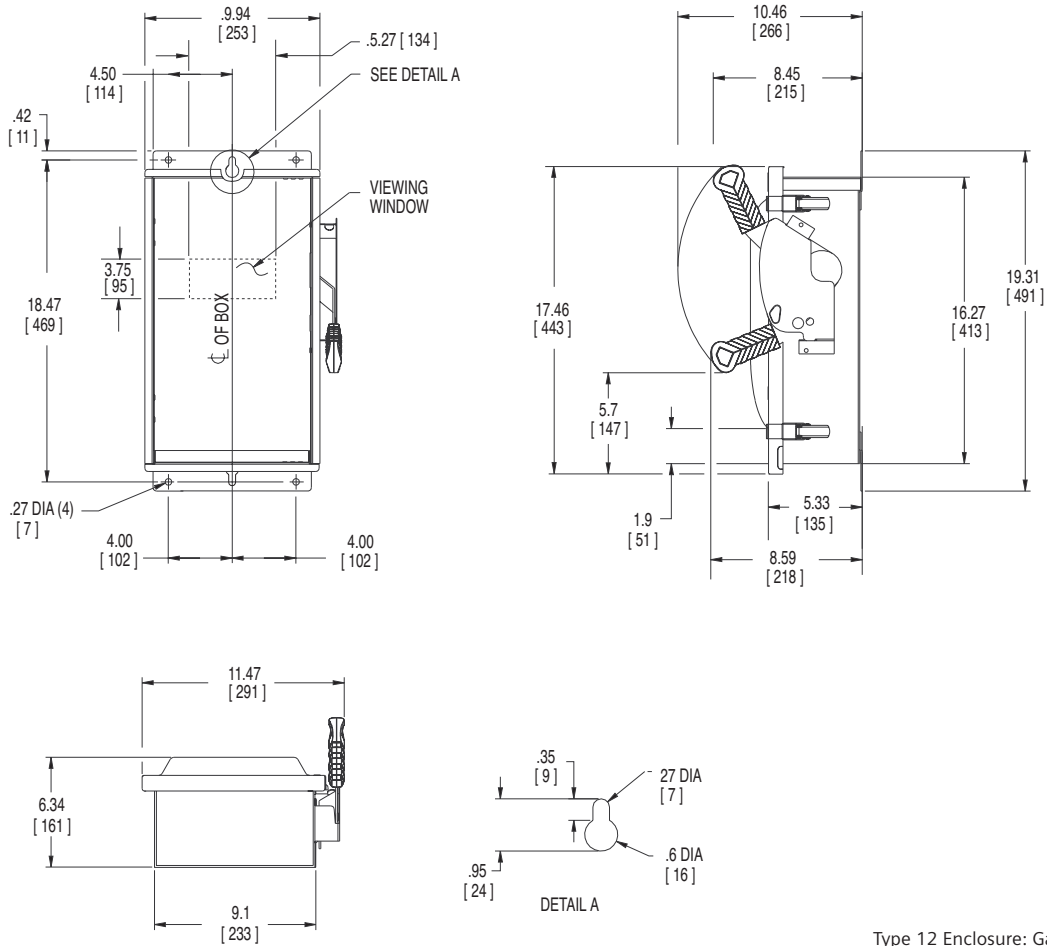

No knockouts in the enclosure.  
 Dimensions shown in inches and millimeters ( ).  
 Dimension shown accurate to ± 1/16 inch.

	LINE SIDE WIRE BEND	LOAD SIDE WIRE BEND
600V Fused	3.54 (90)	3.57 (91)
Non-Fused	3.54 (90)	8.68 (220)

Type 12 Enclosure: Galvanized Steel  
 .054 Thick (17 Gauge)  
 Finish: ANSI Grey #61 Paint  
 HF362SW and HNF362SW  
 Type 4X Enclosure: 304 Stainless Steel  
 .055 Thick (17 Gauge)  
 HF362SSW and HNF362SSW  
 Type 4X Enclosure: 316 Stainless Steel  
 .055 Thick (17 Gauge)