

# SIEMENS

*Ingenuity for life*



Product Guide

## New 400/600A Series-A Type Vacu-Break Fusible Panel- mounted Disconnect Switch

[usa.siemens.com/switches](http://usa.siemens.com/switches)

## Catalog Numbering System – New 'A' Suffix designation

### Fusible Units For SB1, SB2, and SB3 Switchboards and P5 Panelboards

V 7 E 3 2 3 3 A

**Catalog Numbering System**

**Vacu-Break Unit** → V

**Width** → 7  
 2 = 12"    7 = 17"    M = 17" (Main)

**Height** → E  
 A = 2½"    B = 5"    E = 7½"    F = 10"    H = 15"    S = 18.75"

**Number of Poles** → 3  
 2    3

**Voltage Rating** → 2  
 2 = 240V    6 = 600V

**Amperes** → 2  
 0 = Single Unit  
 Double    1 = 30A    2 = 60A    3 = 100A    4 = 200A

**Ampere Rating** → 3  
 1 = 30A    2 = 60A    3 = 100A    4 = 200A    5 = 400A    6 = 600A

**Series Type** → A  
 A = 400A, 600A    Omit = 30A–200A, 800A–1200A

Example: V7E3233 = Vacu-Break Unit, 17" Wide, 7½" High, 3-Pole, 240 Volts, Double Branch Unit with 100 Amp Rating each side. Suffix letters MS indicate Main Switch.

New Series-A Catalog Number	Replaces Legacy Catalog Number	Width (in.)	Height (in.)	Poles	Voltage (V)	Ampere Rating (A)	
<b>Branch Switches</b>							
V7H2205A <sup>①</sup>	V7H2205LR	17	15	2	240AC/250DC	400	
V7H2206A	V7H2206LR		600				
V7F3205A <sup>①</sup>	V7H3205 / V7H3205750		10	3	240AC/250DC	400	
V7H3205A			15			600	
V7H3206A	V7H3206		10			600AC	400
V7F3605A <sup>②</sup>	V7H3605 / V7H3605750		15				400
V7H3605A			600				
V7H3606A	V7H3606					600	
<b>Main Switches</b>							
V7H2205MSA	V7H2205MS	17	15	2	240AC/250DC	400	
V7H2206MSA	V7H2206MS					600	
V7H3205MSA	V7H3205MS			3	240AC/250DC	400	
V7H3206MSA	V7H3206MS					600	
V7H3605MSA	V7H3605MS				600AC	400	
V7H3606MSA	V7H3606MS					600	

① 3 pole compact switch (V7F3205A) can be utilized for 2 pole applications.  
 ② Compact (10") switch will not accept R-class 600V fuses, utilize 15" version (V7H3605A).



Series-A 400A and 600A Vacu-Break switches are the first release of the next generation Fusible Panelboard switches

## NEW Series-A Highlights

### Smaller Size

- New 10" compact 400A switches are 33% smaller than legacy switches

### Easier And More Flexible Installation

- Bidirectional mounting accepts load cabling on left or right side of panel
- Standard 750 kcmil lugs
- "Lay-in" style lugs for fast cabling (15" version)
- Built in J-class fuse compatibility for 400A switch, no adapter kit needed

### Improved Performance

- Double break, visible switching action
- Meets NFPA 79 - defeatable ON/OFF with the door open
- Backward compatible with legacy switch

## Standards and Ratings

- UL listed under file #E6849. Meets UL98 standard for enclosed and deadfront switches
- Meets NEMA Standard KS-1-2001 for type HD switches
- Uninsulated live part spacings per UL98
- Rated up to 200,000A when protected by Class R, J or T fuses
- Meets NFPA 79 - defeatable ON/OFF with the door open
- Max I<sup>2</sup>t for 400A switch is 6,000,000 Amps<sup>2</sup> x seconds
- Max I<sup>2</sup>t for 600A switch is 12,000,000 Amps<sup>2</sup> x seconds
- 6X overload current rating

## Features

- Double-break switching action
  - Reduces heat generation and increases switching speed
  - Enhanced performance and increased longevity
  - Self-aligning knife blades ensure positive contact
- Visible blade design
- Highly visible ON/OFF indication
- KIRK™ key integration option
- 750 kcmil lugs standard for 10" and 15" switches
- Spring loaded heat sink fuse clip
- Lay in Lugs for easy cabling (15" switches)
- Pressure terminal connections on load side suitable for aluminum or copper wire
- Moveable base eliminates need for J-class fuse kit
- Backward compatible with legacy switches
- Bidirectional mounting accepts load cabling on left or right side of panel

## Double Break Switching Action

Like the time-proven Vacu-Break Design, the Siemens VBII double break switching action breaks the arc in

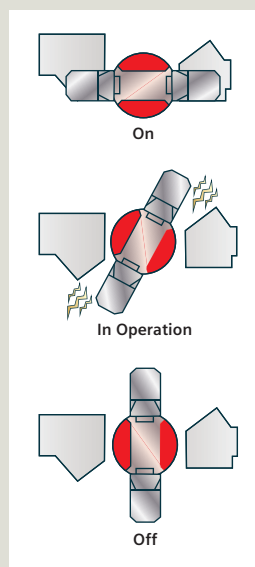

multiple places, 2 sets of blades per phase (400A) or 3 sets of blades per phase (600A). This reduces heat generation and increases switching speed by doubling the breaking distance. The result is enhanced performance and increased longevity. We also provide the most visible blade design available today. Unlike conventional knife blade switches, the blades are self-aligning to ensure positive contact. In addition, they have no wear and friction point since the "electrical hinge" has been

eliminated. The result is a very fast positive and reliable switching action for even the most severe applications.

## Dimensions and Weights

New Series-A Catalog Numbers	Dimensions (inches)			Shipping Weight (lb)
	Width	Height	Depth	

### Branch Switches

V7H2205A	17	15	10.5	44
V7H2206A				
V7F3205A		10		35
V7H3205A				
V7H3206A		15		44
V7F3605A		10		
V7H3605A		15		44
V7H3606A				

### Main Switches

V7H2205MSA	17	15	10.5	44
V7H2206MSA				
V7H3205MSA				
V7H3206MSA				
V7H3605MSA				
V7H3606MSA				

## Fuse and Conductors

New Series A Catalog Numbers	Lug Wire Range	Poles	Voltage (V)	Ampere Rating (A)	Fuse Classes	Line Bus Connection	Load Bus Connection
---------------------------------	----------------	-------	-------------	-------------------	-----------------	------------------------	------------------------

### Branch Switches

V7H2205A	(2)-#1/0 to 750 kcmil or (4)-#1/0 to #4/0	2	240VAC/250VDC	400	H,R,J,T	Rear	N/A	
V7H2206A				600				
V7F3205A	(1)-#1/0 to 750 kcmil or (2)-#1/0 to 300 kcmil	3	240VAC/250DC	400	H,J,T			
V7H3205A				(2)-#1/0 to 750 kcmil or (4)-#1/0 to #4/0	600			H,R,J,T
V7H3206A								
V7F3605A	(1)-#1/0 to 750 kcmil or (2)-#1/0 to 300 kcmil			600VAC	400			H,J,T
V7H3605A	(2)-#1/0 to 750 kcmil or (4)-#1/0 to #4/0				600			H,R,J,T
V7H3606A								

### Main Switches

V7H2205MSA	Bus Connection Only	2	240VAC/250VDC	400	H,R,T	N/A	Rear	
V7H2206MSA				600	H,R,J,T			
V7H3205MSA		3	240VAC/250DC	400	H,R,T			
V7H3206MSA				600	H,R,J,T			
V7H3605MSA				600VAC				400
V7H3606MSA								600

Switch Rating	Maximum Withstand Ratings (Amperes) – 240V AC					Maximum Withstand Ratings (Amperes) – 600V AC				
	H.K. Fuses	R Fuses	J Fuses	L Fuses	T Fuses	H.K. Fuses	R Fuses	J Fuses	L Fuses	T Fuses
400	10,000	200,000	200,000	—	200,000	10,000	200,000	200,000	—	200,000
600	10,000	200,000	200,000	—	200,000	10,000	200,000	200,000	—	200,000

## Fuse Adapter Kits

New Series A Catalog Numbers	Class R <sup>②</sup>	Class T <sup>③</sup>	Class J <sup>②</sup>
------------------------------	----------------------	----------------------	----------------------

### Branch Switches

V7H2205A	HR65A	HT25A	Relocate Base
V7H2206A	HR66A	HT26A	RB <sup>①</sup> +HJ66A
V7F3205A	HR65A	HT25A	Relocate Base
V7H3205A			
V7H3206A	HR66A	HT26A	RB <sup>①</sup> +HJ66A
V7F3605A	HR65A	HT265A	Relocate Base
V7H3605A		HT65A	
V7H3606A	HR66A	HT66A	HJ66A

### Main Switches

V7H2205MSA	HR65A	HT25A	NA
V7H2206MSA	HR66A	HT26A	
V7H3205MSA	HR65A	HT25A	
V7H3206MSA	HR66A	HT26A	
V7H3605MSA	HR65A	HT65A	HJ65A
V7H3606MSA	HR66A	HT66A	

- ① RB: Relocate Base
- ② One Kit Per Switch
- ③ One Kit Per Phase

## Horsepower Ratings

Not for use as a motor control over 74.6 kW (100hp).

Continuous load current not to exceed 80% of the rating of the fuses employed in other than motor circuits.

The starting current of motors of more than the standard horsepower or kilowatt ratings may require the use of fuses with appropriate time-delay characteristics.

Catalog Number	Pole	Ampere Rating	250 Volt DC	Horsepower Rating		Horsepower Rating			
				240 Volt AC		480 Volt AC		600 Volt AC	
				Standard	Maximum	Standard	Maximum	Standard	Maximum

### Branch Switches

V7H2205A	2	400	50	—	—	100	250	125	350		
V7F3205A	3			600	—					50	125
V7H3205A											
V7F3605A											
V7H3605A											
V7H2206A	2	600	—	—	—	150	400	200	500		
V7H3206A	3			75	200						
V7H3606A											

### Main Switches

V7H2205MSA	2	400	50	—	—	100	250	125	350
V7H3205MSA	3			75	200				
V7H3605MSA									
V7H2206MSA	2	600	—	—	—	150	400	200	500
V7H3206MSA	3			75	200				
V7H3606MSA									

## Replacement Part Kits

New Series A Catalog Numbers	Loose Parts Replacement Kit (Barrier and Hardware)	Load Base	Lug / Lug Cap Kit ①
<b>Branch Switches</b>			
V7H2205A	V7HBK656A	V7HBB65A	V7HL65A
V7H2206A		V7HBB66A	V7HL66A
V7F3205A	V7FBK656A	V7FBB65A	V7FL65A
V7H3205A	V7HBK656A	V7HBB65A	V7HL65A
V7H3206A		V7HBB66A	V7HL66A
V7F3605A	V7FBK656A	V7FBB65A	V7FL65A
V7H3605A	V7HBK656A	V7HBB65A	V7HL65A
V7H3606A		V7HBB66A	V7HL66A
<b>Main Switches</b>			
V7H2205MSA	V7HBK656A	NA	NA
V7H2206MSA			
V7H3205MSA			
V7H3206MSA			
V7H3605MSA			
V7H3606MSA			

① One kit per switch

**Load base  
10" version (400A)**



**Load base  
15" version (400A/600A)**

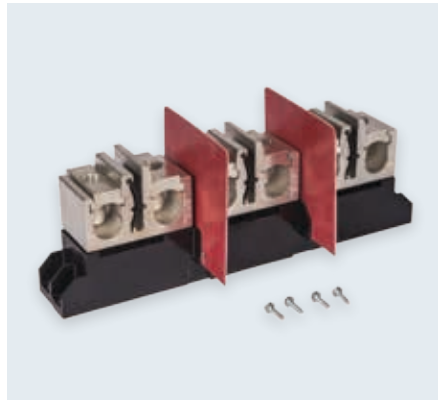

**Loose Parts  
Replacement Kit**



### 10 inch, 400A Dimensions

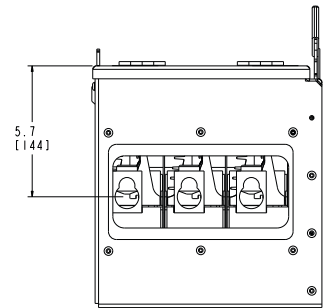
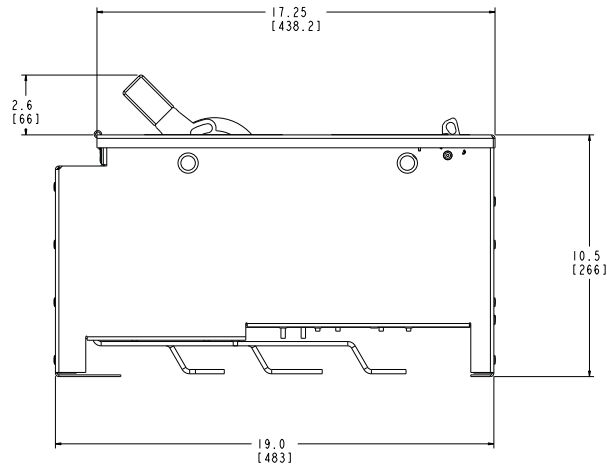
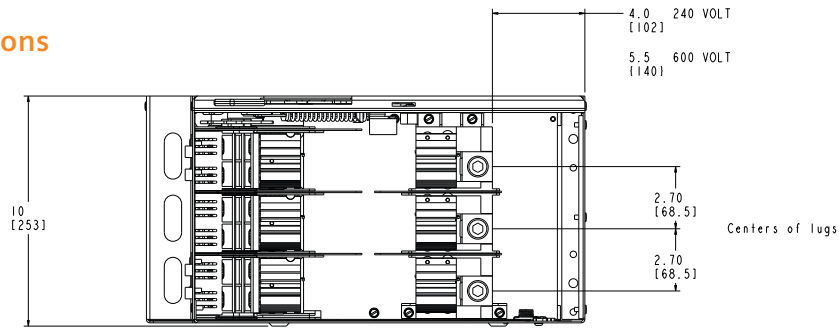

Enclosure:  
Galvanized Steel .075 thick minimum  
Finish: ANSI Grey #61 Paint

Dimensions shown in inches and millimeters [ ].  
Dimensions shown accurate to ± 1/8 inch.

### 15 inch, 400A/600A Dimensions

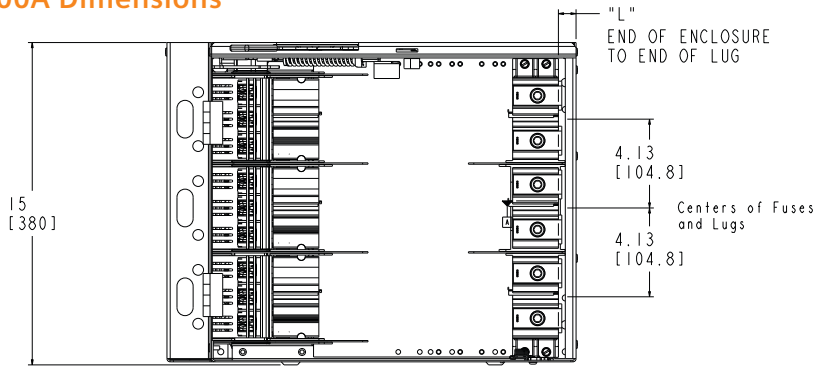

AMPERAGE	VOLTAGE	DISTANCE "L"
400	240	5.57 [141.5]
400	600	2.57 [65.3]
600	240	3.82 [97.0]
600	600	0.82 [20.8]

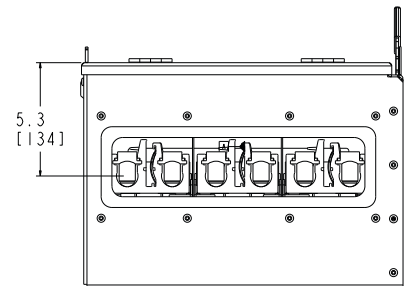
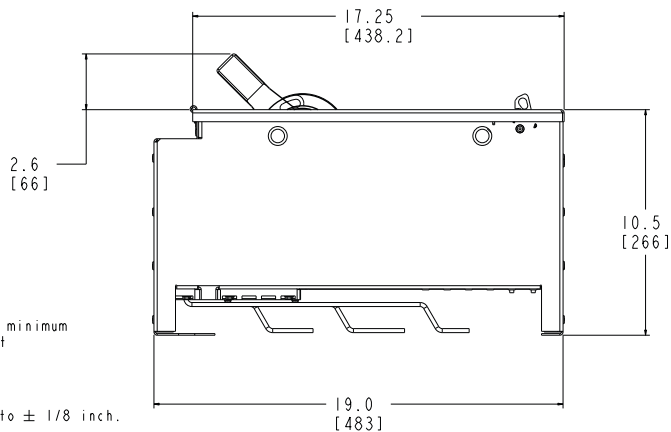

Enclosure:  
Galvanized Steel .075 thick minimum  
Finish: ANSI Grey #61 Paint

Dimensions shown in inches and millimeters [ ].  
Dimensions shown accurate to ± 1/8 inch.

**Published by  
Siemens 2018**

Siemens Industry, Inc.  
5400 Triangle Parkway  
Norcross, GA 30092

Siemens Technical Support: 1-800-333-7421  
[info.us@siemens.com](mailto:info.us@siemens.com)

Printed in USA  
Order No. SSBR-46PBS-0918-CP  
All Rights Reserved  
© 2018, Siemens Industry, Inc.  
[usa.siemens.com/switches](http://usa.siemens.com/switches)

The technical data presented in this document is based on an actual case or on as-designed parameters, and therefore should not be relied upon for any specific application and does not constitute a performance guarantee for any projects. Actual results are dependent on variable conditions. Accordingly, Siemens does not make representations, warranties, or assurances as to the accuracy, currency or completeness of the content contained herein. If requested, we will provide specific technical data or specifications with respect to any customer's particular applications. Our company is constantly involved in engineering and development. For that reason, we reserve the right to modify, at any time, the technology and product specifications contained herein.