

## Catalog Numbers, Features and Ratings

- 1 PHASE, 3 WIRE, 120/240V ~
- G3042B1200GEN: 22K AIC MAIN BREAKER FACTORY INSTALLED (SEE WIRING DIAGRAM FOR DETAILS)
- G3042L1225GEN: 100K AIC MAX. RATED (SEE WIRING DIAGRAM FOR DETAILS)
- CONVERTIBLE TO MAIN LUG/ MAIN BREAKER
- INVERTIBLE
- TYPE N1 INDOOR ENCLOSURE
- ANSI 61 GRAY POWDER COATED



Catalog Number	ENCLOSURE DIMS			Amps Max	Number Spaces	Number Circuits	Bus Bar Material	Bus Bar Plating	Percent Neutrals
	L	W	D						
G3042B1200GEN	42.00	14.25	3.88	200	30	42	Copper	Tin Plated	100%
G3042L1225GEN	42.00	14.25	3.88	225	30	42	Copper	Tin Plated	100%

### G3042B1200GEN

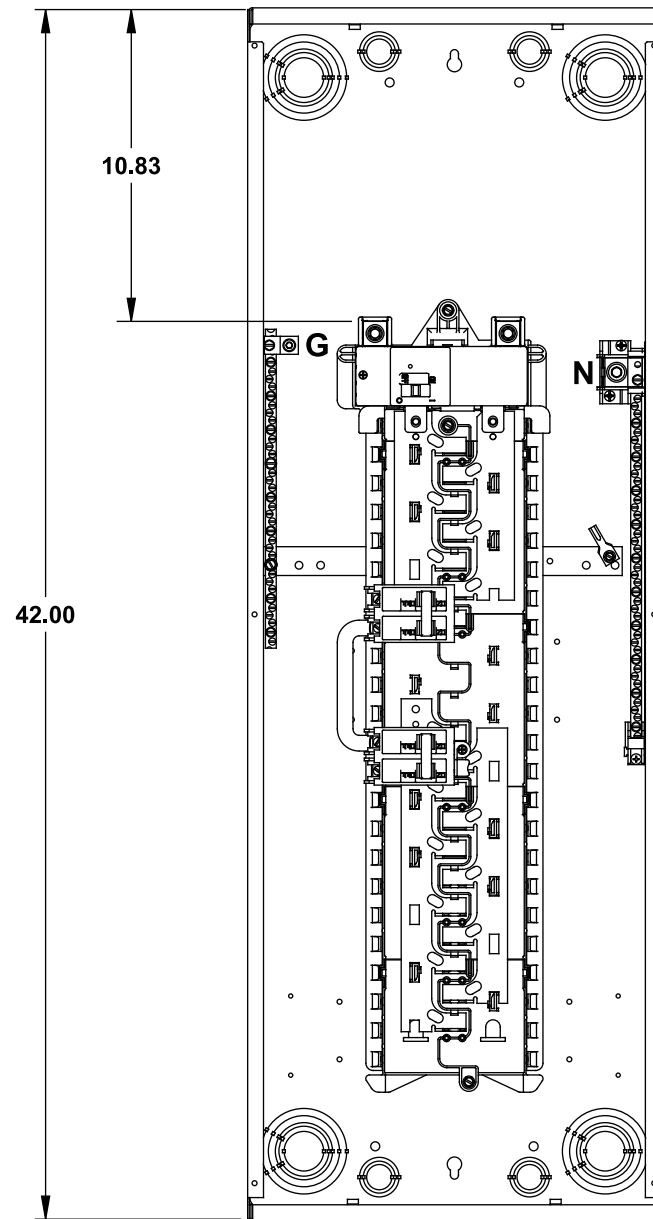

### G3042L1225GEN

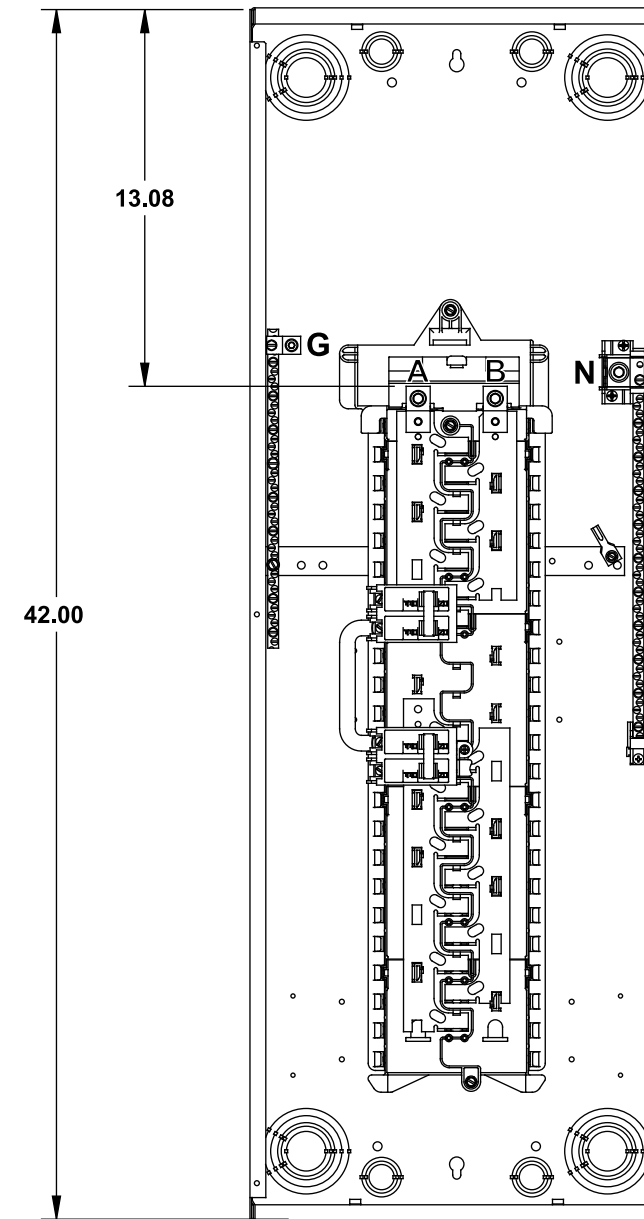

### Trim/Door Detail

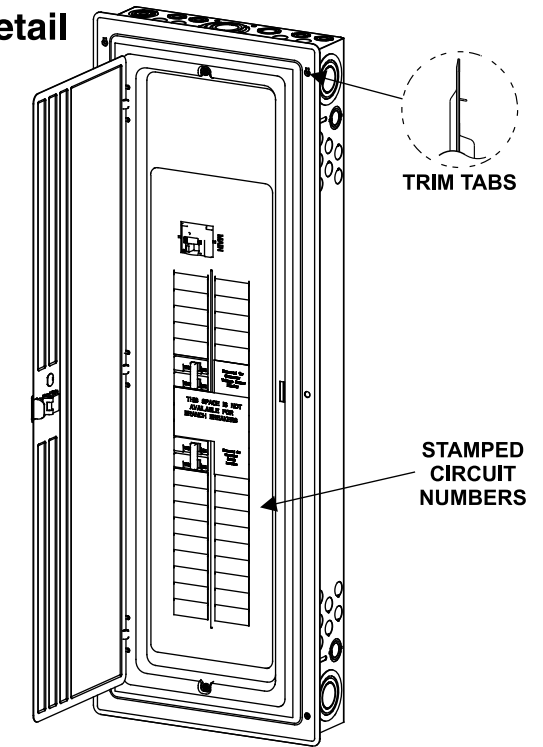

### KO Diagram

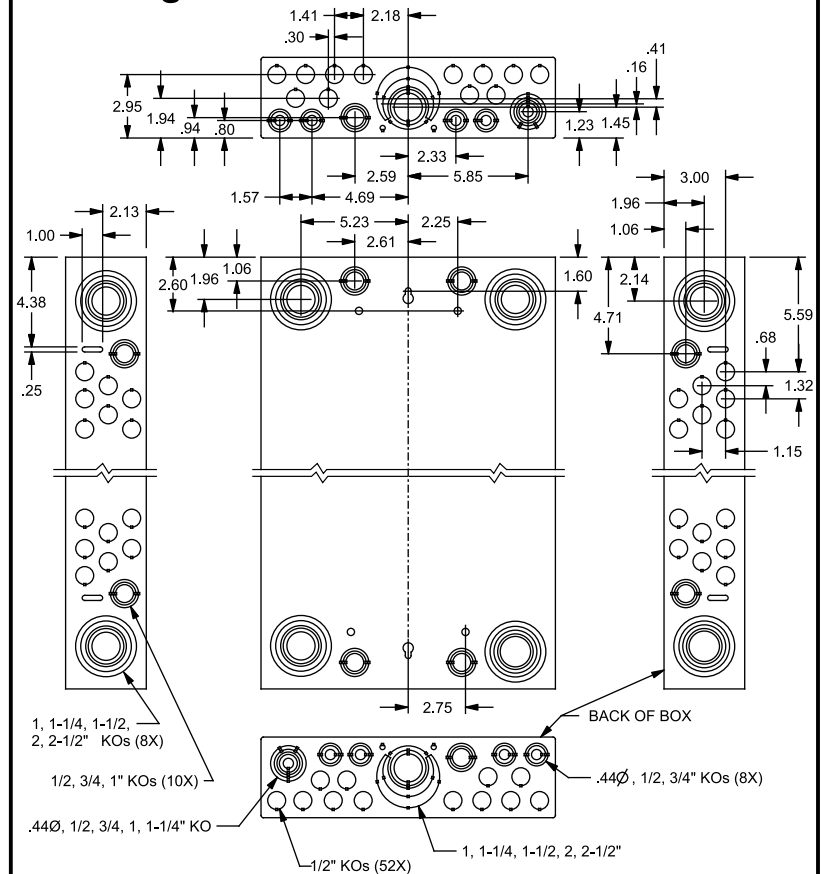

### SCHEMATICS

#### G3042B1200GEN

"SECTION A" IS RATED 125A MAX.

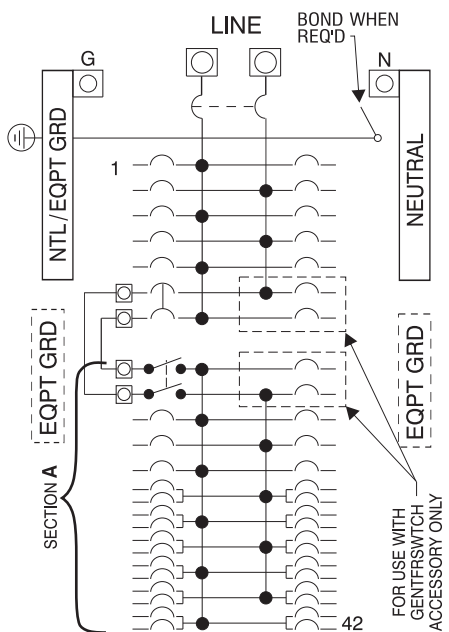

#### G3042L1225GEN

"SECTION A" IS RATED 125A MAX.

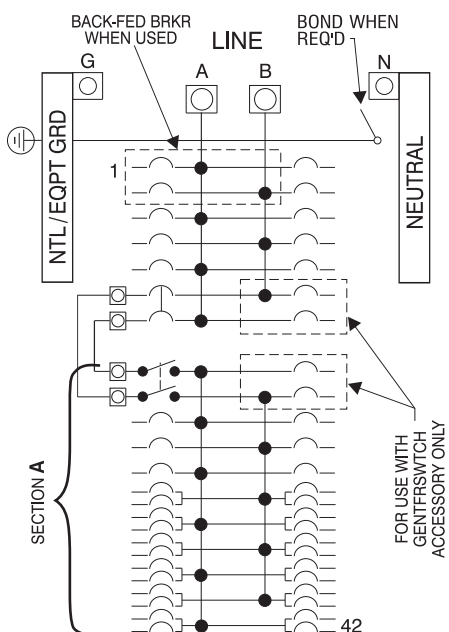

### TERMINAL WIRE SIZES AND TORQUES

USE COPPER OR ALUMINUM 60°/75°C WIRE  
SEE BREAKER MARKINGS FOR WIRE SIZE AND TORQUE REQUIREMENTS.

**EQUIPMENT GROUND BAR**  
TERMINALS ARE SUITABLE FOR THE FOLLOWING WIRE COMBINATIONS:  
**SMALL TERMINALS:** ONE 14 TO 6 AWG CU; ONE 12 TO 6 AWG AL; TWO 14 AWG CU; TWO 12 AWG CU; TWO 12 AWG AL SOLID WIRES.  
**LARGE TERMINALS:** ONE 14 TO 2 AWG CU; ONE 12 TO 2 AWG AL; TWO OR THREE 14 AWG CU; TWO OR THREE 12 AWG CU OR AL; TWO 10 AWG CU; TWO OR THREE 10 AWG AL; THREE 10 AWG CU SOLID WHEN TORQUED TO 50 LB-IN; THREE 10 AWG CU STRANDED.

TERMINALS	WIRE	TORQUE
A, B	300 kcmil-4 AWG	275 LB-IN
N	300 kcmil-4 AWG	250 LB-IN
G	2/0 - 6 AWG	90 LB-IN
NEUTRAL AND EQPT GROUND BAR		
SMALL TERMINALS	10 - 14 AWG	20 LB-IN
	8 AWG	25 LB-IN
	6 AWG	35 LB-IN
LARGE TERMINALS	10 - 14 AWG	35 LB-IN
	8 AWG	40 LB-IN
	1/0 - 6 AWG	45 LB-IN
ECLK2SC NEUTRAL LUG KIT	2/0 - 6 AWG	50 LB-IN
MAIN LUG/MAIN BRKR TO BUS CONNECTION (1/4-20 NUT)		45 LB-IN

### ACCESSORIES

REFER TO WIRING DIAGRAM FOR CORRECT ACCESSORY USAGE

DESCRIPTION	CATALOG NO.
DOOR LOCK	ECOF12
FILLER PLATE, 1"	QF3
BREAKER HOLD-DOWN	ECMBR2
GROUND BAR KITS	USE "ECLX" SERIES
GENERATOR TRANSFER SWITCH	GENTFRSWTCH

DESCRIPTION	CAT. NO.
150 AMP MAIN BREAKER	MBK150A
200 AMP MAIN BREAKER	MBK200A
225 AMP MAIN BREAKER	MBK225A
150-225 AMP MAIN LUG	ECMLK225

© 2016 Copyright Siemens Industry, Inc.

**SIEMENS**  
Siemens Industry, Inc.

### Generator Ready Load Centers

Description: **1 Phase, Indoor,  
30 Position, 42 Circuit Cut Sheet**

KAM 9/1/16 DO NOT SCALE DRAWING Dwg No: **1IN 30 GEN**