

NAME: LATIRX OBJECT: HNB678 DATE: 20-Oct-09 10:49:48

NOTE:

1. PLACE COATED SCREWS, ITEM 6, AND INSTRUCTION SHEET, ITEM 2, IN SHIPPING BAG, ITEM 10.
2. WRAP LINE SHIELD IN WAX PAPER, ITEM 3, AND PLACE IN CARTON, ITEM 8.
3. PLACE CARTON PAD, ITEM 4, LINE BASE ASSEMBLY, ITEM 9, AND COMPLETED BAG ASSEMBLY, IN CARTON, ITEM 8.
4. PLACE CARTON LABEL, ITEM 5, ON COMPLETED CARTON, ITEM 8.

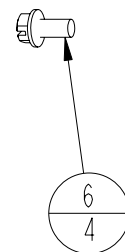
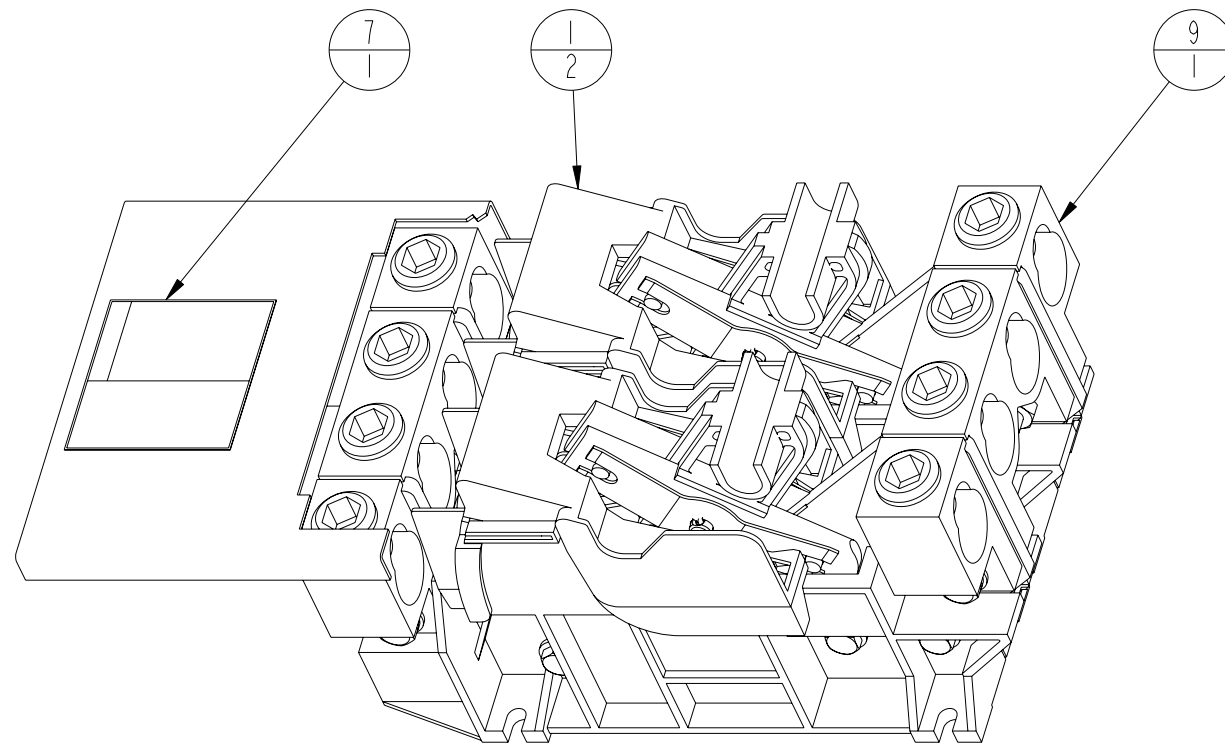

REVISIONS			
REV	DESCRIPTION	DATE	APPROVED
0P	INITIAL RELEASE	09/24/01	ECN 17090
1P	500154A00 WAS QTY. 4	05/08/02	ECN 17980
2P	ITEM 2 508218A01 WAS A00	10/22/09	ECN 21306

FIND NO.	QTY REQD	PART OR IDENTIFYING NO.	NOMENCLATURE OR DESCRIPTION
10	1	49990105	BAG, SHIPPING 5 X 7
9	1	LIBK1200NF	LINE BASE ASSEMBLY NON-FUSED 1200AMP
8	1	58576C00	CARTON REPLACEMENT PART
7	1	508126B00	LABEL, LINE SHIELD WARNING 400-1200 AMP
6	4	500154A00	COATED SCREW 1/4-20 X 1/2"
5	1	4912-SIZE4	LABEL, CARTON, SIZE 4
4	1	4800-1425A01	PACKAGING MATERIAL CORRUGATED CARTONS REPLACEMENT PART
3	1	4251-0034	MICROFOAM 16 X 18 DU PONT
2	1	508218A01	INSTRUCTION SHEET 800/1200A LINE BASE REPLACEMENT KIT
1	2	508141A00	BARRIER TOP LINEBASE 400/600 AMP

PARTS LIST  
ASSEMBLY NUMBER - HNB678

CONFIDENTIAL- PROPERTY OF Siemens Industry, Inc.

Siemens Industry, Inc.

REPLACEMENT PART KIT  
800/1200 AMP NONFUSED LINE BASE

UNLESS OTHERWISE SPECIFIED DIMENSIONS ARE IN INCHES DO NOT SCALE DRAWING	THIRD ANGLE PROJ.		
TOLERANCES: .XX ± 0.01 .XXX ± 0.001 ANGULAR ± 1.0°	DWN DAF	DATE 08/30/01	SIZE <b>B</b>
	CHK DAF	DATE 06/22/01	FSCM NO.
	APVD NAFTA	DATE 06/25/01	DWG NO. <b>HNB678</b>
		SCALE: 0.375	PRO/E FILE: HNB678
			SHEET 1 OF 1