



Circuit breaker size S00 for transformer protection A-release 1.8...2.5 A N release 52 A screw terminal Standard switching capacity with transverse auxiliary switches 1 NO+1 NC

product brand name	SIRIUS
product designation	Circuit breaker
design of the product	For transformer protection
product type designation	3RV2
<b>General technical data</b>	
size of the circuit-breaker	S00
size of contactor can be combined company-specific	S00, S0
product extension auxiliary switch	Yes
power loss [W] for rated value of the current	
• at AC in hot operating state	7.25 W
• at AC in hot operating state per pole	2.4 W
insulation voltage with degree of pollution 3 at AC rated value	690 V
surge voltage resistance rated value	6 kV
shock resistance according to IEC 60068-2-27	25g / 11 ms
mechanical service life (operating cycles)	
• of the main contacts typical	100 000
• of auxiliary contacts typical	100 000
electrical endurance (operating cycles) typical	100 000
reference code according to IEC 81346-2	Q
Substance Prohibitance (Date)	10/01/2009
<b>Ambient conditions</b>	
installation altitude at height above sea level maximum	2 000 m
ambient temperature	
• during operation	-20 ... +60 °C
• during storage	-50 ... +80 °C
• during transport	-50 ... +80 °C
relative humidity during operation	10 ... 95 %
<b>Main circuit</b>	
number of poles for main current circuit	3
adjustable current response value current of the current-dependent overload release	1.8 ... 2.5 A
operating voltage	
• rated value	20 ... 690 V
• at AC-3 rated value maximum	690 V
• at AC-3e rated value maximum	690 V
operating frequency rated value	50 ... 60 Hz
operational current rated value	2.5 A
operational current	
• at AC-3 at 400 V rated value	2.5 A
• at AC-3e at 400 V rated value	2.5 A

<b>operating power</b>	
<ul style="list-style-type: none"> <li>● at AC-3 <ul style="list-style-type: none"> <li>— at 230 V rated value</li> <li>— at 400 V rated value</li> <li>— at 500 V rated value</li> <li>— at 690 V rated value</li> </ul> </li> <li>● at AC-3e <ul style="list-style-type: none"> <li>— at 230 V rated value</li> <li>— at 400 V rated value</li> <li>— at 500 V rated value</li> <li>— at 690 V rated value</li> </ul> </li> </ul>	<ul style="list-style-type: none"> <li>0.4 kW</li> <li>0.8 kW</li> <li>1.1 kW</li> <li>1.5 kW</li> <li>0.4 kW</li> <li>0.8 kW</li> <li>1.1 kW</li> <li>1.5 kW</li> </ul>
<b>operating frequency</b>	
<ul style="list-style-type: none"> <li>● at AC-3 maximum</li> <li>● at AC-3e maximum</li> </ul>	<ul style="list-style-type: none"> <li>15 1/h</li> <li>15 1/h</li> </ul>
<b>Auxiliary circuit</b>	
<b>design of the auxiliary switch</b>	transverse
<b>number of NC contacts for auxiliary contacts</b>	1
<b>number of NO contacts for auxiliary contacts</b>	1
number of CO contacts for auxiliary contacts	0
<b>operational current of auxiliary contacts at AC-15</b>	
<ul style="list-style-type: none"> <li>● at 24 V</li> <li>● at 120 V</li> <li>● at 125 V</li> <li>● at 230 V</li> </ul>	<ul style="list-style-type: none"> <li>2 A</li> <li>0.5 A</li> <li>0.5 A</li> <li>0.5 A</li> </ul>
<b>operational current of auxiliary contacts at DC-13</b>	
<ul style="list-style-type: none"> <li>● at 24 V</li> <li>● at 60 V</li> </ul>	<ul style="list-style-type: none"> <li>1 A</li> <li>0.15 A</li> </ul>
<b>Protective and monitoring functions</b>	
<b>product function</b>	
<ul style="list-style-type: none"> <li>● ground fault detection</li> <li>● phase failure detection</li> </ul>	<ul style="list-style-type: none"> <li>No</li> <li>Yes</li> </ul>
<b>trip class</b>	CLASS 10
<b>design of the overload release</b>	thermal
<b>maximum short-circuit current breaking capacity (Icu)</b>	
<ul style="list-style-type: none"> <li>● at AC at 240 V rated value</li> <li>● at AC at 400 V rated value</li> <li>● at AC at 500 V rated value</li> <li>● at AC at 690 V rated value</li> </ul>	<ul style="list-style-type: none"> <li>100 kA</li> <li>100 kA</li> <li>100 kA</li> <li>10 kA</li> </ul>
<b>operating short-circuit current breaking capacity (Ics) at AC</b>	
<ul style="list-style-type: none"> <li>● at 240 V rated value</li> <li>● at 400 V rated value</li> <li>● at 500 V rated value</li> <li>● at 690 V rated value</li> </ul>	<ul style="list-style-type: none"> <li>100 kA</li> <li>100 kA</li> <li>100 kA</li> <li>10 kA</li> </ul>
response value current of instantaneous short-circuit trip unit	52 A
<b>UL/CSA ratings</b>	
<b>full-load current (FLA) for 3-phase AC motor</b>	
<ul style="list-style-type: none"> <li>● at 480 V rated value</li> <li>● at 600 V rated value</li> </ul>	<ul style="list-style-type: none"> <li>2.5 A</li> <li>2.5 A</li> </ul>
<b>yielded mechanical performance [hp]</b>	
<ul style="list-style-type: none"> <li>● for single-phase AC motor <ul style="list-style-type: none"> <li>— at 230 V rated value</li> </ul> </li> <li>● for 3-phase AC motor <ul style="list-style-type: none"> <li>— at 200/208 V rated value</li> <li>— at 220/230 V rated value</li> <li>— at 460/480 V rated value</li> <li>— at 575/600 V rated value</li> </ul> </li> </ul>	<ul style="list-style-type: none"> <li>0.17 hp</li> <li>0.5 hp</li> <li>0.5 hp</li> <li>1 hp</li> <li>1.5 hp</li> </ul>
<b>contact rating of auxiliary contacts according to UL</b>	C300 / R300
<b>Short-circuit protection</b>	
<b>product function short circuit protection</b>	Yes
<b>design of the short-circuit trip</b>	magnetic

<b>design of the fuse link</b>	
<ul style="list-style-type: none"> <li>for short-circuit protection of the auxiliary switch required</li> </ul>	Fuse gL/gG: 10 A, miniature circuit breaker C 6 A (short-circuit current $I_k < 400$ A)
<b>design of the fuse link for IT network for short-circuit protection of the main circuit</b>	
<ul style="list-style-type: none"> <li>at 400 V</li> <li>at 500 V</li> <li>at 690 V</li> </ul>	gL/gG 25 A gL/gG 25 A gL/gG 20 A
<b>Installation/ mounting/ dimensions</b>	
<b>mounting position</b>	any
<b>fastening method</b>	screw and snap-on mounting onto 35 mm DIN rail according to DIN EN 60715
<b>height</b>	97 mm
<b>width</b>	45 mm
<b>depth</b>	97 mm
<b>required spacing</b>	
<ul style="list-style-type: none"> <li>with side-by-side mounting at the side</li> <li>for grounded parts at 400 V               <ul style="list-style-type: none"> <li>downwards</li> <li>upwards</li> <li>at the side</li> </ul> </li> <li>for live parts at 400 V               <ul style="list-style-type: none"> <li>downwards</li> <li>upwards</li> <li>at the side</li> </ul> </li> <li>for grounded parts at 500 V               <ul style="list-style-type: none"> <li>downwards</li> <li>upwards</li> <li>at the side</li> </ul> </li> <li>for live parts at 500 V               <ul style="list-style-type: none"> <li>downwards</li> <li>upwards</li> <li>at the side</li> </ul> </li> <li>for grounded parts at 690 V               <ul style="list-style-type: none"> <li>downwards</li> <li>upwards</li> <li>backwards</li> <li>at the side</li> <li>forwards</li> </ul> </li> <li>for live parts at 690 V               <ul style="list-style-type: none"> <li>downwards</li> <li>upwards</li> <li>backwards</li> <li>at the side</li> <li>forwards</li> </ul> </li> </ul>	0 mm  30 mm 30 mm 9 mm  30 mm 30 mm 9 mm  30 mm 30 mm 9 mm  50 mm 50 mm 0 mm 30 mm 0 mm  50 mm 50 mm 0 mm 30 mm 0 mm
<b>Connections/ Terminals</b>	
<b>type of electrical connection</b>	
<ul style="list-style-type: none"> <li>for main current circuit</li> <li>for auxiliary and control circuit</li> </ul>	screw-type terminals screw-type terminals
<b>arrangement of electrical connectors for main current circuit</b>	Top and bottom
<b>type of connectable conductor cross-sections</b>	
<ul style="list-style-type: none"> <li>for main contacts               <ul style="list-style-type: none"> <li>solid or stranded</li> <li>finely stranded with core end processing</li> </ul> </li> <li>for AWG cables for main contacts</li> </ul>	2x (0,75 ... 2,5 mm <sup>2</sup> ), 2x 4 mm <sup>2</sup> 2x (0,5 ... 1,5 mm <sup>2</sup> ), 2x (0,75 ... 2,5 mm <sup>2</sup> ) 2x (18 ... 14), 2x 12
<b>type of connectable conductor cross-sections</b>	
<ul style="list-style-type: none"> <li>for auxiliary contacts               <ul style="list-style-type: none"> <li>solid or stranded</li> <li>finely stranded with core end processing</li> </ul> </li> <li>for AWG cables for auxiliary contacts</li> </ul>	2x (0,5 ... 1,5 mm <sup>2</sup> ), 2x (0,75 ... 2,5 mm <sup>2</sup> ) 2x (0,5 ... 1,5 mm <sup>2</sup> ), 2x (0,75 ... 2,5 mm <sup>2</sup> ) 2x (20 ... 16), 2x (18 ... 14)
<b>tightening torque</b>	

<ul style="list-style-type: none"> <li>• for main contacts with screw-type terminals</li> <li>• for auxiliary contacts with screw-type terminals</li> </ul>	0.8 ... 1.2 N·m
<b>design of screwdriver shaft</b>	Diameter 5 to 6 mm
<b>size of the screwdriver tip</b>	Pozidriv size 2
<b>design of the thread of the connection screw</b>	
<ul style="list-style-type: none"> <li>• for main contacts</li> <li>• of the auxiliary and control contacts</li> </ul>	M3
	M3

### Safety related data

<b>B10 value</b>	
<ul style="list-style-type: none"> <li>• with high demand rate according to SN 31920</li> </ul>	5 000
<b>proportion of dangerous failures</b>	
<ul style="list-style-type: none"> <li>• with low demand rate according to SN 31920</li> <li>• with high demand rate according to SN 31920</li> </ul>	50 %
	50 %
<b>failure rate [FIT]</b>	
<ul style="list-style-type: none"> <li>• with low demand rate according to SN 31920</li> </ul>	50 FIT
T1 value for proof test interval or service life according to IEC 61508	10 a
<b>protection class IP on the front according to IEC 60529</b>	IP20
<b>touch protection on the front according to IEC 60529</b>	finger-safe, for vertical contact from the front
display version for switching status	Handle

### Certificates/ approvals

<b>General Product Approval</b>	<b>Declaration of Conformity</b>
---------------------------------	----------------------------------

[Confirmation](#)



[KC](#)



<b>Declaration of Conformity</b>	<b>Test Certificates</b>	<b>Marine / Shipping</b>
----------------------------------	--------------------------	--------------------------



[Type Test Certificates/Test Report](#)

[Special Test Certificate](#)



<b>Marine / Shipping</b>	<b>other</b>	<b>Railway</b>
--------------------------	--------------	----------------



[Confirmation](#)



[Confirmation](#)

### Railway

[Vibration and Shock](#)

### Further information

Siemens has decided to exit the Russian market (see here).

<https://press.siemens.com/global/en/pressrelease/siemens-wind-down-russian-business>

Siemens is working on the renewal of the current EAC certificates.

Please contact your local Siemens office on the status of validity of the EAC certification if you intend to import or offer to supply these products to an EAC relevant market (other than the sanctioned EAEU member states Russia or Belarus).

Information on the packaging

<https://support.industry.siemens.com/cs/ww/en/view/109813875>

Information- and Downloadcenter (Catalogs, Brochures,...)

<https://www.siemens.com/ic10>

Industry Mall (Online ordering system)

<https://mall.industry.siemens.com/mall/en/en/Catalog/product?mlfb=3RV2411-1CA15>

Cax online generator

<http://support.automation.siemens.com/WW/CAXorder/default.aspx?lang=en&mlfb=3RV2411-1CA15>

Service&Support (Manuals, Certificates, Characteristics, FAQs,...)

<https://support.industry.siemens.com/cs/ww/en/ps/3RV2411-1CA15>

Image database (product images, 2D dimension drawings, 3D models, device circuit diagrams, EPLAN macros, ...)

[http://www.automation.siemens.com/bilddb/cax\\_de.aspx?mlfb=3RV2411-1CA15&lang=en](http://www.automation.siemens.com/bilddb/cax_de.aspx?mlfb=3RV2411-1CA15&lang=en)

Characteristic: Tripping characteristics, I<sup>2</sup>t, Let-through current

<https://support.industry.siemens.com/cs/ww/en/ps/3RV2411-1CA15/char>

Further characteristics (e.g. electrical endurance, switching frequency)

<http://www.automation.siemens.com/bilddb/index.aspx?view=Search&mlfb=3RV2411-1CA15&objecttype=14&gridview=view1>

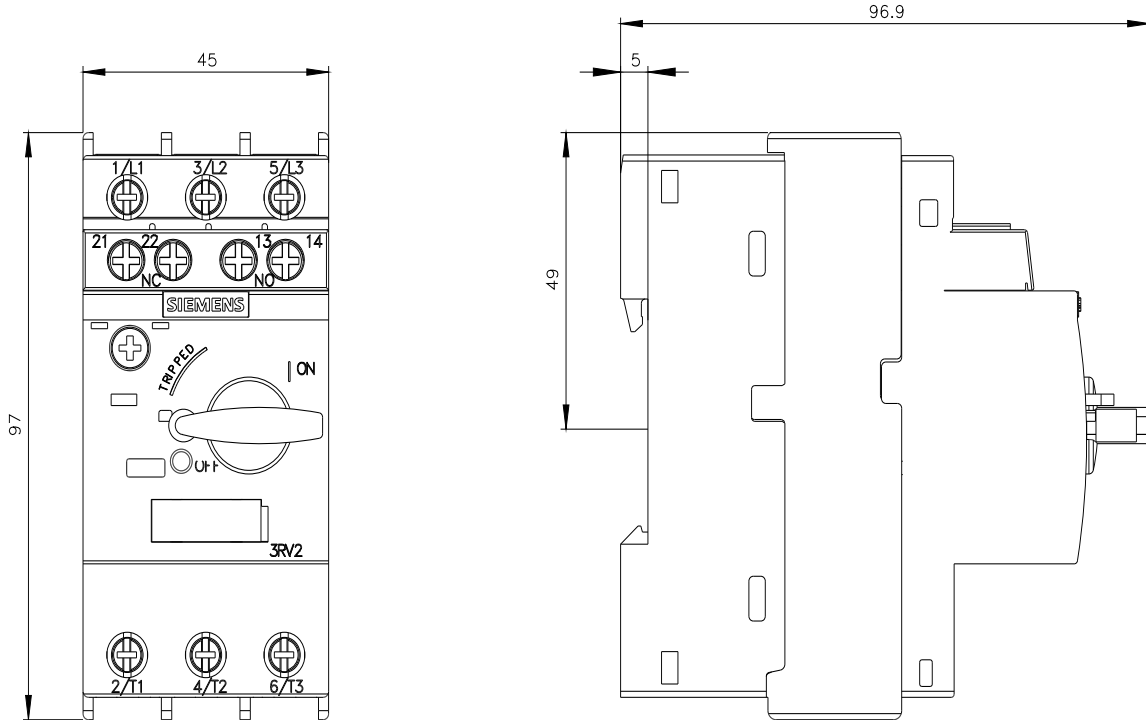

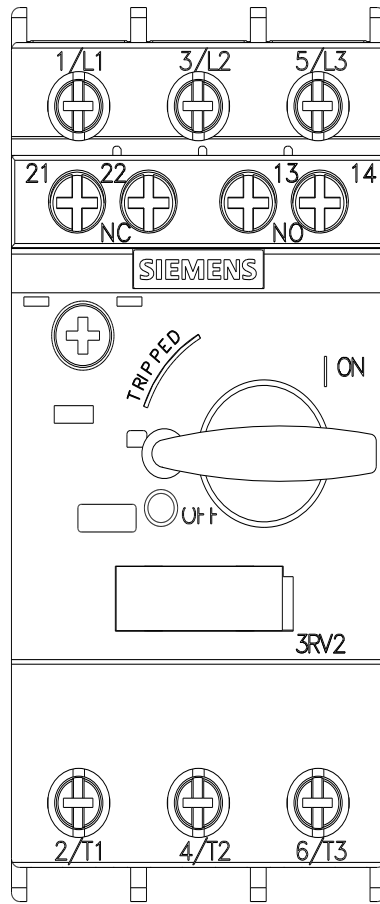

last modified:

11/21/2022