



Selector switch, illuminable, 22 mm, round, plastic, white, selector switch, short, 3 switch positions I-O-II, latching, 10:30h/12h/13:30h, with holder, 1 NO, 1 NO, screw terminal

<b>product brand name</b>	SIRIUS ACT
<b>product designation</b>	Selector switches
<b>design of the product</b>	Complete unit
<b>product type designation</b>	3SU1
<b>product line</b>	Plastic, black, 22 mm
<b>manufacturer's article number</b>	
<ul style="list-style-type: none"> <li>• of supplied contact module at position 1</li> <li>• of supplied contact module at position 2</li> <li>• of the supplied holder</li> <li>• of the supplied actuator</li> </ul>	<a href="#">3SU1400-1AA10-1BA0</a> <a href="#">3SU1400-1AA10-1BA0</a> <a href="#">3SU1550-0AA10-0AA0</a> <a href="#">3SU1002-2BL60-0AA0</a>
<b>Enclosure</b>	
<b>number of command points</b>	1
<b>Actuator</b>	
<b>design of the actuating element</b>	Selector, short
<b>principle of operation of the actuating element</b>	latching, 2x45° (10:30 h/12 h/13:30 h)
product extension optional light source	Yes
color of the actuating element	white
<b>material of the actuating element</b>	plastic
<b>shape of the actuating element</b>	round
<b>outer diameter of the actuating element</b>	32.3 mm
<b>number of contact modules</b>	2
<b>number of switching positions</b>	3
<b>actuating angle</b>	
<ul style="list-style-type: none"> <li>• clockwise</li> <li>• anticlockwise</li> </ul>	45° 45°
<b>Front ring</b>	
<b>product component front ring</b>	Yes
<b>design of the front ring</b>	standard
<b>material of the front ring</b>	plastic
<b>color of the front ring</b>	black
<b>Holder</b>	
<b>material of the holder</b>	Plastic
<b>Display</b>	
<b>number of LED modules</b>	0
<b>General technical data</b>	
product function positive opening	No
product component light source	No
<b>insulation voltage rated value</b>	500 V
<b>degree of pollution</b>	3
type of voltage of the operating voltage	AC/DC

<b>surge voltage resistance rated value</b>	6 kV
<b>protection class IP</b>	IP66, IP67, IP69(IP69K)
• of the terminal	IP20
<b>degree of protection NEMA rating</b>	1, 2, 3, 3R, 4, 4X, 12, 13
<b>shock resistance</b>	
• according to IEC 60068-2-27	sinusoidal half-wave 15g / 11 ms
• for railway applications according to EN 61373	Category 1, Class B
<b>vibration resistance</b>	
• according to IEC 60068-2-6	10 ... 500 Hz: 5g
• for railway applications according to EN 61373	Category 1, Class B
<b>operating frequency maximum</b>	1 800 1/h
<b>mechanical service life (operating cycles) typical</b>	1 000 000
electrical endurance (operating cycles) typical	10 000 000
<b>thermal current</b>	10 A
<b>reference code according to IEC 81346-2</b>	S
<b>continuous current of the C characteristic MCB</b>	10 A; for a short-circuit current smaller than 400 A
<b>continuous current of the quick DIAZED fuse link</b>	10 A
<b>continuous current of the DIAZED fuse link gG</b>	10 A
<b>Substance Prohibitance (Date)</b>	10/01/2014
<b>operating voltage</b>	
• at AC	
— at 50 Hz rated value	5 ... 500 V
— at 60 Hz rated value	5 ... 500 V
• at DC rated value	5 ... 500 V
<b>Power Electronics</b>	
<b>contact reliability</b>	One maloperation per 100 million (17 V, 5 mA), one maloperation per 10 million (5 V, 1 mA)
<b>Auxiliary circuit</b>	
<b>design of the contact of auxiliary contacts</b>	Silver alloy
<b>number of NC contacts for auxiliary contacts</b>	0
<b>number of NO contacts for auxiliary contacts</b>	2
<b>Connections/ Terminals</b>	
<b>type of electrical connection</b>	screw-type terminals
• of modules and accessories	Screw-type terminal
<b>type of connectable conductor cross-sections</b>	
• solid with core end processing	2x (0.5 ... 0.75 mm <sup>2</sup> )
• solid without core end processing	2x (1.0 ... 1.5 mm <sup>2</sup> )
• finely stranded with core end processing	2x (0.5 ... 1.5 mm <sup>2</sup> )
• finely stranded without core end processing	2x (1,0 ... 1,5 mm <sup>2</sup> )
• for AWG cables	2x (18 ... 14)
<b>tightening torque of the screws in the bracket</b>	1 ... 1.2 N·m
tightening torque with screw-type terminals	0.8 ... 0.9 N·m
<b>Safety related data</b>	
B10 value with high demand rate according to SN 31920	300 000
<b>proportion of dangerous failures</b>	
• with low demand rate according to SN 31920	20 %
• with high demand rate according to SN 31920	20 %
failure rate [FIT] with low demand rate according to SN 31920	100 FIT
<b>Ambient conditions</b>	
<b>ambient temperature</b>	
• during operation	-25 ... +70 °C
• during storage	-40 ... +80 °C
environmental category during operation according to IEC 60721	3M6, 3S2, 3B2, 3C3, 3K6 (with relative air humidity of 10 ... 95%, no condensation in operation permitted for all devices behind front panel)
<b>Installation/ mounting/ dimensions</b>	
<b>fastening method</b>	
• of modules and accessories	Front plate mounting
<b>height</b>	40 mm
<b>width</b>	32.3 mm
<b>shape of the installation opening</b>	round
<b>mounting diameter</b>	22.3 mm

positive tolerance of installation diameter	0.4 mm
mounting height	28.8 mm
installation width	32.3 mm
installation depth	49.7 mm

### Certificates/ approvals

General Product Approval	Declaration of Conformity
--------------------------	---------------------------



[Confirmation](#)



Declaration of Conformity	Test Certificates	Marine / Shipping
---------------------------	-------------------	-------------------



[Special Test Certificate](#)

[Type Test Certificates/Test Report](#)



Marine / Shipping	other	Environment
-------------------	-------	-------------



[Confirmation](#)

[Environmental Confirmations](#)

### Further information

Siemens has decided to exit the Russian market (see here).

<https://press.siemens.com/global/en/pressrelease/siemens-wind-down-russian-business>

Siemens is working on the renewal of the current EAC certificates.

Please contact your local Siemens office on the status of validity of the EAC certification if you intend to import or offer to supply these products to an EAC relevant market (other than the sanctioned EAEU member states Russia or Belarus).

Information on the packaging

<https://support.industry.siemens.com/cs/ww/en/view/109813875>

Information- and Downloadcenter (Catalogs, Brochures,...)

<https://www.siemens.com/ic10>

Industry Mall (Online ordering system)

<https://mall.industry.siemens.com/mall/en/en/Catalog/product?mlfb=3SU1100-2BL60-1NA0>

Cax online generator

<http://support.automation.siemens.com/WW/CAXorder/default.aspx?lang=en&mlfb=3SU1100-2BL60-1NA0>

Service&Support (Manuals, Certificates, Characteristics, FAQs,...)

<https://support.industry.siemens.com/cs/ww/en/ps/3SU1100-2BL60-1NA0>

Image database (product images, 2D dimension drawings, 3D models, device circuit diagrams, EPLAN macros, ...)

[http://www.automation.siemens.com/bilddb/cax\\_de.aspx?mlfb=3SU1100-2BL60-1NA0&lang=en](http://www.automation.siemens.com/bilddb/cax_de.aspx?mlfb=3SU1100-2BL60-1NA0&lang=en)

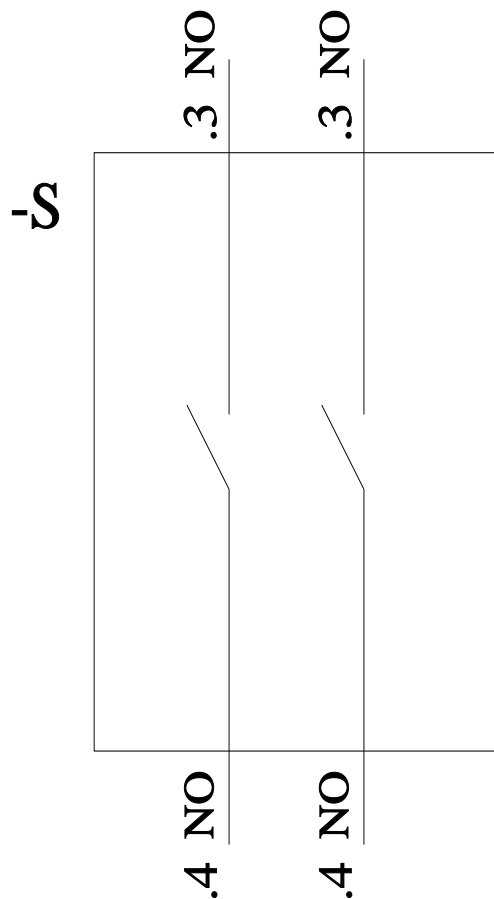
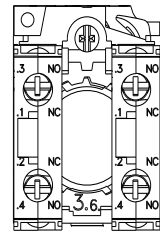
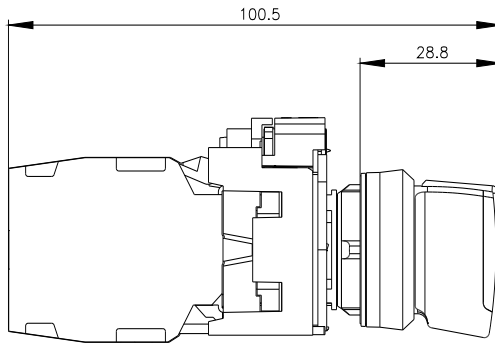
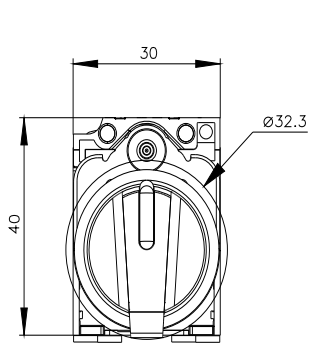

last modified:

1/26/2022

