

Enclosed soft starter, Controller 3RW40261BB14, Std. duty rating 7.5HP @230V, Std. duty current rating 23A Control voltage 110-230 AC/DC Enclosure NEMA type 1, Indoor general purpose use



Figure similar

product brand name	Class 73
design of the product	Enclosed soft starter
special product feature	Control transformer, built-in overload relay and bypass contactor included.
<b>General technical data</b>	
weight [lb]	52 lb
Height x Width x Depth [in]	25 × 18 × 13 in
touch protection against electrical shock	NA for enclosed products
installation altitude [ft] at height above sea level maximum	6560 ft
ambient temperature [°F]	
• during storage	-22 ... +149 °F
• during operation	-4 ... +104 °F
ambient temperature	
• during storage	-30 ... +65 °C
• during operation	-20 ... +40 °C
country of origin	USA
<b>Power and control electronics</b>	
manufacturer's article number of soft starter	3RW40261BB14
number of poles for main current circuit	3
design of power semiconductors (thyristors) for soft starter control	2 controlled phases
operating range factor supply voltage rated value	0.85 ... 1.1
operating range factor of control voltage rated value	0.85 ... 1.1
operating condition for standard duty	Class 10 standard duty (350% of motor FLA for 10 seconds)
operating condition for severe duty	NA
<b>Features and functions</b>	
ramp-up (soft starting)/ramp-down (soft stop)	Yes
starting voltage [%]	40 ... 100 %
stopping voltage [%]	40 ... 100 %
voltage ramp	Yes
ramp-up time	0 ... 20 s
ramp-down time	0 ... 20 s
torque control	No
adjustable current limitation	Yes
creep speed in both directions of rotation	No
pump ramp down	No
integrated bypass contact system	Yes

external isolation contactor	Yes
intrinsic device protection	Yes
overload protection	Yes
trip class	Class 5 / 15 / 20
reset function	Manual, automatic and remote
thermistor motor protection	No
inside-delta circuit	No
breakaway pulse	No
DC braking	No
combined braking	No
motor heating	No
configuration of control input 1	ON / OFF
configuration of control input 2	NA
configuration of control input 3	NA
configuration of control input 4	NA
configuration of relay output 1	ON / RUN
configuration of relay output 2	BYPASSED
configuration of relay output 3	OVERLOAD / FAILURE
configuration of relay output 4	NA
display version	4 LEDs
operating measured value display	No
product extension optional human machine interface module	No
type of communication optional	None
error logbook	No
event list	No
slave pointer function	No
trace function	No
number of parameter sets	1
engineering software (Soft Starter ES)	No
disconnecter functionality	No
<b>Contactor</b>	
size of contactor	NA
<b>Coil</b>	
type of voltage of the control supply voltage	AC/DC
control supply voltage	
• at DC rated value	110 ... 230 V
• at AC at 50 Hz rated value	110 ... 230 V
• at AC at 60 Hz rated value	110 ... 230 V
<b>Enclosure</b>	
degree of protection NEMA rating	1
degree of protection NEMA rating of the enclosure	NEMA Type 1
design of the housing	Indoor general purpose use
type of cooling	None
<b>Mounting/wiring</b>	
mounting position	Vertical
fastening method	Surface mounting and installation
wire length between motor starter and motor maximum	300 m
type of electrical connection for supply voltage line-side	Box lug
type of connectable conductor cross-sections at line-side at AWG cables single or multi-stranded	2/0 ... 14 AWG
temperature of the conductor for supply maximum permissible	75 °C
material of the conductor for supply	CU
type of electrical connection for load-side outgoing feeder	Box lug
tightening torque [lbf·in] for load-side outgoing feeder	18 ... 22 lbf·in
type of connectable conductor cross-sections at AWG cables for load-side outgoing feeder single or multi-stranded	2x (14 ... 10 AWG)

temperature of the conductor for load-side outgoing feeder maximum permissible	75 °C
material of the conductor for load-side outgoing feeder	CU
type of electrical connection for auxiliary and control circuit	screw-type terminals
tightening torque [lbf·in] for auxiliary and control contacts with screw-type terminals	7 ... 10 lbf·in
temperature of the conductor for auxiliary and control contacts maximum permissible	75 °C
material of the conductor for auxiliary and control contacts	CU
<b>Short-circuit current rating</b>	
design of the fuse link for short-circuit protection of the main circuit required	10kA@600V (Class H or K); 100kA@600V (Class R or J)
design of the short-circuit trip	Thermal magnetic circuit breaker
breaking capacity maximum short-circuit current (Icu)	
• at 240 V	42 kA
• at 480 V	42 kA
• at 600 V	0 kA
certificate of suitability	NEMA ICS 2; UL 508A

#### Further information

**Industrial Controls - Product Overview (Catalogs, Brochures,...)**

[www.usa.siemens.com/iccatalog](http://www.usa.siemens.com/iccatalog)

**Industry Mall (Online ordering system)**

<https://mall.industry.siemens.com/mall/en/us/Catalog/product?mlfb=US2:73BR32BFA>

**Service&Support (Manuals, Certificates, Characteristics, FAQs,...)**

<https://support.industry.siemens.com/cs/US/en/ps/US2:73BR32BFA>

**Image database (product images, 2D dimension drawings, 3D models, device circuit diagrams, EPLAN macros, ...)**

[http://www.automation.siemens.com/bilddb/cax\\_de.aspx?mlfb=US2:73BR32BFA&lang=en](http://www.automation.siemens.com/bilddb/cax_de.aspx?mlfb=US2:73BR32BFA&lang=en)

**Certificates/approvals**

<https://support.industry.siemens.com/cs/US/en/ps/US2:73BR32BFA/certificate>

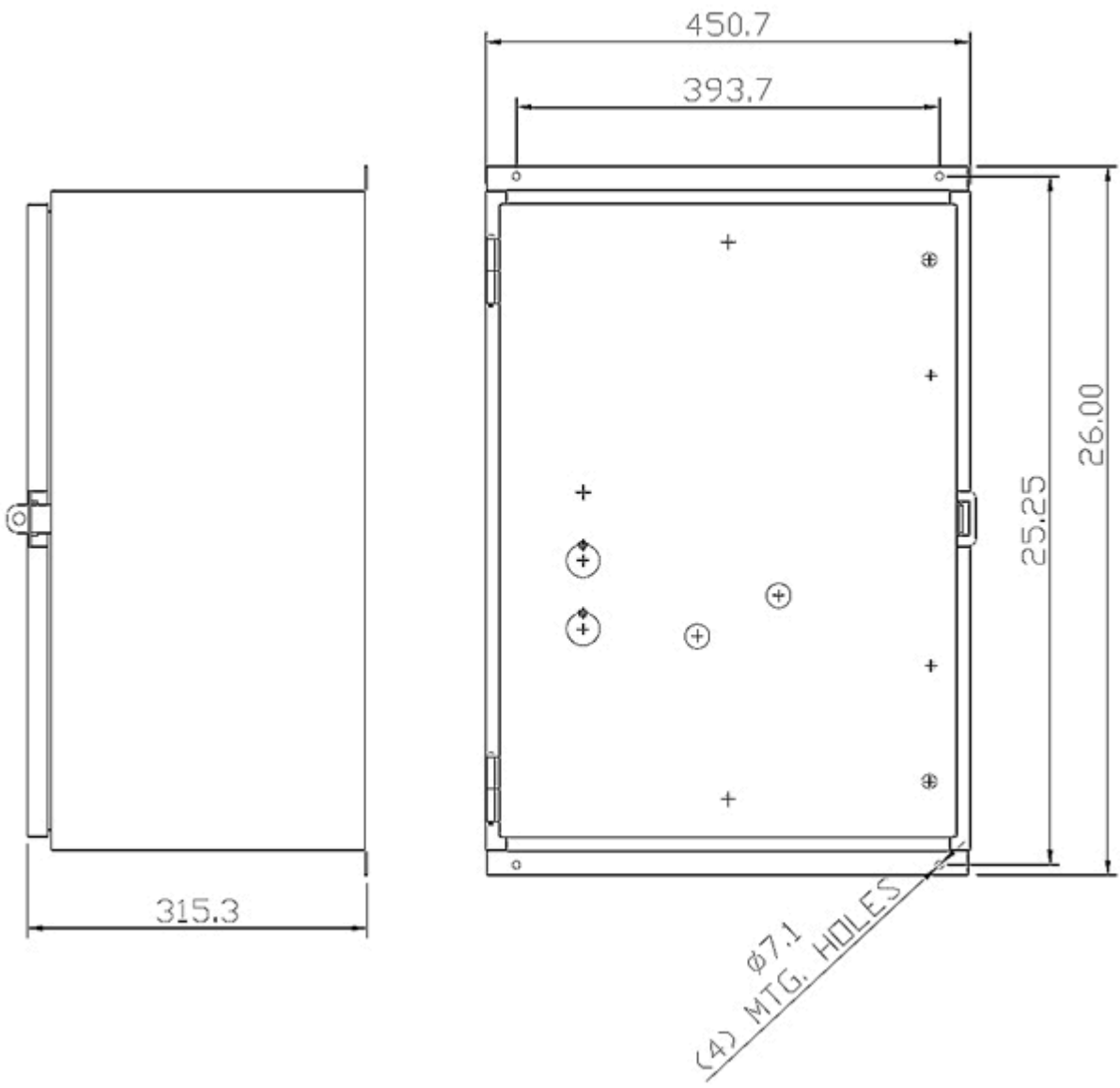

3RW40 NON-OMID ELEMENTARY DIAGRAM

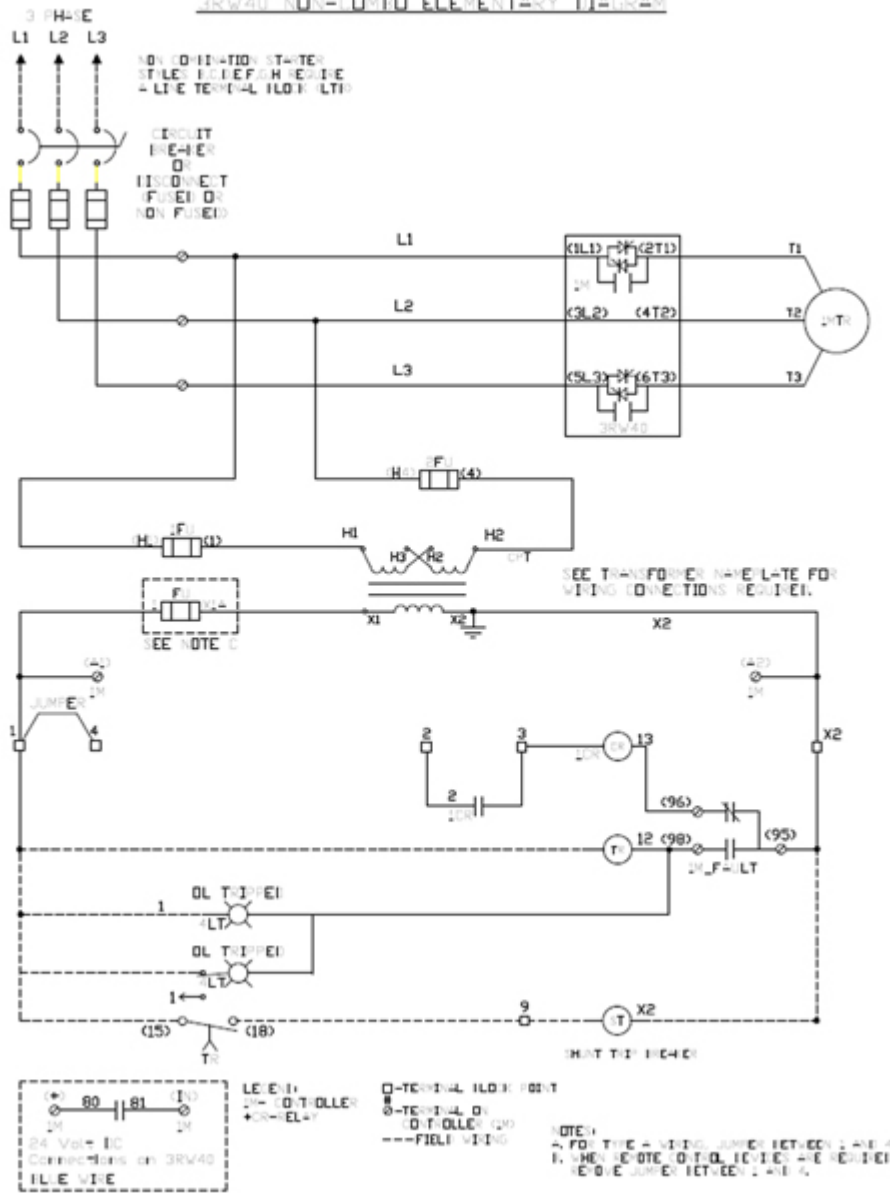

last modified:

3/26/2020