



Figure similar

Duplex starter W/O alternator, Size 1, Three phase full voltage, Solid-state overload relay, OLRelay amp range 10-40a, 110V 50HZ / 120V 60HZ coil, Combination type, Two 30A disconnect switches, Enclosure NEMA type 12, Dust/drip proof for indoors

product brand name	Class 84
design of the product	Duplex controller with two non-fusible disconnect switches without alternator
special product feature	ESP200 overload relay
<b>General technical data</b>	
weight [lb]	70 lb
Height x Width x Depth [in]	34 × 25 × 8 in
touch protection against electrical shock	NA for enclosed products
installation altitude [ft] at height above sea level maximum	6560 ft
ambient temperature [°F]	
• during storage	-22 ... +149 °F
• during operation	-4 ... +104 °F
ambient temperature	
• during storage	-30 ... +65 °C
• during operation	-20 ... +40 °C
country of origin	USA
<b>Horsepower ratings</b>	
yielded mechanical performance [hp] for 3-phase AC motor	
• at 200/208 V rated value	7.5 hp
• at 220/230 V rated value	7.5 hp
• at 460/480 V rated value	0 hp
• at 575/600 V rated value	0 hp
<b>Contactors</b>	
size of contactor	NEMA controller size 1
number of NO contacts for main contacts	3
operating voltage for main current circuit at AC at 60 Hz maximum	600 V
operational current at AC at 600 V rated value	27 A
mechanical service life (switching cycles) of the main contacts typical	10000000
<b>Auxiliary contact</b>	
number of NC contacts at contactor for auxiliary contacts	0
number of NO contacts at contactor for auxiliary contacts	1
number of total auxiliary contacts maximum	8
contact rating of auxiliary contacts of contactor according to UL	10A@600VAC (A600), 5A@600VDC (P600)

Coil	
type of voltage of the control supply voltage	AC
control supply voltage	
<ul style="list-style-type: none"> <li>at DC rated value</li> <li>at AC at 50 Hz rated value</li> <li>at AC at 60 Hz rated value</li> </ul>	0 ... 0 V 110 ... 110 V 120 ... 120 V
holding power at AC minimum	8.6 W
apparent pick-up power of magnet coil at AC	218 V·A
apparent holding power of magnet coil at AC	25 V·A
operating range factor control supply voltage rated value of magnet coil	0.85 ... 1.1
percental drop-out voltage of magnet coil related to the input voltage	50 %
switch ON delay time	19 ... 29 ms
OFF delay time	10 ... 24 ms
Overload relay	
product function	
<ul style="list-style-type: none"> <li>overload protection</li> <li>phase failure detection</li> <li>asymmetry detection</li> <li>ground fault detection</li> <li>test function</li> <li>external reset</li> </ul>	Yes Yes Yes Yes Yes Yes
reset function	Manual, automatic and remote
trip class	Class 5 / 10 / 20 (factory set) / 30
adjustable current response value current of the current-dependent overload release	10 ... 40 A
tripping time at phase-loss maximum	3 s
relative repeat accuracy	1 %
number of NC contacts of auxiliary contacts of overload relay	1
number of NO contacts of auxiliary contacts of overload relay	1
operational current of auxiliary contacts of overload relay	
<ul style="list-style-type: none"> <li>at AC at 600 V</li> <li>at DC at 250 V</li> </ul>	5 A 1 A
contact rating of auxiliary contacts of overload relay according to UL	5A@600VAC (B600), 1A@250VDC (R300)
insulation voltage	
<ul style="list-style-type: none"> <li>with single-phase operation at AC rated value</li> <li>with multi-phase operation at AC rated value</li> </ul>	600 V 300 V
Disconnect Switch	
response value of switch disconnecter	30A / 600V
design of fuse holder	non-fusible
operating class of the fuse link	non-fusible
Enclosure	
degree of protection NEMA rating of the enclosure	NEMA Type 12
design of the housing	Dust tight and drip proof for indoors
Mounting/wiring	
mounting position	Vertical
fastening method	Surface mounting and installation
type of electrical connection for supply voltage line-side	Box lug
tightening torque [lbf·in] for supply	35 ... 35 lbf·in
type of connectable conductor cross-sections at line-side at AWG cables single or multi-stranded	1x (14 ... 2 AWG)
temperature of the conductor for supply maximum permissible	75 °C
material of the conductor for supply	AL or CU
type of electrical connection for load-side outgoing feeder	Screw-type terminals
tightening torque [lbf·in] for load-side outgoing feeder	35 ... 35 lbf·in

type of connectable conductor cross-sections at AWG cables for load-side outgoing feeder single or multi-stranded	1x (14 ... 2 AWG)
temperature of the conductor for load-side outgoing feeder maximum permissible	75 °C
material of the conductor for load-side outgoing feeder	AL or CU
type of electrical connection of magnet coil	Screw-type terminals
tightening torque [lbf·in] at magnet coil	5 ... 12 lbf·in
type of connectable conductor cross-sections of magnet coil at AWG cables single or multi-stranded	2x (16 ... 12 AWG)
temperature of the conductor at magnet coil maximum permissible	75 °C
material of the conductor at magnet coil	CU
type of electrical connection at contactor for auxiliary contacts	Screw-type terminals
tightening torque [lbf·in] at contactor for auxiliary contacts	10 ... 15 lbf·in
type of connectable conductor cross-sections at contactor at AWG cables for auxiliary contacts single or multi-stranded	1x (12 AWG), 2x (16 ... 14 AWG), 2x (18 ... 16 AWG)
temperature of the conductor at contactor for auxiliary contacts maximum permissible	75 °C
material of the conductor at contactor for auxiliary contacts	CU
type of electrical connection at overload relay for auxiliary contacts	Screw-type terminals
tightening torque [lbf·in] at overload relay for auxiliary contacts	7 ... 10 lbf·in
type of connectable conductor cross-sections at overload relay at AWG cables for auxiliary contacts single or multi-stranded	2x (20 ... 14 AWG)
temperature of the conductor at overload relay for auxiliary contacts maximum permissible	75 °C
material of the conductor at overload relay for auxiliary contacts	CU
<b>Short-circuit current rating</b>	
design of the fuse link for short-circuit protection of the main circuit required	10kA@600V (Class H or K); 100kA@600V (Class R or J)
certificate of suitability	NEMA ICS 2; UL 508; CSA 22.2, No.14

#### Further information

**Industrial Controls - Product Overview (Catalogs, Brochures,...)**

[www.usa.siemens.com/iccatalog](http://www.usa.siemens.com/iccatalog)

**Industry Mall (Online ordering system)**

<https://mall.industry.siemens.com/mall/en/us/Catalog/product?mlfb=US2:84DUE950DF>

**Service&Support (Manuals, Certificates, Characteristics, FAQs,...)**

<https://support.industry.siemens.com/cs/US/en/ps/US2:84DUE950DF>

**Image database (product images, 2D dimension drawings, 3D models, device circuit diagrams, EPLAN macros, ...)**

[http://www.automation.siemens.com/bilddb/cax\\_de.aspx?mlfb=US2:84DUE950DF&lang=en](http://www.automation.siemens.com/bilddb/cax_de.aspx?mlfb=US2:84DUE950DF&lang=en)

**Certificates/approvals**

<https://support.industry.siemens.com/cs/US/en/ps/US2:84DUE950DF/certificate>

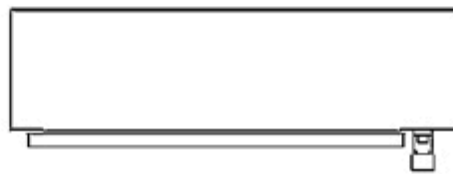
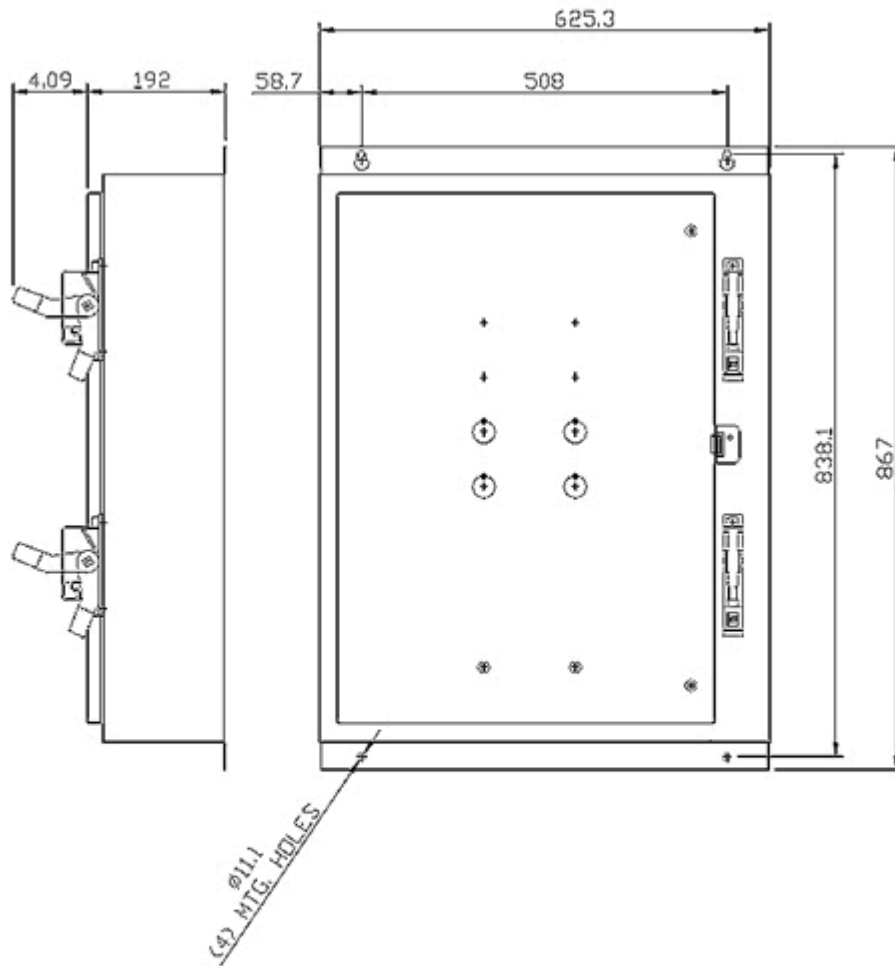

# SCHEMATIC DIAGRAM

Class 83 & 84 Duplex W/Manual Alternation Size 0-4

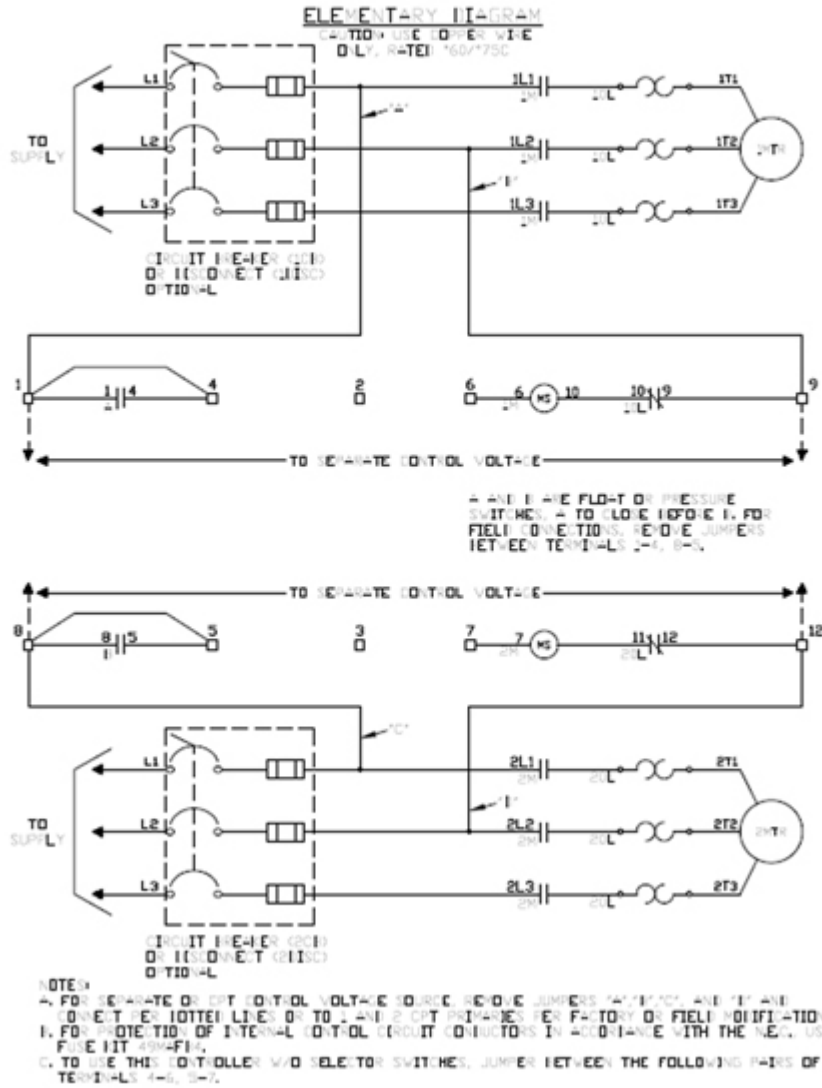

last modified:

4/7/2020