

# SIEMENS

SIMATIC Ident

RFID systems  
RF180C communication module



Operating Instructions

<u>Introduction</u>	<b>1</b>
<u>Description</u>	<b>2</b>
<u>Installation</u>	<b>3</b>
<u>Connecting</u>	<b>4</b>
<u>Parameterization</u>	<b>5</b>
<u>Maintenance and service</u>	<b>6</b>
<u>Diagnostics</u>	<b>7</b>
<u>Technical data</u>	<b>8</b>
<u>Dimension drawings</u>	<b>9</b>
<u>Connecting cable to the reader</u>	<b>10</b>
<u>Ordering data</u>	<b>11</b>
<u>Service &amp; Support</u>	<b>12</b>

## Legal information

### Warning notice system

This manual contains notices you have to observe in order to ensure your personal safety, as well as to prevent damage to property. The notices referring to your personal safety are highlighted in the manual by a safety alert symbol, notices referring only to property damage have no safety alert symbol. These notices shown below are graded according to the degree of danger.

 <b>DANGER</b>
indicates that death or severe personal injury <b>will</b> result if proper precautions are not taken.
 <b>WARNING</b>
indicates that death or severe personal injury <b>may</b> result if proper precautions are not taken.
 <b>CAUTION</b>
indicates that minor personal injury can result if proper precautions are not taken.
<b>NOTICE</b>
indicates that property damage can result if proper precautions are not taken.

If more than one degree of danger is present, the warning notice representing the highest degree of danger will be used. A notice warning of injury to persons with a safety alert symbol may also include a warning relating to property damage.

### Qualified Personnel

The product/system described in this documentation may be operated only by **personnel qualified** for the specific task in accordance with the relevant documentation, in particular its warning notices and safety instructions. Qualified personnel are those who, based on their training and experience, are capable of identifying risks and avoiding potential hazards when working with these products/systems.

### Proper use of Siemens products

Note the following:

 <b>WARNING</b>
Siemens products may only be used for the applications described in the catalog and in the relevant technical documentation. If products and components from other manufacturers are used, these must be recommended or approved by Siemens. Proper transport, storage, installation, assembly, commissioning, operation and maintenance are required to ensure that the products operate safely and without any problems. The permissible ambient conditions must be complied with. The information in the relevant documentation must be observed.

### Trademarks

All names identified by ® are registered trademarks of Siemens AG. The remaining trademarks in this publication may be trademarks whose use by third parties for their own purposes could violate the rights of the owner.

### Disclaimer of Liability

We have reviewed the contents of this publication to ensure consistency with the hardware and software described. Since variance cannot be precluded entirely, we cannot guarantee full consistency. However, the information in this publication is reviewed regularly and any necessary corrections are included in subsequent editions.

# Table of contents

<b>1</b>	<b>Introduction</b> .....	<b>5</b>
<b>2</b>	<b>Description</b> .....	<b>7</b>
<b>3</b>	<b>Installation</b> .....	<b>11</b>
3.1	Mounting position, mounting dimensions.....	11
3.2	Mounting the I/O module.....	12
3.3	Mounting the connection block .....	13
3.4	Replacing labels.....	15
3.5	Disassembling the RF180C .....	16
<b>4</b>	<b>Connecting</b> .....	<b>17</b>
4.1	Wiring connection block M12, 7/8".....	19
4.2	Wiring of the push-pull connection block .....	23
4.3	Loop-through connection of PROFINET IO and supply voltage.....	26
4.4	Wiring an RF180C to a controller with RJ45 connector.....	28
4.5	Connecting the RF180C to functional ground (PE) .....	28
<b>5</b>	<b>Parameterization</b> .....	<b>31</b>
5.1	PROFINET IO configuration .....	31
5.2	Assigning device names to the I/O device.....	32
5.3	Configuration parameters of the RF180C.....	36
5.4	Input parameters for RF180C .....	37
5.5	Command table of the RF180C .....	40
<b>6</b>	<b>Maintenance and service</b> .....	<b>43</b>
6.1	Replacing the RF180C communication module .....	43
6.2	Firmware update .....	45
6.3	Reset to factory settings .....	48
<b>7</b>	<b>Diagnostics</b> .....	<b>49</b>
7.1	Diagnosis using LEDs.....	49
7.2	Parameterization of the diagnostics.....	51
7.3	Structure of the diagnostic data .....	52
<b>8</b>	<b>Technical data</b> .....	<b>53</b>
<b>9</b>	<b>Dimension drawings</b> .....	<b>57</b>
9.1	Dimension drawing for RF180C with fixing holes .....	57

<b>10</b>	<b>Connecting cable to the reader</b> .....	<b>59</b>
10.1	Routing of standard cables .....	59
10.2	Self-assembled cable .....	62
<b>11</b>	<b>Ordering data</b> .....	<b>63</b>
<b>12</b>	<b>Service &amp; Support</b> .....	<b>65</b>

# Introduction

## Purpose of these operating instructions

The information provided in these Operating Instructions enables you to operate the RF180C communication module on a PROFINET IO controller.

## Basic knowledge required

These operating instructions assume general knowledge of automation engineering and identification systems.

## Scope of the manual

The operating instructions apply to the RF180C communication module.

## Position in the information landscape

- In addition to these operating instructions, you require the operating instructions for the controller used.
- If you are using a SIMATIC S7, you will find information on programming the module as well as a complete error description in the description of the function blocks FB 45, FB 55 and the RFID standard profile.
- The manual of the relevant RFID family contains information on the readers to be connected.
- Special information on setting parameters for the RF620R/RF630R readers in conjunction with the RF180C communications module can be found in the "Configuration manual RF620R/RF630R (<http://support.automation.siemens.com/WW/view/en/33287195>)".

## Guide

These operating instructions describe the hardware of the RF180C communication module. They comprise introductory chapters and reference chapters (e.g. technical data).

The operating instructions include the following subject areas:

- Connection of the RF180C communication module
- Parameterization of the RF180C communication module
- Diagnostics information
- Display elements of the RF180C communication module
- Information on repair and maintenance (e.g. firmware update)
- Technical data as well as dimension drawings of the RF180C communication module
- Ordering data

## Recycling and disposal

- Due to its non-toxic equipment, the RF180C communication module can be recycled.
- Contact a certified electronic-waste disposal company to recycle and dispose of your old equipment in an environment-friendly manner.

## Description

### Area of application

The RF180C communication module is a module that can be used on any controller for operating RFID components over PROFINET IO.

#### RF180C communication module

With M12 connection block (7/8")

With push-pull connection block



When operating the RF180C on a SIMATIC S7, a user-friendly function block is made available to the user (FB 45/FB 55). FB 55 can be used for single tag applications and multitag applications; FB 45, however, can only be used for single tag applications. When using it on other controllers, please follow the appropriate instructions for parameterization and integration in the system.

The following RFID readers and code readers can be operated with the RF180C:

- RF200
- RF300 (standard addressing)
- RF600 (RF620R and RF630R)
- MOBY D
- MOBY U (standard addressing)
- MOBY E
- MOBY I (standard addressing)

- MV400 code readers
- RFID standard profile
- RF300 Filehandler

You will find further information on the various RFID and code readers on the Internet on the "Product Support (<http://support.automation.siemens.com/WW/view/en/43532183>)" page.

## Features

Up to two readers can be operated on the RF180C at the same time. You can send a command to 2 readers simultaneously (FB 45/FB 55 or RFID standard profile when operating on a SIMATIC S7).

The transponder data is accessed using the physical addressing of the transponder. In SIMATIC S7, FB 45/FB 55 or RFID standard profile are available for this purpose. FB 45 / FB 55 / file handle mode provides you with a simple-to-use interface with extensive commands (processing one complete transponder with one command; command linking; S7 data structures via UDTs).

## Other features

- Degree of protection IP67
- System integration with M12, 7/8" concept or with push-pull concept
- Standardized PROFINET IO user interface for identification technology with RFID standard profile
- Firmware update
- Parameterizable device-specific diagnostics data
- Support of I&M functionality

A mechanism for reading out information via the module and saving system information such as function, installation date, installation location, and comments. The RF180C supports I&M data 0, 1, 2 and 3.

- Routing capability
- IRT Flex
- Topology capability
- LLDP protocol

---

### Note

IRT Top and MRP are not supported by today's valid version of the RF180C.

---



Design

The RF180C has the same enclosure as the RFID communication module ASM 456 for PROFIBUS.

For connecting to PROFINET IO, the RF180C communication module features a connection block in one of the following designs:

- M12 connection block design (7/8")
- Push-pull connection block design, RJ-45

The following figure shows the basic design of the RF180C.

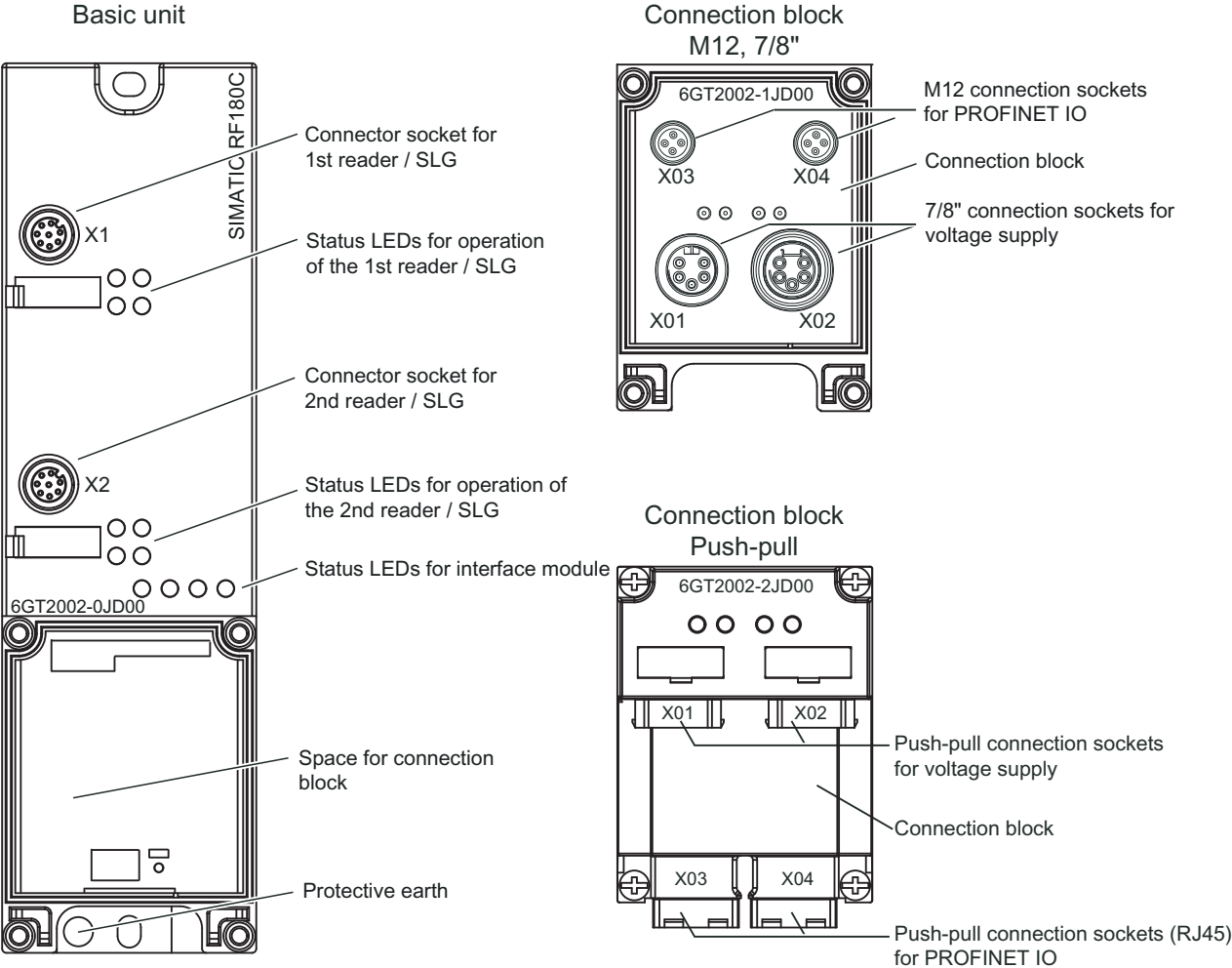

Figure 2-1 Basic design of the RF180C

### Potential

Ungrounded installation of the system is possible with the RF180C. The following circuit shows the internal relationships of the reference potentials.

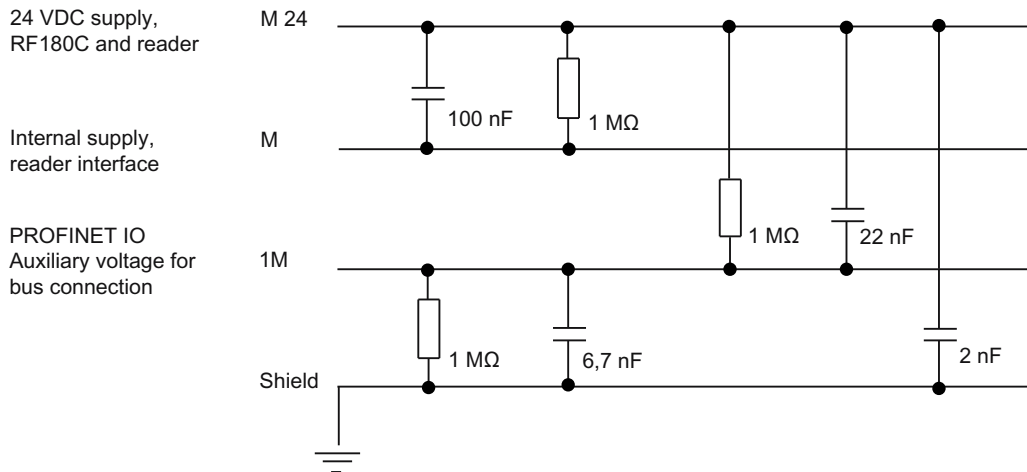

Figure 2-2 Galvanic isolation of RF180C

### Integration

The following figure shows how the RF180C with M12 connection block (7/8") is integrated in an automation system. The push-pull connection block is integrated in the same manner as the M12 connection block (7/8").

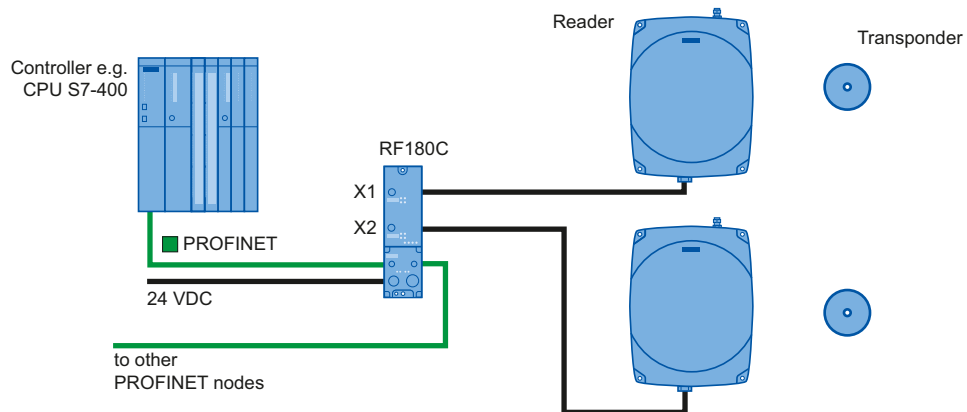

Figure 2-3 RF180C configurator with M12 connection block (7/8")

The RF180C is integrated into the hardware configuration by means of a GSDML file. The RF180C can then be configured using HW Config of the SIMATIC manager or another PROFINET tool. You will find the GSDML file on the "RFID Systems Software & Documentation (<http://support.automation.siemens.com/WW/view/en/65102624>)" DVD.

## Installation

The RF180C communication module is designed for easy assembly.

### 3.1 Mounting position, mounting dimensions

#### Mounting position

There are no restrictions regarding the mounting position for the RF180C.

#### Mounting dimensions and spacing

Table 3- 1 Mounting dimensions of basic module with M12 connection block (7/8", without connector)

Designation	Dimensions
Mounting width	60 mm
Mounting height	210 mm
Mounting depth	54 mm

Table 3- 2 Mounting dimensions of basic module with push-pull connection block (without connector)

Designation	Dimensions
Mounting width	60 mm
Mounting height	216 mm
Mounting depth	100 mm

## 3.2 Mounting the I/O module

### Features

- The base unit is mounted on a stable surface

---

#### Note

##### Functional ground (PE)

If a grounded metal mounting surface is used, the bottom mounting screw of the RF180C module already establishes a reliable grounding connection. This eliminates the need for a separate grounding cable. If you use the fixing screw as grounding connection, the thread of the fixing screw or the contact facing of the fastening nut on the base must be unpainted. This ensures a low-resistance connection.

---

### Requirements

Screws:

Screw type	Description
M5 cylindrical head screw to ISO 1207/ISO 1580 (DIN 84/DIN 85)	The screw should be at least 20 mm long. You will also need washers according to DIN 125.
Cylindrical head screw with M5 hexagonal recessed hole according to DIN 912	

### Required tools

Medium-sized cross-head screwdriver or 8 mm socket wrench.

## Procedure

Fix the base unit onto a level surface using the screws. The base unit must be screwed to the surface (3 Nm tightening torque) at both fixing points (front, top and bottom).

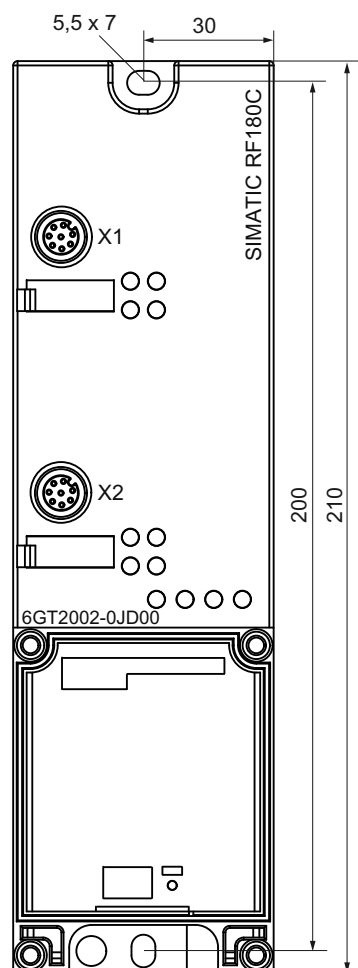

Figure 3-1 Mounting the I/O module

## 3.3 Mounting the connection block

### Features

The connection block connects the RF180C with the PROFINET IO and supplies the base unit with voltage.

### Requirements

The base unit is already mounted

3.3 Mounting the connection block

Required tools

Cross-head screwdriver, medium.

Mounting the connection block

1. Plug the connection block into the base unit
2. Screw the connection block onto the base unit (torque 1 to 1.3 Nm). Tighten the screws evenly, working in cross-wise passes. 4 screws are already located in the connection block (see Figure).

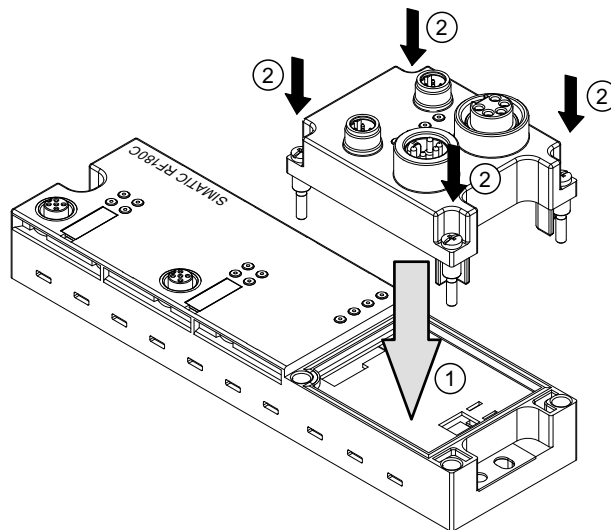

Figure 3-2 Plug the M12 connection block (7/8") onto the base unit and screw it on

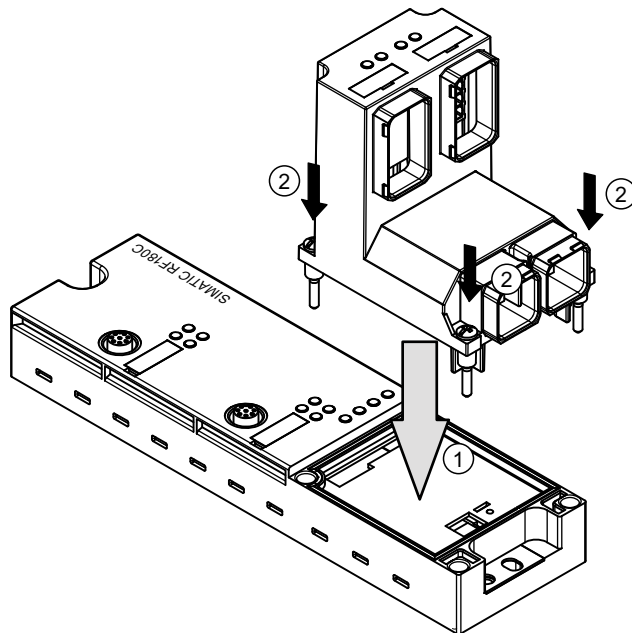

Figure 3-3 Plug the push-pull connection block onto the base unit and screw it on

**NOTICE****Ensuring the degree of protection**

IP65, IP66 or IP67 protection only exists when the connection block is screwed to the base unit and the connectors are plugged in or closed.

## 3.4 Replacing labels

### Features

You can use the labels to mark every channel on the base unit and the connection block. The labeling strips are supplied with clipped on label.

- 2 labels on the base module
- 1 label on M12 connection block (7/8")
- 2 labels on push-pull connection block

### Requirements

If you want to replace the labels, you can reorder them. You will find the order number in the section "Ordering data (Page 63)".

### Required tools

Screwdriver, size 2.5 mm to 4 mm.

### Replacing labels

1. Push the screwdriver into the small opening of the label, and then lever it out.

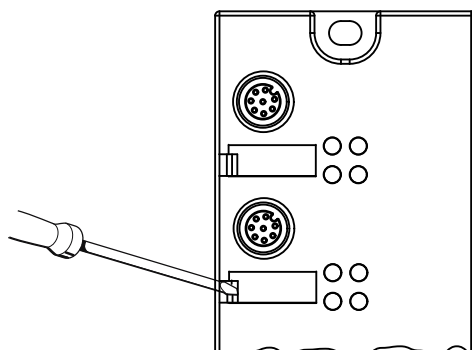

Figure 3-4 Removing labels

2. With your finger push the new label into the holder of the module.

## **3.5 Disassembling the RF180C**

### **Procedure**

The RF180C is wired up and operating.

1. Switch off the supply voltage for the RF180C.
2. Disconnect the wiring on the connection block.
3. Remove the 4 fixing screws from the connection block and pull the connection block off the base unit.
4. Disconnect the wiring on the base unit.
5. Remove the fixing screws from the base unit.

---

### **Note**

Please note the information in the section Loop-through connection of PROFINET IO and supply voltage (Page 26).

---



# Connecting

## Proper use

When connecting non-specified devices to the RF180C, it is possible that the connected device may be destroyed.

## PROFINET IO connection system

Detailed information about connecting the RF180C to PROFINET IO can be found in the "SIMATIC PROFINET system description (<http://support.automation.siemens.com/WW/view/en/19292127/0/en>)".

### CAUTION

#### **Power supply for devices with PROFINET interfaces**

Modules with PROFINET interfaces may only be operated in LANs (Local Area Networks) in which all connected nodes are equipped with SELV/PELV power supplies or protection systems of equal quality.

A data transfer terminal (modem, for example) is required to access the WAN (Wide Area Network) in order to ensure compliance with this safety standard.

The power supply must provide the current required (max. 1.5 A) during brief power failures of  $\leq 20$  ms.

All supply and signal voltages must be safety extra low voltage (SELV/PELV according to EN 60950).

24 VDC power supply: safe (electrical) isolation of extra-low voltage (SELV/PELV according to EN 60950).

### NOTICE

#### **Do not connect the device directly to the telephone network**

The device must **not** be connected to the public telephone network without a hub / switch because the voltage intervals are designed for 500 V.

### PROFINET IO installation techniques

PROFINET IO communication can be set up as a bus a "BUS" or "STAR". Please note the information in the section "Loop-through connection of PROFINET IO and supply voltage (Page 26)".

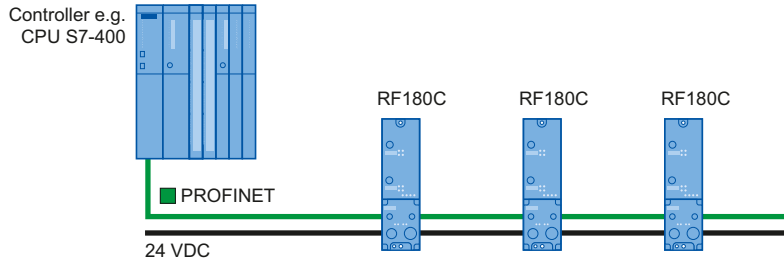

Figure 4-1 RF180C with "BUS" setup

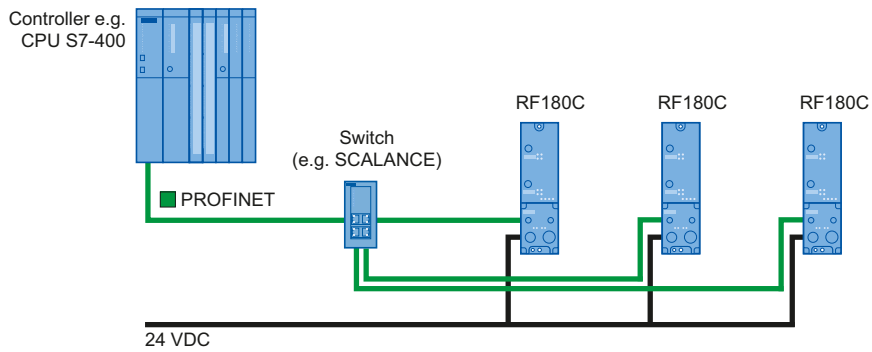

Figure 4-2 RF180C with "STAR" setup

## Reader connector system

One reader always occupies one M12 socket on the RF180C. A pre-assembled cable therefore permits the optimum and easy connection of the reader. The connection cable is 2 m long in the standard version.

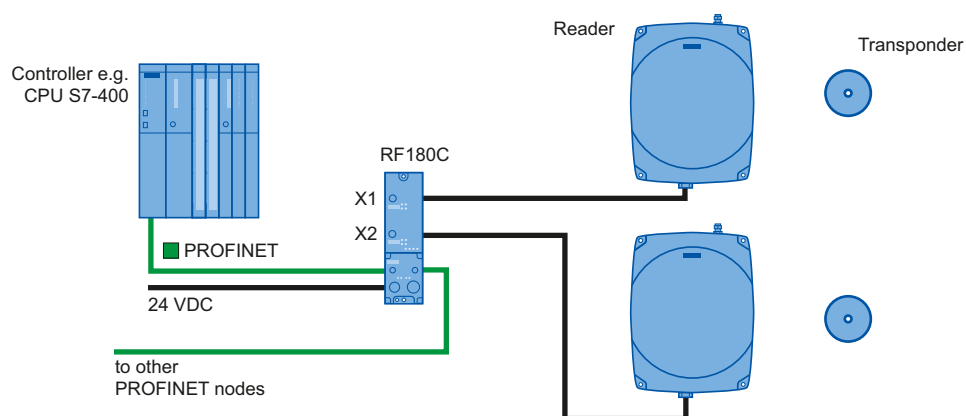

Figure 4-3 Overview of wiring

## 4.1 Wiring connection block M12, 7/8"

### Features

- Connect the supply voltages and PROFINET IO to connection block M12, 7/8":
  - M12 connection in D coding: PROFINET IO
  - 7/8" connection: Supply voltages
- You can loop the supply voltages and PROFINET IO through via the second M12 or 7/8" round socket.

### Requirements

- Wire connection block M12, 7/8" when the supply voltage is switched off.

### Required tools

Stripping tool, screwdriver for wiring the M12 and/or 7/8" connector if you are not using a pre-assembled cable.

4.1 Wiring connection block M12, 7/8"

**Accessories required**

- Pre-assembled cable with connector
- If you are not using a pre-assembled cable:
  - M12: 4-wire Ethernet cable (twisted pair), shielded and M12 connector 4-pin, D coded (see table "Pin assignment M12 connector 4-pin, D coded (PROFINET IO)")
  - 7/8": 5-wire cable and 7/8" connector (see table "Pin assignment for 7/8" connector (supply voltages)")
- For order numbers, refer to the section "Ordering data (Page 63)".

**Wiring M12, 7/8" connector**

The tables below contain the pin assignment for the M12 and 7/8" connectors:

Table 4- 1 Pin assignment for M12 connector, 4-pole, D coding (PROFINET IO)

Pin	Assignment	View of M12 connector, 4-pole, D coding (wiring side)
1	Data line TxP	 <p>Infeed and loop-through of PROFINET IO X3, X4</p> <p>Ethernet cable (twisted pair)</p> <p>Any connector can be used for infeed and looping through.</p>
2	Data line RxP	
3	Data line TxN	
4	Data line RxN	

Table 4- 2 Pin assignment for 7/8" connector (supply voltages)

Pin	Assignment	View of 7/8" connector (wiring side)
1	Load voltage ground (2M)	
2	Ground for electronic / encoder supply (1M)	
3	Functional ground (PE)	
4	Electronics/encoder supply (1L+) (power supply for RF180C and reader)	
5	Load voltage supply (2L+) (unused on RF180C)	

**Note**

When connecting up the supply voltage, we recommend the cable specified in the section "Ordering data (Page 63)" (cable 5 x 1.5 mm<sup>2</sup> pre-assembled with 7/8" connectors).

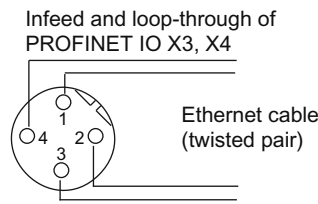
If you want to assemble the cable yourself, then the conductor cross-section should be 1.5 mm<sup>2</sup>.

**Connecting M12, 7/8" connectors**

1. Press the connector (M12 or 7/8") into the relevant round socket on the connection block. Ensure that the correct stop is provided between the connector and bush (groove and spring).
2. Use the knurled locking ring to secure the connector.

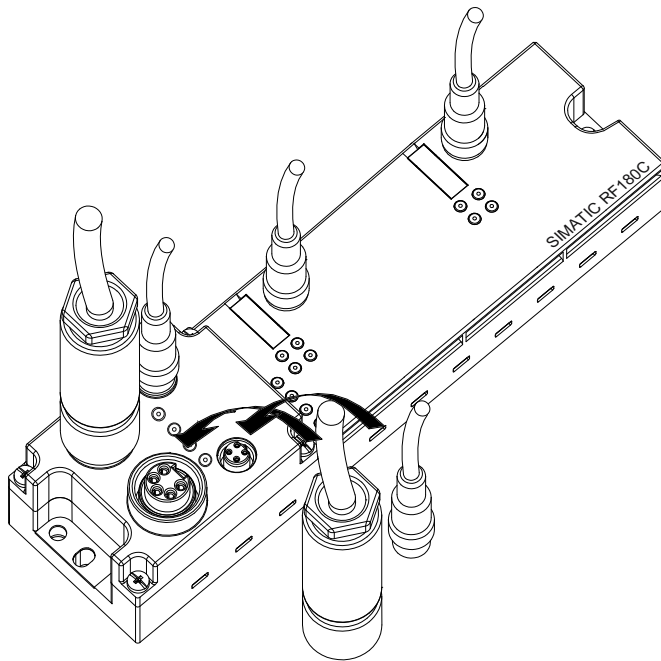

Figure 4-4 Connecting M12, 7/8" connectors

**NOTICE**

**Ensuring the degree of protection**

Always close all unused sockets using M12 or 7/8" sealing caps in order to ensure degree of protection IP65, IP66 or IP67. For order numbers, refer to the section "Ordering data (Page 63)".

## 4.2 Wiring of the push-pull connection block

### Features

- Connect the power supplies and PROFINET IO to the push-pull connection block:
  - Push-pull connection (RJ-45), D-coded: PROFINET IO
  - Push-pull connection: Supply voltages
- You can loop through the supply voltages and the PROFINET IO via the second push-pull connection.

### Requirements

- Wire the push-pull connection block with the supply voltage switched off.

### Required tools

- Screwdriver
- Stripping tool for wiring the push-pull cable connector if you assemble your own cables.

### Accessories required

- Pre-fabricated cables with push-pull cable connector for 1L+/2L+ and RJ-45. The cables are available in various lengths from appropriate manufacturers.
- If you assemble your own cables:
  - 5-core cable and push-pull cable connector for 1L+/2L+
  - 4-core, shielded cable (bus cable) and push-pull cable connector for RJ-45

---

#### Note

Refer to the manufacturer's documentation if you assemble the cables with the push-pull cable connectors.

---

**Wiring of push-pull connectors**

The tables below contain the pin assignment for the push-pull connectors:

Table 4- 3 Pin assignment of push-pull cable connectors (RJ-45)

View of push-pull cable connectors (RJ-45)	Terminal	Assignment
	<b>X03 PN1 for feeding of PROFINET</b> <b>X04 PN2 for looping through of PROFINET</b>	
	1	Receive Data+ RD
	2	Receive Data- RD_N
	3	Transmit Data+ TD
	4	Ground GND (RJ-45)
	5	Ground GND (RJ-45)
	6	Transmit Data- TD_N
	7	Ground GND (RJ-45)
8	Ground GND (RJ-45)	

Table 4- 4 Pin assignment of push-pull cable connectors (1L+ and 2L+ supply voltages)

View of push-pull cable connectors (1L+ and 2L+ supply voltages)	Terminal	Assignment
	<b>X01 DC 24 V for infeed</b> <b>X02 24 VDC for looping through</b>	
	1	Electronic/encoder supply 1L+ground
	2	Ground for electronic/encoder supply 1M
	3	2L+ load voltage supply
	4	Ground for load voltage supply 2M
5	Functional ground (PE)	



**Note**

When connecting the power supply, we recommend the cable specified in the section "Ordering data (Page 63)" (cable 5 x 1.5 mm<sup>2</sup> pre-assembled with push-pull connectors).

If you want to assemble the cable yourself, then the conductor cross-section should be 1.5 mm<sup>2</sup>.

**A cable cross-section of 2.5 mm<sup>2</sup> is mandatory for an amperage > 8 A.**

**Connecting push-pull cable connectors**

Plug the push-pull cable connectors for 1L+/2L+ and RJ-45 into the associated sockets (see figure below). Ensure that the locking mechanism between the connector and socket is properly applied. The connectors must engage.

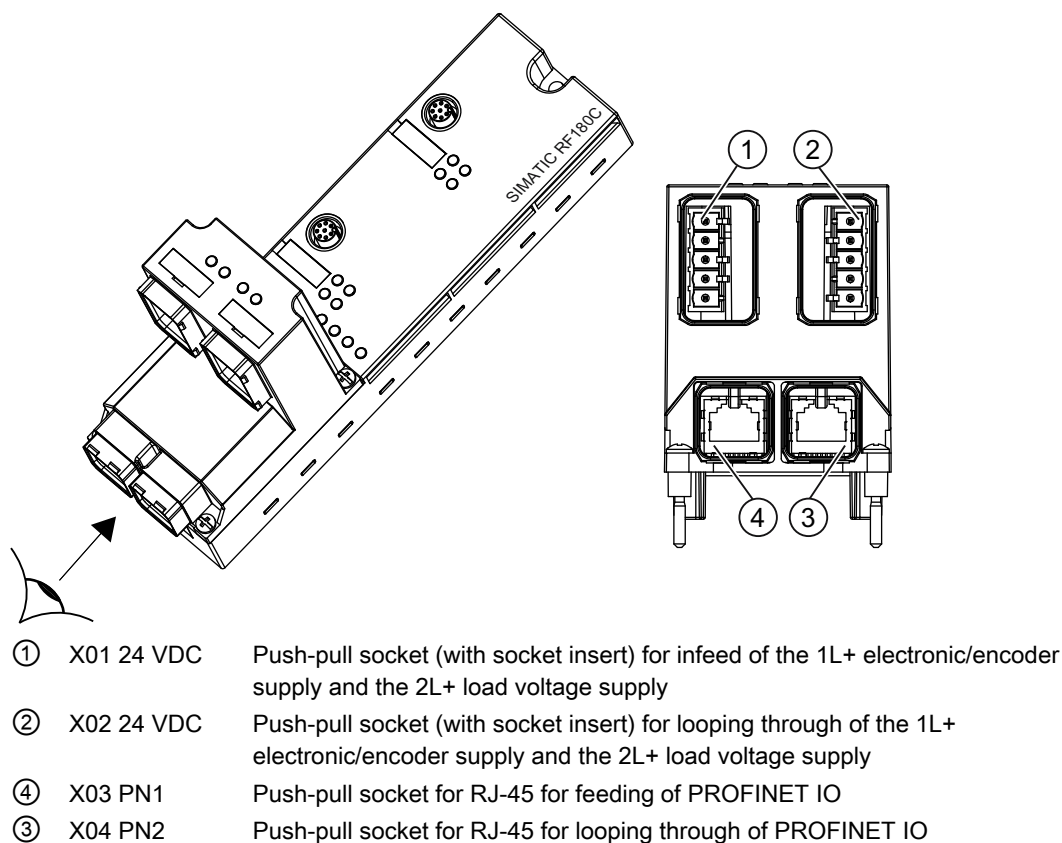

Figure 4-5 Connecting push-pull cable connectors

<b>NOTICE</b>
<b>Ensuring the degree of protection</b>
Cover all unused push-pull sockets with caps in order to ensure degree of protection IP65, IP66, or IP67. For order numbers, refer to the section "Ordering data (Page 63)".

### 4.3 Loop-through connection of PROFINET IO and supply voltage

#### Features

The connection block features one connector for the incoming supply and one socket for loop-through connection of the supply voltage. The connector and the socket for the supply are linked with one another internally.

Two sockets are available for the incoming PROFINET IO and for loop-through connection. The sockets are not connected to each other in the connection block. The switch in the base unit creates the logical connection.

#### Note

If you disassemble the connection block during operation, only the power supply will be looped through. Data communication to subsequent devices will be interrupted from this module onwards.

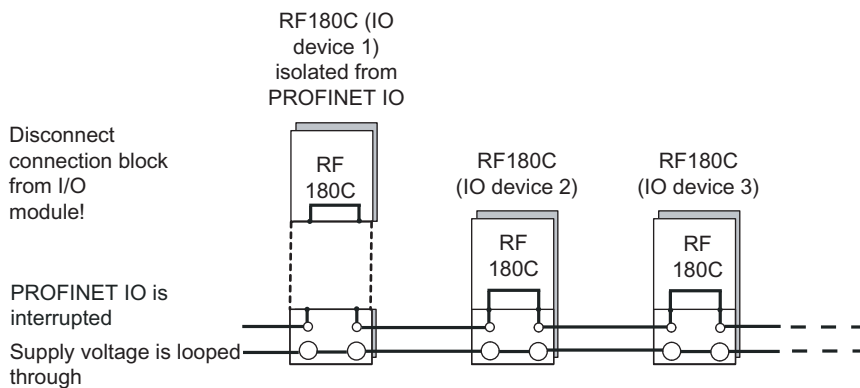

Figure 4-6 Loop-through connection of PROFINET IO and supply voltage

**NOTICE****Ensuring the degree of protection**

The IP65, IP66 or IP67 degree of protection is no longer guaranteed when the connection block is dismantled.

**Notes for wiring**

- If you are wiring your structure, then you must take into account the impact of cable length on supply voltage to the RF180C.

**Example:**

When using a 10 m long cable with a diameter of 1.5 mm<sup>2</sup>, the voltage drop is 2.5 V with a loading of 10 A. This corresponds to 0.25 V at a 1 A load.

- The maximum infeed current for connection block M12, 7/8" is 6 A at 1L+ and 8 A at 2L+. These values must not be exceeded.
- The maximum infeed current of the push-pull connection block is 12 A for 1L+ and 2L+ at up to 40 °C and 8 A for 1L+ and 2L+ at up to 60 °C. These values must not be exceeded.
- Adhere to the current carrying capacity of the connected cables, which depends on the conductor material, the conductor cross-section and the ambient temperature.

**NOTICE****Damage to the device**

If you do not observe the maximum infeed current and the cable cross-section required, this may result in the cable isolation and contacts overheating and to the device being damaged.

**NOTICE****Damage to the device**

A cable cross-section of 2.5 mm<sup>2</sup> is mandatory for an amperage > 8 A!

## 4.4 Wiring an RF180C to a controller with RJ45 connector

A connection can be easily implemented from an RJ-45 connector to an M12 connector.

### Self-assembly of an RJ-45-to-M12 cable

- You will need a preassembled PROFINET cable with M12 connectors at both ends twice the required length. You will also need two RJ-45 connectors for self-assembly. Cut the M12 cable in the center and connect one RJ-45 connector to each free cable end. This will result in two RJ-45-to-M12 cables.
- You will need the following individual parts: RJ-45 and M12 plug-in cables and PROFINET standard cable (unassembled). The parts can be found in the ordering data. You can make up a cable to your own length requirements using these parts.

### Using an RJ-45-to-M12 cabinet feedthrough

This connection variant must always be used when the controller electronics is installed in a cabinet. The following figure shows the connection layout.

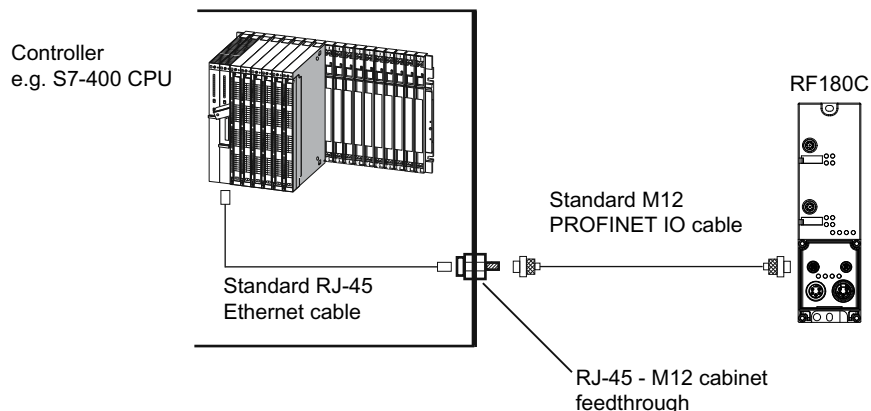

Figure 4-7 Cabinet feedthrough

## 4.5 Connecting the RF180C to functional ground (PE)

### Features

You have to connect the RF180C to the functional ground (PE). For this purpose, a grounding screw for one grounding cable is provided on the communication module.

If a grounded metal mounting surface is used, the bottom mounting screw of the RF180C module already establishes a reliable grounding connection. This eliminates the need for a separate grounding cable.

The connection to functional ground (PE) is also required to deflect the interference currents and for electromagnetic compatibility.

## Requirements

- Always make sure there is a low-resistance connection to the functional ground (PE).
- If you use the fixing screw as grounding connection, the thread of the fixing screw or the contact facing of the fastening nut on the base must be unpainted. This ensures a low-resistance connection.

## Required tools (only if grounding via the grounding cable is required).

- Screwdriver
- Stripping tool
- Crimp tool

## Required accessories (only if grounding via the grounding cable is required).

- M5 x 10 grounding screw and washers
- Grounding cable (copper braided cable) with minimum cross-section of 4 mm<sup>2</sup>
- Cable lug

## Connecting the RF180C to functional ground (PE)

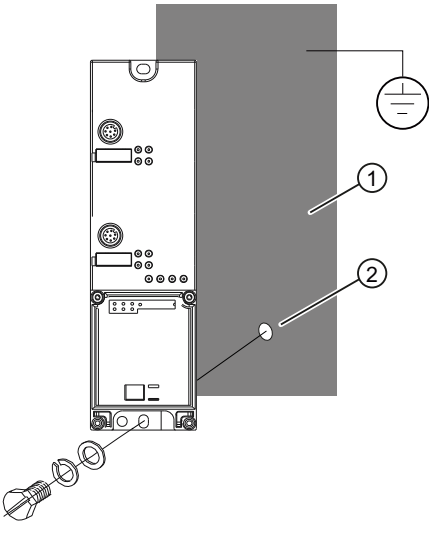
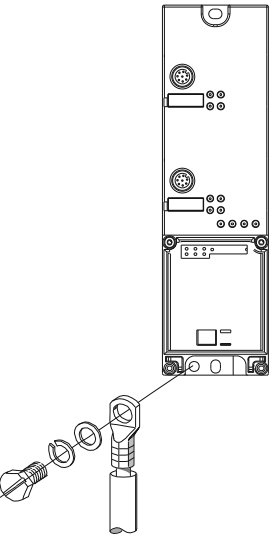
Standard grounding via the securing screw	Optional grounding via a grounding cable
<p>1. Mount the module on the grounded, metallic base as described in section "Mounting the I/O module (Page 12)".</p> <p>① Grounded, metallic base</p> <p>② Unpainted thread or nut base</p>	<p>1. Isolate the grounding cable and secure the cable lug.</p> <p>2. Screw the cable lug on to the communication module (M5 grounding screw). The tightening torque is 3 Nm.</p>
	



# Parameterization

## 5.1 PROFINET IO configuration

### Introduction

The GSDML file allows you to configure RF180C in STEP 7 V5.3 + SP 2 or higher or as of TIA Portal V11. The GSDML file must have been installed beforehand in the configuration software.

### Requirements

- A GSDML file is required to integrate the RF180C into the hardware configuration of the SIMATIC Manager:

GSDML-V2.2-SIEMENS-RF180C-"date in format yyyyymmdd.xml"

You will find the file on the DVD "RFID Systems Software & Documentation (<http://support.automation.siemens.com/WWW/view/en/65102624>) in the directory "Daten\PROFI\_GSD\RF180C".

- The RF180C must have a valid IO device name. The default device name is "RF180C".

### Configuring the RF180C on PROFINET IO

Follow the steps below to configure the RF180C on PROFINET IO with STEP 7:

1. Run HW Config in STEP 7, then select "Options > Install GSD Files".
2. In the dialog that opens, select the GSDML file you want to install and confirm with "OK".  
Result: The RF180C is displayed in the HW catalog under "PROFINET IO > Ident Systems > SIMATIC RFID".
3. Create a new project.
4. Configure the RF180C in HW Config.
5. Set the parameters for the RF180C.
6. Save the configuration, or download it to the PROFINET IO controller.

Follow the steps below to configure the RF180C on PROFINET IO with the TIA Portal:

1. Start the TIA Portal in the project view and call the menu command "Options > Install device description files".
2. In the dialog that opens, select the GSDML file you want to install and confirm with "Install".

Result: The RF180C is displayed in the device configuration under "Other field devices > PROFINET IO > Ident Systems > Siemens AG > SIMATIC RFID".

3. Create a new project.
4. Configure the RF180C in the Network view.
5. Set the parameters for the RF180C.
6. Save the configuration, or download it to the PROFINET IO controller.

You will find further information in the sections "Assigning device names to the I/O device (Page 32)" and "Configuration parameters of the RF180C (Page 36)".

## 5.2 Assigning device names to the I/O device

### Introduction

Each PROFINET IO device is assigned a unique device ID by the manufacturer (MAC address). Each RF180C IO device is addressed by its device name in the configuration and user program.

For detailed information on addressing in PROFINET IO, refer to the "SIMATIC PROFINET system description (<http://support.automation.siemens.com/WW/view/en/19292127/0/en>)".

### Requirements

- RF180C communication module
- To assign the device name to the communications module, one of the following connections is necessary:
  - Online PROFINET connection from the PG to the IO device
  - Ethernet connection from a PC to the IO device (using the "Primary Setup Tool (PST)" software)
- There must be no connection to the CPU.



### Transferring the device name to the communication module

Follow the steps below to transfer the device name using STEP 7:

1. In HW Config, select the menu command "PLC > Ethernet > Edit Ethernet node".
2. Click the "Browse" button for modules that can be accessed online. This will display all accessible PROFINET IO controllers and IO Devices complete with MAC address, IP address (where applicable), device name and device type.
3. Select the required RF180C and click "OK".
4. Assign a device name and click the "Assign name" button.

The device name must be unique within the system and must match the HW Config configuration.

Follow the steps below to transfer the device name with the TIA Portal:

1. In project navigation, select the menu command "Online access > <your online access> > Update accessible devices".  
The available devices are displayed.
2. Select the required RF180C and click the entry "Online & Diagnostics" in the folder of the selected device.

3. Select the option "Functions > Assign name".

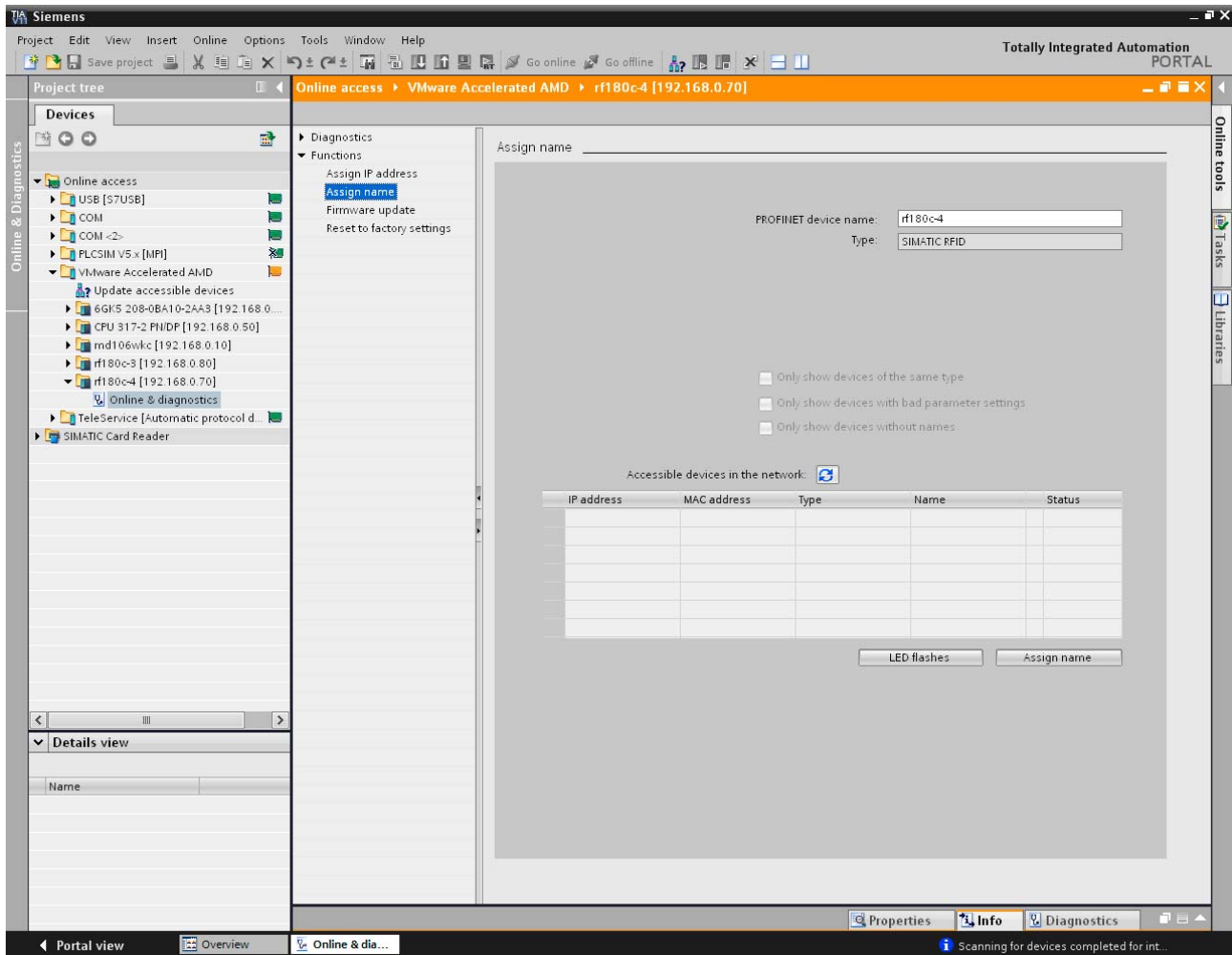

4. Assign a device name and click the "Assign name" button.

The device name must be unique within the system and must match the configuration.

## Result

The device name is saved in connection block and base unit of the RF180C communication module.

## Forwarding the device name when the communication module is replaced

The device name of the IO device is saved in the connection block.

To transfer the device name when the RF180C communication module is replaced, remove the connection block from the "old" RF180C and plug it into the "new" RF180C. The station can be addressed again and will operate as before the replacement.

---

### Note

#### Device replacement without exchangeable medium using LLDP

No device name has to be assigned when replacing a device without removable medium.

Requirement:

- The topology has been configured.
- "Device replacement without removable medium" is activated in the CPU.
- The CM must be in the factory settings status; in other words no device name, IP address = 0. If the CM is not in the factory settings status, the module needs to be reset to the factory settings.

You will find more detailed information on resetting to the factory settings in the section "Reset to factory settings (Page 48)".

---

## Station flash test

If you use more than one IO device, the dialog also displays more than one IO device. In this case, you should compare the MAC address of the device with the indicated MAC address and select the proper IO device.

The identification of IO devices in a system is facilitated by a node flash test.

Follow the steps below to activate the flash test with STEP 7:

1. In the "Edit Ethernet Node" dialog, select one of the indicated IO devices.
2. Click the "Flashing" button.

On the selected IO device both "Link" and "RX/TX" LEDs flash on the connection block.

3. Click the "Flashing Off" button to stop the flashing.

Follow the steps below to activate the flash test with the TIA Portal:

1. In the Project tree, select the menu command "Online access > <your online access> > Update accessible devices".

The available devices are displayed.

2. Select the required RF180C and click the entry "Online & Diagnostics" in the folder of the selected device.
3. Select the option "Functions > Assign name".

5.3 Configuration parameters of the RF180C

4. Click the "LED flashes" button.  
 On the selected IO device both "Link" and "RX/TX" LEDs flash on the connection block.
5. Click the "LED flashes" button to stop the flashing.

### 5.3 Configuration parameters of the RF180C

The GSDML file contains four parameters relevant to RFID that must be set. They are set by selecting the "Object properties" for slot 0 of the RF180C in HW Config.

The parameters are described in the "Function Manual FB 45 (<http://support.automation.siemens.com/WW/view/en/21738808>)". The table below shows the possible settings:

Table 5- 1 Setting of RFID-relevant parameters

Parameter name	Value	Note
USER_Mode	FB 45	Default
	FB 55	-
	RFID standard profile	-
MOBY_Mode	MOBY I / E standard addressing	-
	MOBY I file handler	With later firmware version
	MOBY U / D / RF200 / RF300 / RF600 standard addressing	Default
	MOBY U file handler	With later firmware version
	RF300 Filehandler	-
Baud rate RF200 / RF300 / RF600 / MOBY U/D	19.2 k baud	-
	57.6 k baud	-
	115.2 k baud	Default
Diagnostics with diagnostics messages (see section "Diagnostics (Page 49)")	None	Standard diagnostics only
	Hard errors	Hardware-related messages only
	Hard / soft errors	All messages
Suppression of error LED during startup	None	Default
	Channel 1	-
	Channel 2	-

## 5.4 Input parameters for RF180C

### Input parameters for RF180C with FB 45

Assignment is made in UDT 10.

Table 5- 2 Input parameters for RF180C with FB 45

Address	Name	Permissible values	Comment
+0.0	ASM_address	256, 260, 264, 268, ...	Each RF180C occupies four bytes of I/O in the I/O area of the controller
+2.0	ASM_channel	1, 2	
+8.0	MDS_control	B#16#0, 1	0 = no presence check 1 = presence check
+9.0	ECC_mode	TRUE, FALSE	
+9.1	RESET_long	TRUE, FALSE	TRUE, if MOBY mode = 5 (MOBY U/D; RF200 / RF300)
+10.0	MOBY_mode	B#16#1, 4, 5, 6, 7, 8, 9, A, B	Special features of the MOBY I dialog (8): <ul style="list-style-type: none"> <li>Write/read device must be type SLG4x.</li> <li>The VMDS memory size is 16KB. The INIT command for the VMDS must be specified using 4000 hex.</li> </ul>
+11.0	scanning_time	MOBY I: B#16#00 ... FF MOBY U: B#16#00 ... C8	A value not equal to 00 is only practical if parameters for MOBY_mode have been set accordingly. MOBY D, RF300 reserved (00)
+12.0	option_1	B#16#00, 02, 04	
+13.0	distance_limiting	MOBY U (normal output power): B#16#05, 0A, 0F, 14, 19, 1E, 23 MOBY U (reduced output power): B#16#85, 8A, 8F, 94, 99, 9E, A3 MOBY D: B#16#02 ... 28	MOBY U/D RF200, RF300 reserved (00)
+14.0	multitag	B#16#1	MOBY U/D, RF200, RF300
+15.0	field_ON_control	MOBY U: B#16#0, 1, 2, 3 MOBY D, RF300: B#16#0	MOBY U/D, RF200, RF300
+16.0	field_ON_time	MOBY U: B#16#00 ... FF MOBY D: B#16#00, 01	MOBY U/D RF200, RF300 reserved (00)

Special information on the input parameters for RF180C with FB45 in conjunction with the readers RF620R/RF630R can be found in the "Configuration manual RF620R/RF630R (<http://support.automation.siemens.com/WW/view/en/33287195>)".

**Input parameters for RF180C with FB 55**

Assignment is made in UDT 11.

Table 5- 3 Input parameters for RF180C with FB 55

Address	Name	Type	Initial value	Comment
0.0		STRUCT		
+0.0	ASM_address	INT	256	Input: Base address of the communication module (cyclic word)
+2.0	ASM_channel	INT	1	Input: Number of the channel (1 to 4)
+4.0	command_DB_number	INT	58	Input: Command data block number
+6.0	command_DB_address	INT	0	Input: Start address of data in the BEDE
+8.0	MDS_control	BYTE	B#16#1	Input: Presence check and tag control (0, 1)
+9.0	reserved0	BOOL	FALSE	
+9.1	RESET_long	BOOL	TRUE	Input: true: long RESET telegram, only for MOBY mode 5
+10.0	MOBY_mode	BYTE	B#16#7	Input: MOBY mode (6 and 7 only)
+11.0	scanning time	BYTE	B#16#0	Input: Scanning time for MOBY D/U
+12.0	option 1	BYTE	B#16#0	Input: RESET command option 1
+13.0	distance limiting	BYTE	B#16#F	Input: Range limit
+14.0	multitag	BYTE	B#16#1	Input: max. number of tags in field
+15.0	field ON control	BYTE	B#16#0	Input: BERO mode
+16.0	field ON time	BYTE	B#16#0	Input: BERO time

Special information on the input parameters for RF180C with FB55 in conjunction with the readers RF620R/RF630R can be found in the "Configuration manual RF620R/RF630R (<http://support.automation.siemens.com/WW/view/en/33287195>)".

**Input parameters for RF180C with FB 101/116/132 (RFID standard profile)**

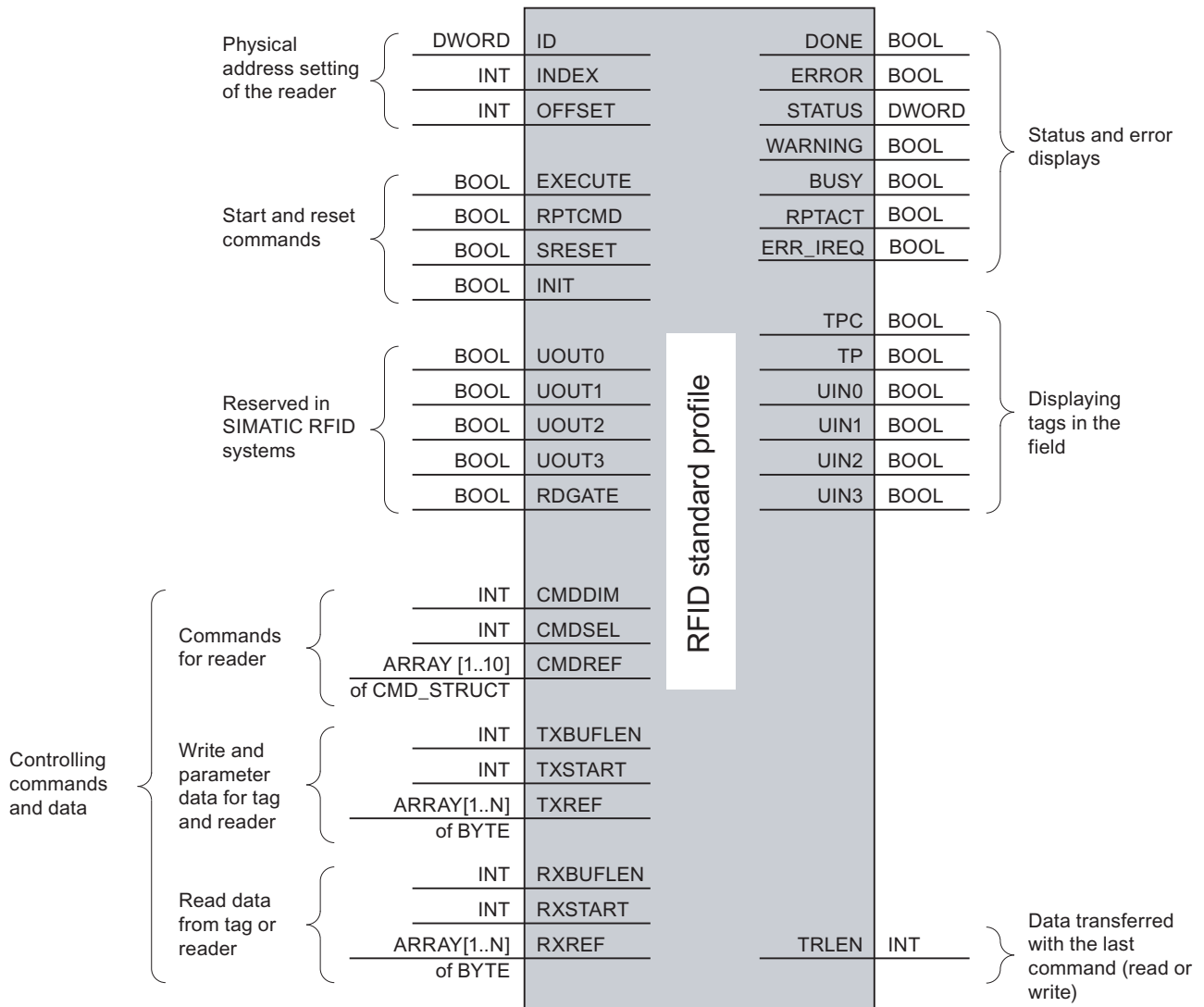

Figure 5-1 Input parameters for RF180C with FB 101/116/132 (RFID standard profile)

## 5.5 Command table of the RF180C

### Table of commands of the RF180C for standard addressing (FB 45)

Assignment is made in the UDT 20 by means of the "command" variable.

Table 5-4 Commands for RF180C with standard addressing

Command code		Description	Available in the RFID system
normal	chained*		
01	41	Write to transponder	all
02	42	Read transponder; read fixed code	all
03	43	Initialize transponder (command is not supported by the RF200)	all
04	44	Reader status	RF200 / RF300 / RF600 / MOBY U / D
08	48	Turn off transponder	MOBY U
0A	4A	Turn antenna on/off	RF200 / RF300 / RF600 / MOBY U / D
0B	4B	Transponder status	RF200 / RF300 / RF600 / MOBY U

\*) Chained commands are not supported by all readers. Please note the relevant information in the RFID system manuals.

### Table of commands of the RF180C for standard addressing (FB 55)

Assignment is made in the UDT 11 by means of the "command" variable.

Table 5-5 Overview of commands

Command [hex]		Commands	Available in the RFID system
normal	chained		
01	41	Write data to transponder	all
02	42	Read data from transponder	all
03	43	Initialize transponder (command is not supported by the RF200)	all
04	44	Reader status	all
07	47	COPY - copy data from transponder1 to transponder2	MOBY U
08	48	END; terminate communication with the transponder	MOBY U
0A	4A	Antenna on/off	all
0B	4B	Transponder status	all
0C	-	GET - scan present transponders (UID with/without data)	all



**RF180C command table with RFID standard profile (FB 101/116/132)**

Assignment is made in the UDT 1 by means of the "command" variable.

Table 5- 6 RF180C commands with RFID standard profile

Commands	Command code		Description
	HEX	ASCII	
CREATE	68	'h'	Creates a new file
DELETE	64	'd'	Deletes a file from the transponder
DEV-STATUS	74	't'	Reads out the status of a communication module
FORMAT	66	'f'	Initializes the transponder
GET-DIRECTORY	6D	'm'	Reads the directory from the transponder
INVENTORY	69	'i'	Requests a list of all currently accessible transponders within the antenna range
MEM-STATUS	73	's'	Reads out the status of a transponder
NEXT	6E	'n'	Does not permit any more operations on a transponder
PHYSICAL-READ	70	'p'	Reads data from a transponder by specifying the physical start address and length
PHYSICAL-WRITE	71	'q'	Writes data to a transponder by specifying the physical start address and length
READ	72	'r'	Reads the data of a file
READ-CONFIG	61	'a'	Reads from the communication module
SET-ATTRIBUTE	6F	'o'	Sets/modifies the attributes belonging to a file
UPDATE	75	'u'	Writes data to a file
WRITE	77	'w'	Writes data to a file
WRITE -CONFIG	78	'x'	Sends new parameters to the communication module



## Maintenance and service

### 6.1 Replacing the RF180C communication module

#### Initial situation

- The RF180C communication module is already mounted. A new RF180C communication module of the same type should be installed.
- The RF180C is wired up and operating.

#### Procedure

1. Remove the 4 fixing screws from the connection block and pull the connection block off the communication module.

---

#### Note

If you disassemble the connection block during operation, only the power supply will be looped through. PROFINET IO communication will be interrupted during module replacement from this node onwards. You will find further information in the Section Loop-through connection of PROFINET IO and supply voltage (Page 26).

---

2. Disconnect the wiring on the communication module.
3. Remove the fixing screws from the communication module and remove it.
4. Locate the new communication module and screw it down firmly.
5. Place the connection block on the new communication module and tighten the 4 fixing screws.

#### Result

The device name for the IO Device remains saved in the connection block, so the new RF180C communication module is included in the data communication by the PROFINET IO controller.

---

#### Note

If the connection block is replaced in addition to the base unit, the RF180C may not start up automatically. In this case, proceed as follows:

---

### What should I do if the RF180C no longer starts up

Under certain conditions, if the connection block is replaced in addition to the base unit, the RF180C may not start up automatically. This is indicated by a permanently lit BF LED.

In this case, check whether the bus configuration in the S7 CPU (created with HW Config) is consistent with the data saved in the RF180C. If necessary, correct the data in the RF180C. You will find further information in the sections "PROFINET IO configuration (Page 31)" and "Assigning device names to the I/O device (Page 32)".

### Overview of naming behavior after replacing a module

The table below shows the naming behavior (assignment of the device name) after replacing a module.

When a device (basic unit or connection block) is replaced, the module that remains in the system automatically assigns a name to the new module.

If both modules fail simultaneously, the user needs to initialize the new modules using the SIMATIC Manager (see section "PROFINET IO configuration (Page 31)" and "Assigning device names to the I/O device (Page 32)").

Table 6- 1 Response to initialization after module replacement

Basic unit	Connection block	Assigning names after replacement
Defective → replaced	-	Automatically with data from the connection block
-	Defective → replaced	Automatically with data from the basic unit
Defective → replaced	Defective → replaced	By the user with the help of the SIMATIC Manager

#### Note

##### Use of devices that already have a name

Even if the device (basic unit or connection block) used for module replacement has already been initialized, it is reinitialized as described in the table.

## 6.2 Firmware update

### Core statement

The firmware of the RF180C communication module can be updated via PROFINET. With firmware version V2.0.0 or higher, an update can be made with the SIMATIC Manager.

---

#### Note

##### Updating the firmware from Version 1 to Version 2

Such an update is generally possible, but it must be implemented by Siemens. Please contact your Siemens representative.

---

### Requirements:

- The ASM is on PROFINET with functional DP communication (basic communication only, no application required).
- The update is possible both with and without a running application.

In the case of a running application, both the update and command processing can be slower.

### Procedure

Follow the steps below to run a firmware update on the RF180C with the SIMATIC Manager:

1. Start the SIMATIC Manager.
2. From the SIMATIC Manager select the menu command "PLC > Display Accessible Nodes".  
The available devices are displayed.
3. Select the desired RF180C node.

4. Select the "PLC > Update Firmware" menu command.

The "Update Firmware" dialog opens.

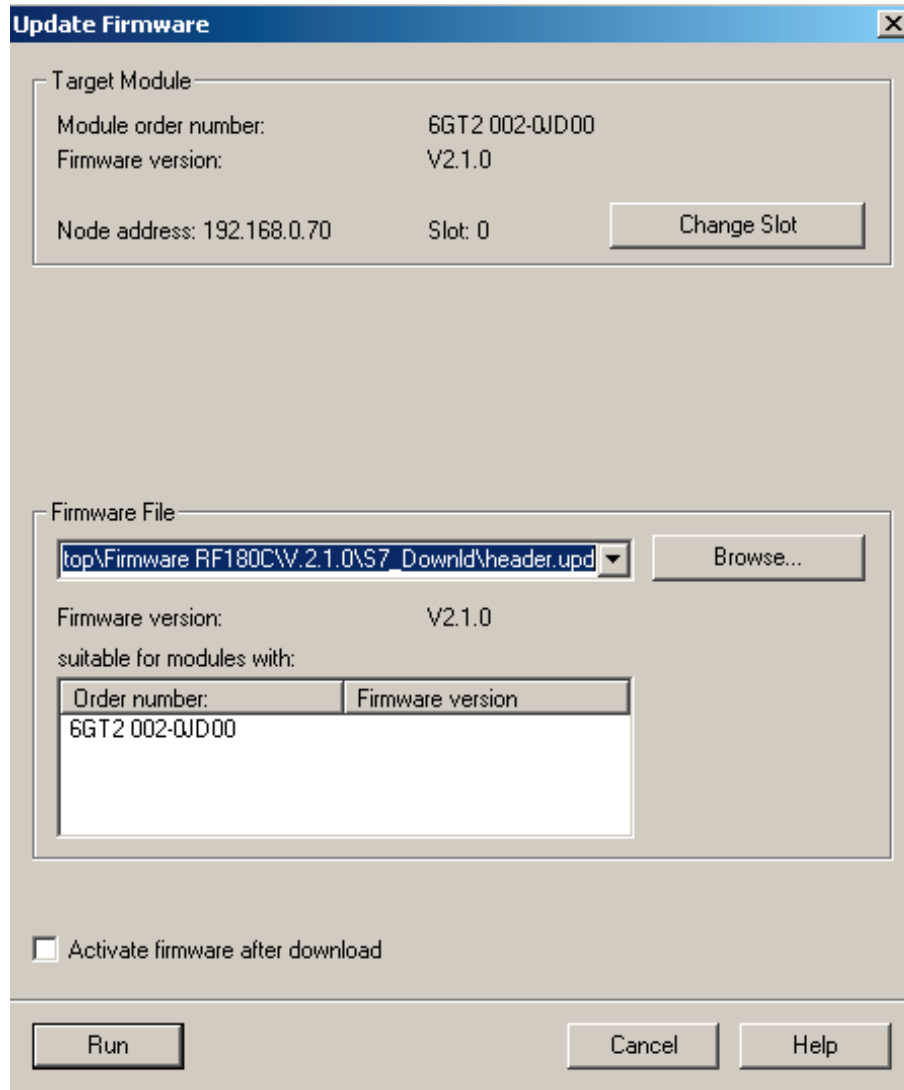

5. In the "Firmware file" drop-down list, select the appropriate directory and select either the file "Cpu\_hd.upd" or "Header.upd".
6. If required, select the "Activate firmware after download" check box.
  - If this option is enabled, a successful update is followed by a new startup of the RF180C during which the new firmware is activated (active commands on the CM/ASM are canceled).
  - Otherwise, the RF180C remains in the previous status following the update. The new firmware is activated the next time the power is cycled.
7. Click the "Run" button to start the update.

While the RF180C is downloading, this is indicated by alternate flashing of "ERR\_1" and "ERR\_2" at approximately 1 Hz. With appropriate parameter settings, an update operation is also reported with diagnostics (see the section "Diagnostics (Page 49)").

Follow the steps below to run a firmware update on the RF180C with the TIA Portal:

1. Start the TIA Portal in the project view.
2. In the Project tree, select the menu command "Online access > <your online access> > Update accessible devices".  
The available devices are displayed.
3. Select the required RF180C and click the entry "Online & Diagnostics" in the folder of the selected device.
4. Select the "Functions > Firmware update" option.

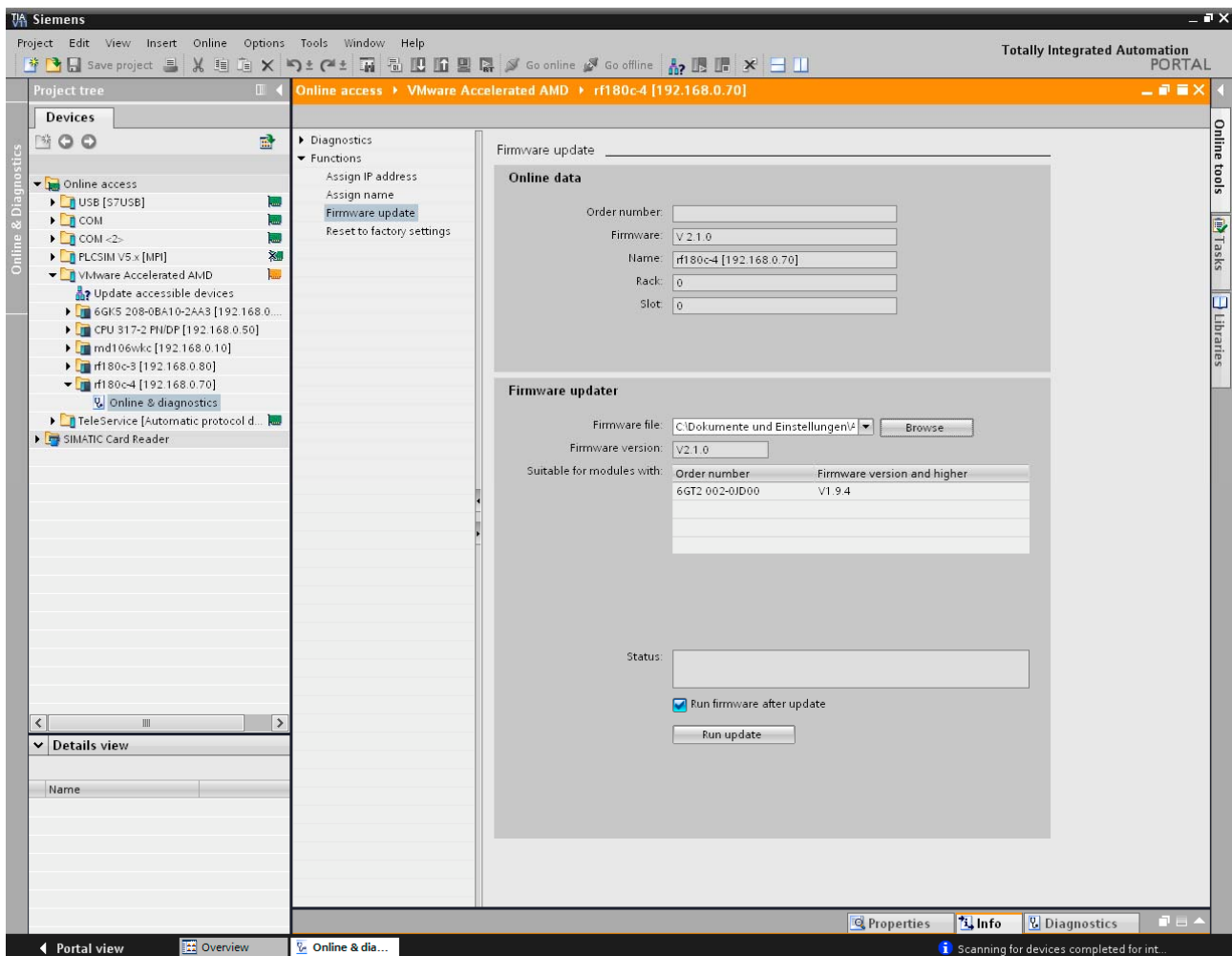

5. In the "Firmware file" drop-down list, select the appropriate directory and select either the file "Cpu\_hd.upd" or "Header.upd".

6. If required, select the "Run firmware after update" check box.
  - If this option is activated, a successful update is followed by a new ramp-up of the RF180C during which the new firmware is activated (active commands on the ASM are canceled).
  - Otherwise, the RF180C remains in the previous status following the update. The new firmware is activated the next time the power is cycled.
7. Click the "Run update" button to start the update.

While the RF180C is downloading, this is indicated by alternate flashing of "ERR\_1" and "ERR\_2" at approximately 1 Hz. With appropriate parameter settings, an update operation is also reported with diagnostics (see the section "Diagnostics (Page 49)").

## 6.3 Reset to factory settings

By resetting to the factory settings, the IP address, subnet mask and router address are set to "0.0.0.0". The device name and the user-specific I&M data (I&M1, I&M2 and I&M3) are deleted. The module must, for example, be reset to the factory settings using LLDP prior to replacing the device without an exchangeable medium.

Follow the steps below to reset the communications module to the factory settings using the SIMATIC Manager:

1. Start the SIMATIC Manager.
2. From the SIMATIC Manager select the menu command "PLC > Display Accessible Nodes".

The available devices are displayed.

3. Select the desired RF180C node.
4. Select the menu command "PLC > Edit Ethernet Node".

The "Edit Ethernet Node" dialog box opens.

5. To reset the communications module to the factory settings, click the "Reset" button in the "Module" area.

Follow the steps below to reset the communications module to the factory settings using the TIA Portal:

1. Start the TIA Portal in the project view.
2. In the Project tree, select the menu command "Online access > <your online access> > Update accessible devices".

The available devices are displayed.

3. Select the required RF180C and click the entry "Online & Diagnostics" in the folder of the selected device.
4. Select the "Functions > Reset to factory settings" option.
5. To reset the communications module to the factory settings, click the "Reset" button.



## Diagnostics

### 7.1 Diagnosis using LEDs

The following figure shows details of the LEDs of the RF180C.

With M12 connection block (7/8")

With push-pull connection block

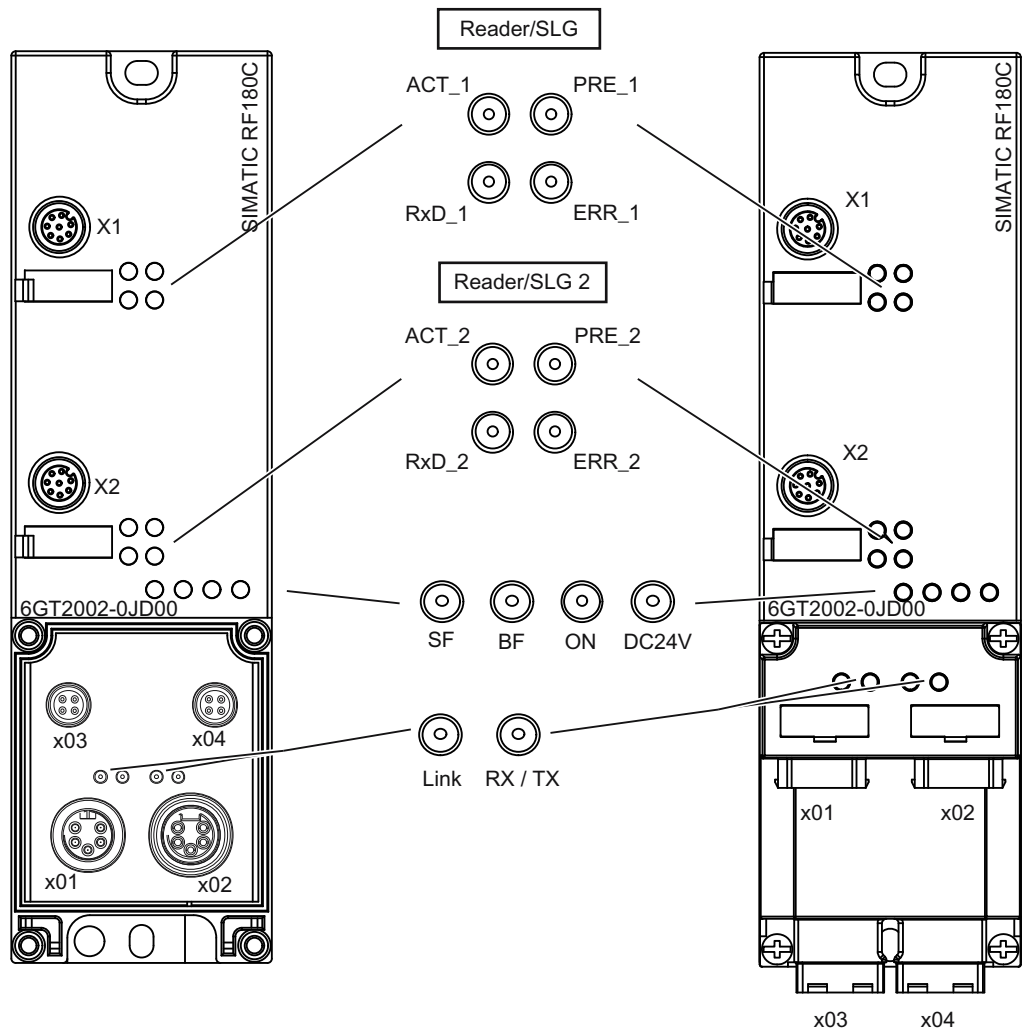

7.1 Diagnosis using LEDs

Table 7- 1 Status LEDs for the RF180C

LEDs	Meaning*
ON	Lights up when the RF180C has completed start-up without errors.
24 VDC	Lights up when the 24 V supply voltage is connected to the RF180C.
ACT_1, ACT_2	The corresponding reader/SLG is active in processing a user command.
ERR_1, ERR_2 *	A flashing pattern indicates the last error to occur.
PRE_1, PRE_2 **	Indicates the presence of a tag/MDS.
RxD_1, RxD_2	Indicates live communication with the reader / SLG. May also indicate malfunctions on the reader / SLG.

\*) The meaning of the individual flash patterns and the associated fault descriptions can be found in the relevant FB documentation.  
 \*\*) In multitag mode, this LED uses a flash interval to indicate the number of data media currently within the range of influence of the reader/SLG.

Table 7- 2 LED display for PROFINET diagnostics

BF	SF	Cause of error	Error handling
On	–	<ul style="list-style-type: none"> <li>Communication module is in start-up mode.</li> <li>No cable inserted</li> </ul>	When the bus is configured correctly, this state ends a few seconds after switching the module on.
Flashes	-	<ul style="list-style-type: none"> <li>There is no connection to the PROFINET IO controller.</li> </ul>	<ul style="list-style-type: none"> <li>Check the PROFINET IO connection.</li> <li>Check your PROFINET IO configuration (device name, GSDML file).</li> <li>Reload the configuration into the RF180C (see the Section "Configuration parameters of the RF180C")</li> </ul>
Off	On	<ul style="list-style-type: none"> <li>A PROFINET diagnostic signal exists.</li> </ul>	<ul style="list-style-type: none"> <li>Analyze the diagnostic data.</li> </ul>
Off	Off	<ul style="list-style-type: none"> <li>Normal mode</li> </ul>	
On	Flashes for 10 seconds after switching on	The firmware has set the MAC addresses 2 and 3 to the default setting. This happens only if the module was updated from Version 1 to Version 2.	

– = Status not relevant

Table 7- 3 LEDs on connection block

Link (green)	Rx / Tx (yellow)	Meaning
Off	Off	No physical connection over PROFINET IO
On	Off	Physical connection over PROFINET IO, no data communication
On	Flashes	Physical connection over PROFINET IO, with data communication
Off	On	Temporary state following switch-on

The table is applicable to both left and right PROFINET IO connection.

Other communication module operating modes are indicated by the PRE, ERR, ACT, SF and ON LEDs:

Table 7- 4 LED display for operating states

ON	BF	SF	PRE_1	ERR_1	ACT_1	PRE_2	ERR_2	ACT_2	Description
Off	Off	Off	Off	Off	Off	Off	Off	Off	Start-up active
On	On	On	On	On	On	On	On	On	LED test on start-up (start PROFINET IO)
Off	Off	On	On	On	Off	On	On	Off	Internal fault
Off	Off	On	On	Off	On	On	Off	On	Checksum error of the firmware
Off	Off	On	Off	Slow flashing	Off	Off	Slow flashing	Off	Firmware update (flashes with every described area)

## 7.2 Parameterization of the diagnostics

Faults are reported by PROFINET IO through the generation of alarms. Alarms are output using OB82. The alarm data can be accessed using SFB 54.

### Parameterizing possibilities

Description of the alarm messages:

- **None**

An alarm will not be issued in the event of an error.

- **Hard errors**

Alarms are generated in the case of the following events:

- Hardware fault (memory test)
- Firmware fault (checksum)
- Break in connection to reader

An alarm is generated and the SF LED on the S7 CPU is activated.

- **Hard / soft errors**

In contrast to hard errors, in this case, errors are also reported that arise during command processing.

An alarm is generated. However the SF LED on the S7 CPU is activated.

An alarm is generated when an event occurs as well as when the event ceases.

#### Incoming alarm

An event occurs and triggers an alarm. The SF LED of the S7 CPU is set as parameterized.

7.3 Structure of the diagnostic data

**Outgoing alarm**

An event no longer exists, an alarm is triggered and the SF LED of the S7 CPU is reset.

For events that only exist momentarily, the reset is delayed by 3 seconds.

You will find more information on parameters in the section "Configuration parameters of the RF180C (Page 36)".

**Further information**

Detailed information about PROFINET IO diagnostics is included in the following documents:

- The manual "SIMATIC PROFINET system description (<http://support.automation.siemens.com/WW/view/en/19292127>)"
- The manual "Migration from PROFIBUS DP to PROFINET IO (<http://support.automation.siemens.com/WW/view/en/19289930>)"

**7.3 Structure of the diagnostic data**

The header of a diagnostic data record comprises 20 bytes of PROFINET IO-specific data. The manufacturer-specific diagnostic data start from Byte 21.

For the RF180C, the diagnostic data are structured in accordance with the PROFIBUS Profile Guideline (PROFIBUS Proxy Guideline, Identification Systems Proxy Ident Function Block) for identification systems with MOBY-specific additional information.

Byte	Name	Contents
<b>PROFIBUS Profile Guideline for Identification Systems</b>		
20	channel_num	Bit 7..0 1d: Relating to Reader 1 2d: Relating to Reader 2
21	function_num	Reserved for a future expansion stage
22	error_decode	Reserved for a future expansion stage
23	error_code_1	Reserved for a future expansion stage
24	error_code_2	Reserved for a future expansion stage
<b>RFID-specific additional information</b>		
25	moby_code_1	Reserved for a future expansion stage
26	moby_code_2	Reserved for a future expansion stage
27	moby_code_3	Reserved for a future expansion stage
28	moby_code_4	Error code To be taken from the corresponding FC/FBs.
29	meldecode	Error code To be taken from the corresponding FC/FBs.
30	counter_high	Continuous event counter high-order byte
31	counter_low	Continuous event counter low-order byte
32	fw_version_high	Firmware version high-order byte
33	fw_version_low	Firmware version low-order byte

## Technical data

<b>Technical specifications - interfaces</b>	
<b>Ethernet interface to the user</b>	
Principle	PROFINET IO
Physical medium	Ethernet over 4-core cable
Duty type	100BaseX full duplex
Transmission rate	100 Mbit/s
Plug-in connection	M12, 4-pin, D coding
Maximum cable length	100 m
Cable type	STP Cat 5
Autonegotiation	Yes
Autocrossing	Yes
Switch function	Yes, internal
IRT	No
RT	Yes
Manufacturer ID (vendor ID)	002AH
Device ID (DeviceID)	0C01H
<b>Serial interface to the reader</b>	
Connector	2 x M12 coupler plugs, 8-pin
Max. cable length	1000 m, dependent on Reader (2 m = standard length; for other standard cables and self-assembled cables, refer to the section Connecting cable to the reader (Page 59))
Readers that can be connected	2 x readers of the RFID families RF200, RF300, RF600, MOBY D/I/E/U
<b>Software functions</b>	
Programming	Depends on the PROFINET IO controller
SIMATIC S7 function blocks	<ul style="list-style-type: none"> <li>• FB 45 (normal addressing without multitag) /</li> <li>• FB 55 (normal addressing single tag and multitag)</li> <li>• RFID standard profile</li> </ul>
Tag addressing	Direct access via addresses
Commands	Initialize tag, read data from tag, write data to tag, etc.

---

**Technical data – electrical details**

---

Supply voltage<sup>1)</sup>

- |                     |                |
|---------------------|----------------|
| • Rated value       | • 24 VDC       |
| • Permissible range | • 20 to 30 VDC |

---

Current consumption without reader / SLG <sup>2)</sup>	max. 500 mA; typ. 100 mA
--	--------------------------

---

Current consumption through reader connection	Each 500 mA
---	-------------

---

Maximum infeed current in the M12 connection block (7/8")	L1 = 6 A
	L2 = 8 A

---

Maximum infeed current in the push-pull connection block	Up to 40 °C:	Up to 60 °C:
	L1 = 12 A <sup>3)</sup>	L1 = 8 A
	L2 = 12 A	L2 = 8 A

---

Galvanic isolation	Yes
--------------------	-----

---

- 1) All supply and signal voltages must be safety extra low voltage (SELV/PELV according to EN 60950) 24 VDC supply: Safe (electrical) isolation of low voltage (SELV / PELV acc. to EN 60950)
- 2) The power supply must provide the current required (max. 500 mA) during brief power failures of ≤ 20 ms.
- 3) **A cable cross-section of 2.5 mm<sup>2</sup> is mandatory for a current > 8 A.**

---

**Technical data – mechanical details**

---

Dimensions (W x H x D)

- |  |                    |
|--|--------------------|
| • Base unit only                             | • 60 x 210 x 30 mm |
| • Base unit with M12, 7/8" connection block  | • 60 x 210 x 54 mm |
| • Basic unit with push-pull connection block | • 60 x 216 x 10 mm |

---

Mounting position	All mounting positions are possible
-------------------	-------------------------------------

Weight

- |                              |                 |
|------------------------------|-----------------|
| • Basic device               | • Approx. 210 g |
| • M12, 7/8" connection block | • Approx. 230 g |
| • Push-pull connection block | • Approx. 120 g |

---

Degree of protection	IP67
----------------------	------

---

---

**Technical specifications - environmental conditions**

---

Temperature range during operation	0 ... +60 °C
Temperature range during transportation and storage	-40 to +70 °C
Degree of protection	IP67
Vibration during operation	According to IEC 61131-2: 0.75 mm (10 Hz to 58 Hz) 10 g (58 Hz to 150 Hz)
Shock resistance, shock during operation	Acc. to IEC 61131-2: 30 g
MTBF (Mean Time Between Failures) in years	
<ul style="list-style-type: none"> <li>• Basic device</li> <li>• Connection block</li> </ul>	<ul style="list-style-type: none"> <li>• 121 years</li> <li>• 1100 years</li> </ul>
Approvals	<ul style="list-style-type: none"> <li>• cULus (file E116536)</li> <li>• FCC Code of Federal Regulations, CFR 47, Part 15, Sections 15.107 and 15.109 (Class A)</li> <li>• PI-certified according to Conformance Class B</li> </ul>

---





## Dimension drawings

### 9.1 Dimension drawing for RF180C with fixing holes

Dimension drawing of an RF180C with M12 bus connection block (7/8" PN)

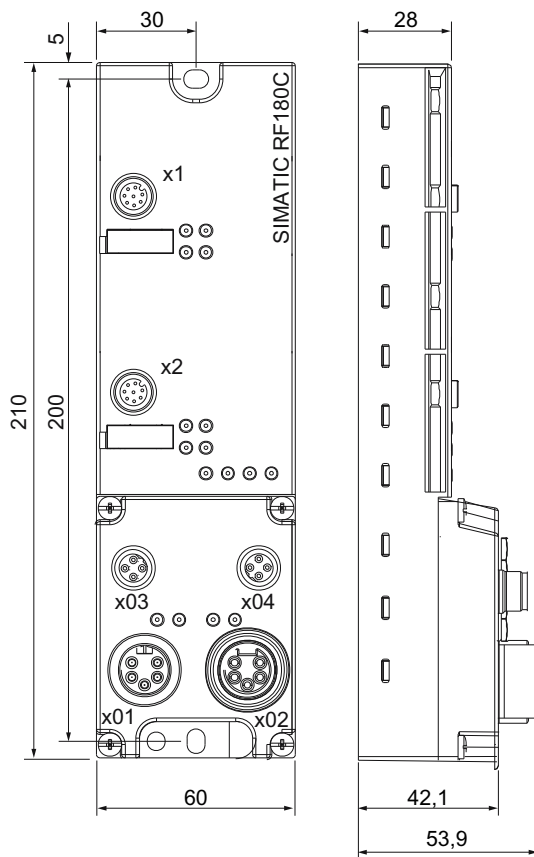

Figure 9-1 Dimension drawing of an RF180C with M12 bus connection block (7/8" PN)

Dimension drawing of an RF180C with push-pull bus connection block

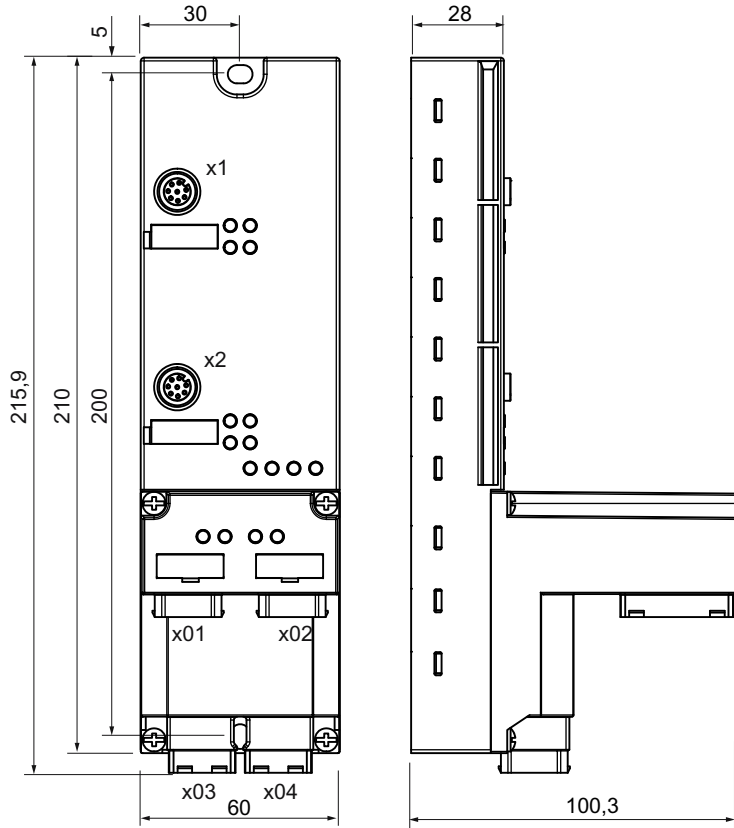

Figure 9-2 Dimension drawing of an RF180C with push-pull bus connection block

## Connecting cable to the reader

### 10.1 Routing of standard cables

#### Available cables

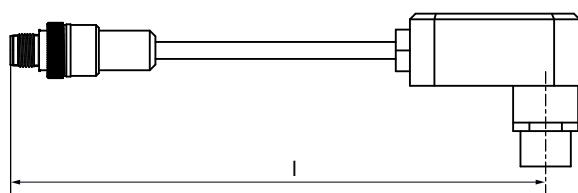

Figure 10-1 M12 connecting cable ↔ reader

- Connecting cable MOBY E / I / U
- Length: 2 m, 5 m

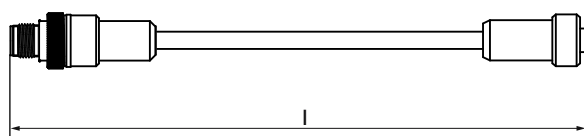

Figure 10-2 Connecting cable/extension cable M12 ↔ M12

- RF300, RF600 connecting cable
- Extension cable for all RFID systems
- Length: 2 m, 5 m, 10 m, 20 m, 50 m

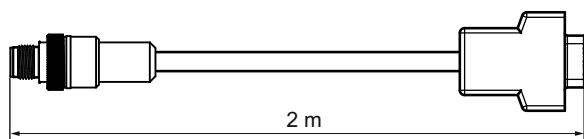

Figure 10-3 Connecting cable M12 ↔ sub-D (MOBY D)

- Connecting cable MOBY D
- Length: 2 m

**Maximum cable length**

The RF180C can be operated with every reader configuration with the maximum cable length of 50 m. In some situations, longer connecting cables up to 1000 m are possible. The current consumption of the connected reader must however be taken into account. You will find further information in the relevant system manuals.

Joining more than two cables to form a long cable should be avoided due to the additional contact resistances.

**Pin assignment**

Table 10- 1 M12 connecting cable ↔ reader

M12 connector (male)		Reader connector (female)	
	1	2	
	2	5	
	3	3	
	4	4	
	5	6	
	6	1	
	7	–	
	8	7	

Table 10- 2 Connecting cable/extension cable M12 ↔ M12

	1	1	
	2	2	
	3	3	
	4	4	
	5	5	
	6	6	
	7	7	
	8	8	

Table 10- 3 Connecting cable M12 ↔ sub-D 9-pin

M12 connector (male)	Sub-D connector (female)		
	1	–	
	2	5	
	3	7	
	4	3	
	5	2	
	6	6	
	7	–	
	8	1, 8	
<p>Note:          Readers with D-sub connectors must be supplied with 24 VDC via an additional connector.</p>			

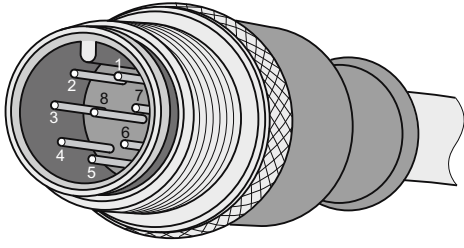
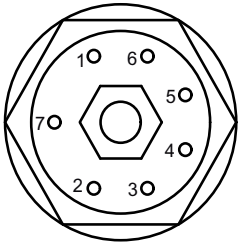
## 10.2 Self-assembled cable

A reader/SLG connector plug with screw terminals is available for users who want to individually assemble their own cables (refer to the relevant system manual). Cables and reader/SLG connector plugs can be ordered from the catalog "ID 10 Industrial Identification Systems".

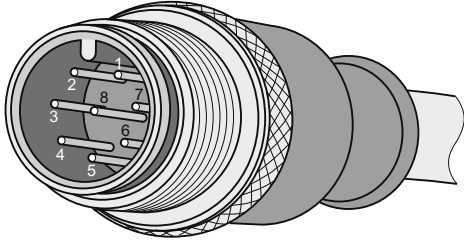
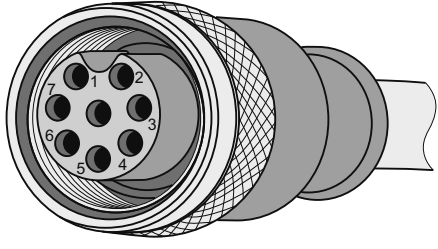
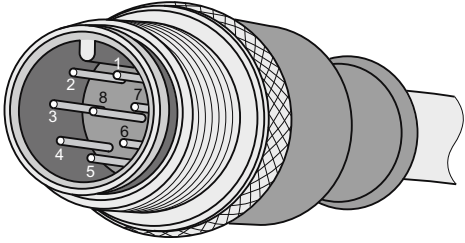
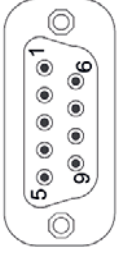
### Cable structure

You will need cables of the following specifications for self-assembled cables:

- 7 x 0.25 mm<sup>2</sup>
- LIYC11Y 7 x 0.25

### Connectors

M12 connectors can be obtained from the relevant specialist dealers (e.g. Binder).

### Pin assignment

The pin assignment is listed in the following table.

Table 10-4 Pin assignment

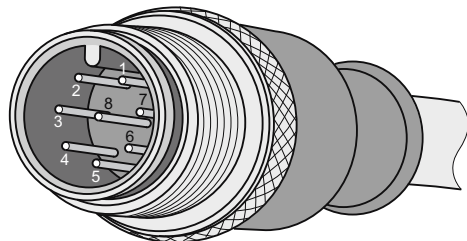
M12 connector (male)	Pin	Signal	Core color
	1	1L+ (+ 24 V)	Note data sheet provided by cable manufacturer
	2	-RxD	
	3	0 V	
	4	RxD	
	5	TxD	
	6	-TxD	
	7	Free	
	8	Functional ground (PE)/shield	

## Ordering data

Table 11- 1 Ordering data - RF180C

Ordering data	Order number
RF180C communications module max. 2 readers can be connected	6GT2002-0JD00
Connection block M12, 7/8" PN	6GT2002-1JD00
Push-pull connection block, RJ-45	6GT2002-2JD00
Labels 20 x 7 mm (1 x pack of 340)	3RT1900-1SB20

Table 11- 2 Ordering data - accessories for connection block M12 7/8" PN

Ordering data	Order number
IE plug-in cable for PROFINET (pre-assembled trailing cable with two M12 connectors, 4-pin, code D)	6XV1870-8Axxx *
7/8"-plug-in cable for supply voltage (5 x 1.5 mm <sup>2</sup> ) (pre-assembled trailing power cable with two 5-pin 7/8" connectors)	6XV1822-5Bxxx *
Trailing power cable (5 x 1.5 mm <sup>2</sup> ) (not preassembled; min. length 20 m, max. length 1000 m)	6XV1830-8AH10
Connector plug 7/8" for supply voltage; (1 x pack of 5) <ul style="list-style-type: none"> <li>• with pin insert</li> <li>• with socket insert</li> </ul>	6GK1905-0FA00 6GK1905-0FB00
RJ-45 plug-in cable with metal casing and FC connection system, 180 ° cable outlet;(1 x pack of 1)	6GK1901-1BB10-2AA0
Cabinet feedthrough for conversion from M12 connector system (D coded, IP65) to RJ-45 connector system (IP20) ;(1 x pack of 5)	6GK1901-0DM20-2AA5
M12 plug-in cable with metal casing and fast connection system, 180° cable outlet (D coded) ; (1 x pack of 1)	6GK1901-0DB10-6AA0
M12 covering caps	3RX9802-0AA00
Covering caps 7/8" (1 x pack of 10)	6ES7194-3JA00-0AA0
PROFINET standard cable 2x2, Type A, unassembled; minimum order quantity 20 m	6XV1840-2AH10

\*) These cables are available in different lengths. See Catalog IK PI for more details

Table 11- 3 Ordering data - accessories for push-pull connection block

Ordering data	Order number
Trailing power cable (5 x 1.5 mm <sup>2</sup> ) (not preassembled; min. length 20 m, max. length 1000 m)	6XV1830-8AH10
Push-pull cable connector for 1L+/2L+, not preassembled	6GK1907-0AB10-6AA0
Push-pull cable connector for RJ-45, not preassembled	6GK1901-1BB10-6AA0
Caps for push-pull sockets (1L+/2L+), 5 items per package, 1 item	6ES7194-4JA50-0AA0
Caps for push-pull sockets RJ-45, 5 items per package, 1 item	6ES7194-4JD50-0AA0
PROFINET standard cable 2x2, Type A, unassembled; minimum order quantity 20 m	6XV1840-2AH10

Table 11- 4 Ordering data - RFID accessories

Ordering data	Order number
SLG cable MOBY I / E / U; 2 m	6GT2091-0FH20
SLG cable MOBY I / E / U; 5 m	6GT2091-0FH50
SLG cable MOBY D; 2 m	6GT2691-0FH20
Reader cable RF200 / RF300, RF600 extension cable RF200 / RF300 / RF600 / MOBY I / E / U / D; 2 m	6GT2891-0FH20
Reader cable RF200 / RF300, RF600 extension cable RF200 / RF300 / RF600 / MOBY I / E / U / D; 5 m	6GT2891-0FH50
Reader cable RF200 / RF300, RF600 extension cable RF200 / RF300 / RF600 / MOBY I / E / U / D; 10 m	6GT2891-0FN10
Reader cable RF200 / RF300, RF600 extension cable RF200 / RF300 / RF600 / MOBY I / E / U / D; 20 m	6GT2891-0FN20
Reader cable RF200 / RF300, RF600 extension cable RF200 / RF300 / RF600 / MOBY I / E / U / D; 50 m	6GT2891-0FN50
Reader cable for RF300; connector on the reader is angled; 2 m	6GT2891-0JH20
DVD "RFID Systems Software & Documentation" with FB 45 / FB 55, GSDML files, drivers, tools and RFID documentation	6GT2080-2AA20



## Service & Support

### Technical Support

You can access technical support for all IA/DT projects via the following:

- Phone: + 49 (0) 911 895 7222
- Fax: + 49 (0) 911 895 7223
- E-mail (<mailto:support.automation@siemens.com>)
- Internet: Online support request form: (<http://www.siemens.com/automation/support-request>)

### Contacts

If you have any further questions on the use of our products, please contact one of our representatives at your local Siemens office.

The addresses are found on the following pages:

- On the Internet (<http://www.siemens.com/automation/partner>)
- In Catalog CA 01
- In Catalog ID 10 specifically for industrial communication / industrial identification systems

### Service & support for industrial automation and drive technologies

You can find various services on the Support homepage ([www.siemens.com/automation/service&support](http://www.siemens.com/automation/service&support)) of IA/DT on the Internet.

There you will find the following information, for example:

- Our newsletter containing up-to-date information on your products.
- Relevant documentation for your application, which you can access via the search function in "Product Support".
- A forum for global information exchange by users and specialists.
- Your local contact for IA/DT on site.
- Information about on-site service, repairs, and spare parts. Much more can be found under "Our service offer".

### RFID homepage

For general information about our identification systems, visit RFID homepage (<http://www.siemens.com/ident/rfid>).

### Technical documentation on the Internet

A guide to the technical documentation for the various products and systems is available on the Internet:

SIMATIC Guide manuals ([www.siemens.com/simatic-tech-doku-portal](http://www.siemens.com/simatic-tech-doku-portal))

### Online catalog and ordering system

The online catalog and the online ordering system can also be found on the Industry Mall Homepage (<http://www.siemens.com/industrymall>).

### Training center

We offer appropriate courses to get you started. Please contact your local training center or the central training center in

D-90327 Nuremberg.

Phone: +49 (0) 180 523 56 11

(€ 0.14 /min. from the German landline network, deviating mobile communications prices are possible)

For information about courses, see the SITRAIN homepage ([www.sitrain.com](http://www.sitrain.com)).