

# BMXART0814

analog isolated low level input module,  
Modicon X80, 8 inputs, 40mV positive or  
negative



## Main

Range of Product	Modicon X80
Product or Component Type	Analog input module
Electrical connection	40 ways 2 connectors
Isolation between channels	Isolated
Input level	Low level
Analogue input number	8
Analogue input type	Voltage +/- 1.28 V Voltage +/- 160 mV Voltage +/- 320 mV Voltage +/- 40 mV Voltage +/- 640 mV Voltage +/- 80 mV Resistor 400 Ohm 2 wires Resistor 400 Ohm 3 wires Resistor 400 Ohm 4 wires Resistor 4000 Ohm 2 wires Resistor 4000 Ohm 3 wires Resistor 4000 Ohm 4 wires Temperature probe -100...+260 °C Cu 10 Temperature probe -100...+450 °C Pt 100 UL/JIS Temperature probe -100...+450 °C Pt 1000 UL/JIS Temperature probe -200...+850 °C Pt 100 IEC Temperature probe -200...+850 °C Pt 1000 IEC Temperature probe -60...+180 °C Ni 100 Temperature probe -60...+180 °C Ni 1000 Thermocouple +130...+1820 °C thermocouple B Thermocouple +270...+1300 °C thermocouple N Thermocouple -200...+600 °C thermocouple U Thermocouple -200...+760 °C thermocouple J Thermocouple -200...+900 °C thermocouple L Thermocouple -270...+1000 °C thermocouple E Thermocouple -270...+1370 °C thermocouple K Thermocouple -270...+400 °C thermocouple T Thermocouple -50...+1769 °C thermocouple R Thermocouple -50...+1769 °C thermocouple S

## Complementary

Analog/digital conversion	Sigma delta 16 bits
Analogue input resolution	15 bits + sign
Permitted overload on inputs	+/- 7.5 V +/- 1.28 V +/- 7.5 V +/- 160 mV +/- 7.5 V +/- 320 mV +/- 7.5 V +/- 40 mV +/- 7.5 V +/- 640 mV +/- 7.5 V +/- 80 mV
Common mode rejection	120 dB 50/60 Hz
Differential mode rejection	60 dB 50/60 Hz
Cold junction compensation	External by Pt100 probe
Type of filter	First order digital filtering
Nominal read cycle time	400 ms with temperature probe 200 ms with thermocouple

The information provided in this documentation contains general descriptions and/or technical characteristics of the products contained herein. This documentation is not intended as a substitute for and is not to be used for determining suitability or reliability of these products for specific user applications. It is the duty of any such user or integrator to perform the appropriate and complete risk analysis, evaluation and testing of the products with respect to the relevant specific application or use thereof. Neither Schneider Electric Industries SAS nor any of its affiliates or subsidiaries shall be responsible or liable for misuse of the information contained herein.

Measurement error	+/- 0.7 °C Ni 1000 25 °C +/- 2 °C Pt 100 0...60 °C +/- 2 °C Pt 1000 0...60 °C +/- 2.1 °C Ni 100 25 °C +/- 2.1 °C Pt 100 25 °C +/- 2.1 °C Pt 1000 25 °C +/- 2.7 °C thermocouple U 25 °C +/- 2.8 °C thermocouple J 25 °C +/- 3 °C Ni 100 0...60 °C +/- 3 °C thermocouple L 25 °C +/- 3.2 °C thermocouple R 25 °C +/- 3.2 °C thermocouple S 25 °C +/- 3.5 °C thermocouple B 25 °C +/- 3.7 °C thermocouple E 25 °C +/- 3.7 °C thermocouple K 25 °C +/- 3.7 °C thermocouple N 25 °C +/- 3.7 °C thermocouple T 25 °C +/- 4 °C Cu 10 0...60 °C +/- 4 °C Cu 10 25 °C +/- 4.5 °C thermocouple J 0...60 °C +/- 4.5 °C thermocouple L 0...60 °C +/- 4.5 °C thermocouple R 0...60 °C +/- 4.5 °C thermocouple S 0...60 °C +/- 4.5 °C thermocouple U 0...60 °C +/- 5 °C thermocouple B 0...60 °C +/- 5 °C thermocouple E 0...60 °C +/- 5 °C thermocouple K 0...60 °C +/- 5 °C thermocouple N 0...60 °C +/- 5 °C thermocouple T 0...60 °C <= 0.15 % of full scale +/- 1.28 V 0...60 °C <= 0.15 % of full scale +/- 160 mV 0...60 °C <= 0.15 % of full scale +/- 320 mV 0...60 °C <= 0.15 % of full scale +/- 640 mV 0...60 °C <= 0.15 % of full scale +/- 80 mV 0...60 °C <= 0.2 % of full scale 4000 Ohm 0...60 °C 0.05 % of full scale +/- 1.28 V 25 °C 0.05 % of full scale +/- 160 mV 25 °C 0.05 % of full scale +/- 320 mV 25 °C 0.05 % of full scale +/- 40 mV 25 °C 0.05 % of full scale +/- 640 mV 25 °C 0.05 % of full scale +/- 80 mV 25 °C 0.12 % of full scale 400 Ohm 25 °C 0.12 % of full scale 4000 Ohm 25 °C <= 0.2 % of full scale +/- 40 mV 0...60 °C <= 0.3 % of full scale 400 Ohm 0...60 °C 1.3 °C Ni 1000 0...60 °C
Temperature drift	25 ppm/°C 400 Ohm 25 ppm/°C 4000 Ohm 25 ppm/°C Ni 1000 25 ppm/°C thermocouple B 25 ppm/°C thermocouple E 25 ppm/°C thermocouple J 25 ppm/°C thermocouple K 25 ppm/°C thermocouple L 25 ppm/°C thermocouple N 25 ppm/°C thermocouple R 25 ppm/°C thermocouple S 25 ppm/°C thermocouple T 25 ppm/°C thermocouple U 30 ppm/°C +/- 1.28 V 30 ppm/°C +/- 160 mV 30 ppm/°C +/- 320 mV 30 ppm/°C +/- 40 mV 30 ppm/°C +/- 640 mV 30 ppm/°C +/- 80 mV 30 ppm/°C Cu 10 30 ppm/°C Ni 100 30 ppm/°C Pt 100 30 ppm/°C Pt 1000
Recalibration	Internal

Detection type	Open circuit Cu 10 Open circuit Ni 100 Open circuit Ni 1000 Open circuit Pt 100 Open circuit Pt 1000 Open circuit thermocouple B Open circuit thermocouple E Open circuit thermocouple J Open circuit thermocouple K Open circuit thermocouple L Open circuit thermocouple N Open circuit thermocouple R Open circuit thermocouple S Open circuit thermocouple T Open circuit thermocouple U
Maximum wiring resistance	20 Ohm 2 wires Cu 10 20 Ohm 2 wires Ni 100 20 Ohm 2 wires Pt 100 20 Ohm 3 wires Cu 10 20 Ohm 3 wires Ni 100 20 Ohm 3 wires Pt 100 200 Ohm 2 wires Ni 1000 200 Ohm 2 wires Pt 1000 200 Ohm 3 wires Ni 1000 200 Ohm 3 wires Pt 1000 50 Ohm 4 wires Cu 10 50 Ohm 4 wires Ni 100 50 Ohm 4 wires Pt 100 500 Ohm 4 wires Ni 1000 500 Ohm 4 wires Pt 1000
Measurement resolution	0.1 °C Cu 10 0.1 °C Ni 100 0.1 °C Ni 1000 0.1 °C Pt 100 0.1 °C Pt 1000 0.1 °C thermocouple B 0.1 °C thermocouple E 0.1 °C thermocouple J 0.1 °C thermocouple K 0.1 °C thermocouple L 0.1 °C thermocouple N 0.1 °C thermocouple R 0.1 °C thermocouple S 0.1 °C thermocouple T 0.1 °C thermocouple U 1280/2exp14 mV +/- 1.28 V 160/2exp14 mV +/- 160 mV 320/2exp14 mV +/- 320 mV 40/2exp14 mV +/- 40 mV 12.5 mOhm 400 Ohm 125 mOhm 4000 Ohm 640/2exp14 mV +/- 640 mV 80/2exp14 mV +/- 80 mV
Maximum conversion value	+/- 100 % 400 Ohm +/- 100 % 4000 Ohm +/- 102.5 % +/- 1.28 V +/- 102.5 % +/- 160 mV +/- 102.5 % +/- 320 mV +/- 102.5 % +/- 40 mV +/- 102.5 % +/- 640 mV +/- 102.5 % +/- 80 mV
MTBF reliability	900000 H
Operating altitude	0...6561.68 ft (0...2000 m) 2000...5000 m with derating factor
Status LED	1 LED (Green) RUN 1 LED per channel (Green) channel diagnostic 1 LED (Red) ERR 1 LED (Red) I/O
Net Weight	0.36 lb(US) (0.165 kg)
Current consumption	150 mA 3.3 V DC 50 mA 24 V DC

## Environment

Vibration resistance	3 gn
Shock resistance	30 gn
Ambient Air Temperature for Storage	-40...185 °F (-40...85 °C)
Ambient Air Temperature for Operation	32...140 °F (0...60 °C)
Relative humidity	5...95 % 131 °F (55 °C) without condensation
IP Degree of Protection	IP20
Directives	2014/35/EU - low voltage directive 2014/30/EU - electromagnetic compatibility
Product Certifications	CE[RETURN]EAC[RETURN]UL[RETURN]CSA[RETURN]Merchant Navy[RETURN]RCM
Standards	IEC 61131-2 IEC 61000-6-4 IEC 61000-6-2 EN 61010-2-201
Environmental characteristic	3C3 IEC 60721-3-3 3C4 IEC 60721-3-3

## Ordering and shipping details

Category	18160-MODICON M340
Discount Schedule	PC34
GTIN	3595863966794
Returnability	Yes
Country of origin	FR

## Packing Units

Unit Type of Package 1	PCE
Number of Units in Package 1	1
Package 1 Height	2.20 in (5.600 cm)
Package 1 Width	4.45 in (11.300 cm)
Package 1 Length	4.72 in (12.000 cm)
Package 1 Weight	7.37 oz (209.000 g)
Unit Type of Package 2	S02
Number of Units in Package 2	15
Package 2 Height	5.91 in (15.000 cm)
Package 2 Width	11.81 in (30.000 cm)
Package 2 Length	15.75 in (40.000 cm)
Package 2 Weight	7.60 lb(US) (3.449 kg)

## Offer Sustainability

California proposition 65	WARNING: This product can expose you to chemicals including: Lead and lead compounds, which is known to the State of California to cause cancer and birth defects or other reproductive harm. For more information go to <a href="http://www.P65Warnings.ca.gov">www.P65Warnings.ca.gov</a>
REACH Regulation	 <a href="#">REACH Declaration</a>
EU RoHS Directive	Pro-active compliance (Product out of EU RoHS legal scope)
Mercury free	Yes
China RoHS Regulation	 <a href="#">China RoHS Declaration</a>
RoHS exemption information	 Yes
WEEE	The product must be disposed on European Union markets following specific waste collection and never end up in rubbish bins.

## Contractual warranty

Warranty	18 months
----------	-----------

Modules Mounted on Racks

Dimensions

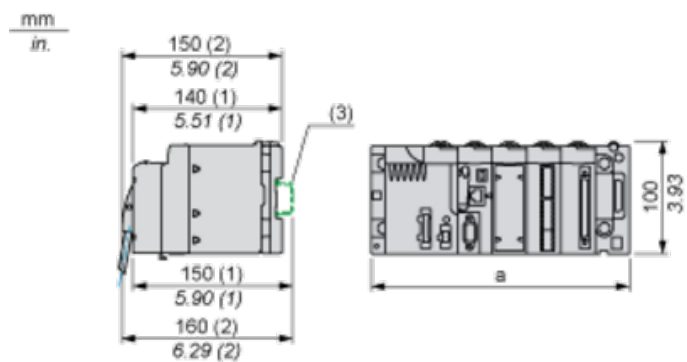

(1) With removable terminal block (cage, screw or spring).

(2) With FCN connector.

(3) On AM1 ED rail: 35 mm wide, 15 mm deep. Only possible with BMXXBP0400/0400H/0600/0600H/0800/0800H rack.

Rack references	a in mm	a in in.
BMXXBP0400 and BMXXBP0400H	242.4	09.54
BMXXBP0600 and BMXXBP0600H	307.6	12.11
BMXXBP0800 and BMXXBP0800H	372.8	14.68
BMXXBP1200 and BMXXBP1200H	503.2	19.81

Connections and Schema

Below example shows a probe configuration with:

- Channel 0/4: Thermocouple
- Channel 1/5: 2-wires RTD
- Channel 2/6: 3-wires RTD
- Channel 3/7: 4-wires RTD

Module Front View - cabling view

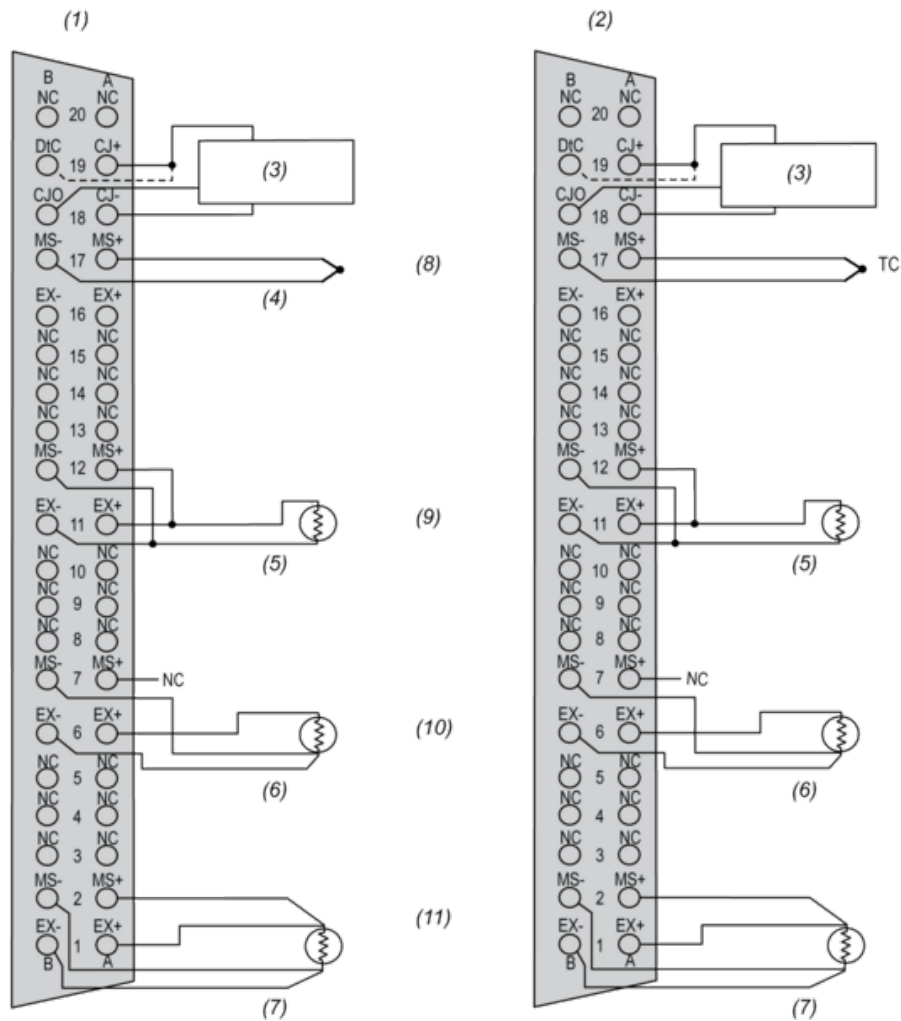

- (1) Left connector  
 (2) Right connector (BMX ART 414 only)  
 (3) Cold Junction temperature sensor  
 (4) Thermocouple  
 (5) 2-wire RTD probe  
 (6) 3-wire RTD probe  
 (7) 4-wire RTD probe  
 (8) Channel 4/0  
 (9) Channel 5/1  
 (10) Channel 6/2  
 (11) Channel 7/3

MS+ RTD Measure + input / Thermocouple + input  
 MS- RTD Measure - input / Thermocouple - input  
 EX+ RTD probe current generator + output

EX- RTD probe current generator - output

NC Not connected

DtC The CJC sensor detection input is connected to CJ+ if the sensor type is DS600. It is not connected (NC) if the sensor type is LM31.

NOTE: The CJC sensor is needed for TC only.