



## PAKK KIT FOR USE WITH PA CIRCUIT BREAKER KIRK KEY INTERLOCK

### KIT INSTALLATION

**⚠ DANGER**

**HAZARD OF ELECTRICAL SHOCK, BURN OR EXPLOSION.**

**Turn OFF all power supplying the equipment before installing or removing circuit breaker.**

Failure to observe these precautions will cause death, personal injury, or electrical shock.

- 1** Remove handle from circuit breaker and retain cap and nylon screw.

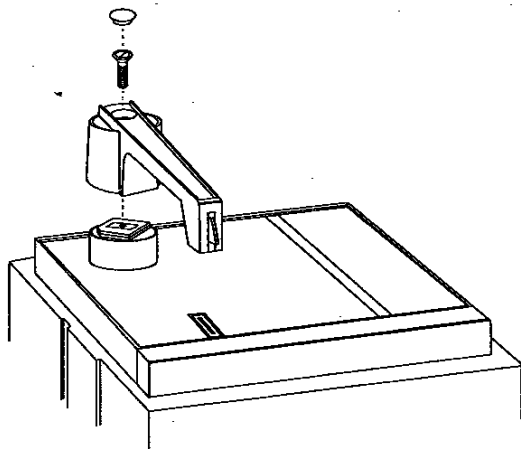

PA1000A.0

- 2** Slip interlock bracket onto handle as shown.

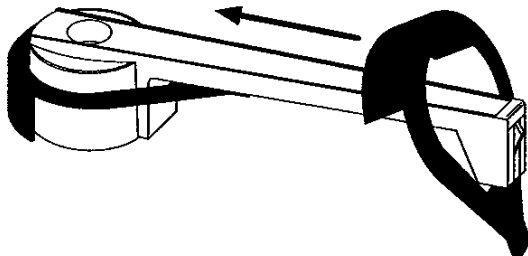

PA1001A.0

- 3** Secure bracket to circuit breaker handle with two drive screws included in kit.

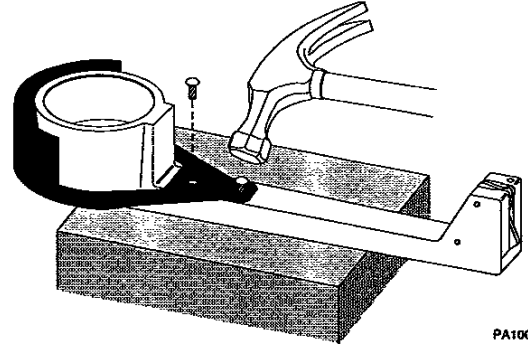

PA1002A.0

- 4** Replace handle-interlock assembly using original nylon screw and cap.

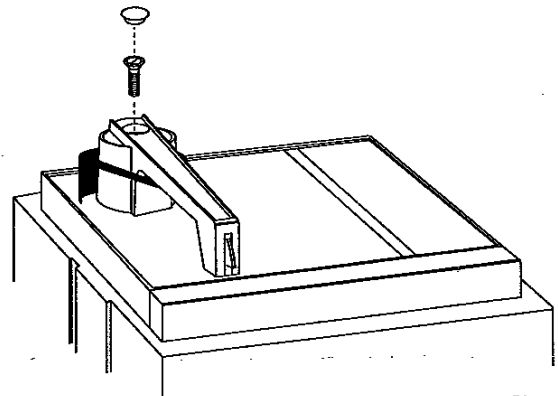

PA1003A.0

Square D Company  
PO Box 3069, 3700 Sixth St SW  
Cedar Rapids IA 52406-3069 USA  
Technical Services: 1-800-634-2003

Square D, and  are Registered Trademarks of Square D Company.

Electrical equipment should be serviced only by qualified electrical maintenance personnel. No responsibility is assumed by Square D for any consequences arising out of the use of this material.