

HORIZONTAL CROSS BUS RATED 800A CONTINUOUS. (UNIT SUPPLIED WITH ALL ALUMINUM BUSSING).

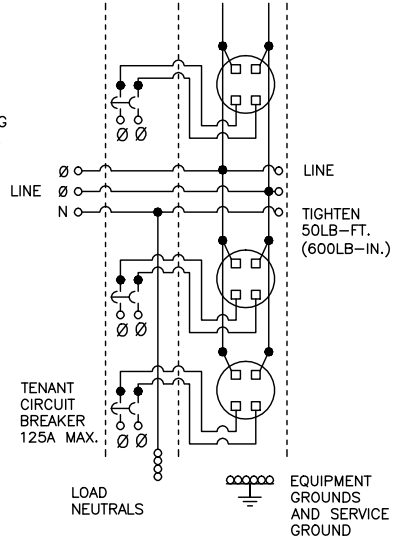

5TH JAW OMITTED ON RING STYLE TYPE EZM UNITS IF REQUIRED ORDER ONE 5TH JAW KIT PER METER SOCKET POSITION (CATALOG NUMBER: 5J)

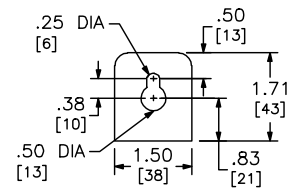

TOP MOUNTING BRACKET

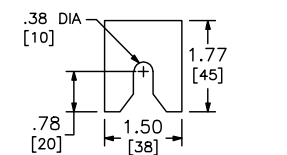

BOTTOM MOUNTING BRACKET

KNOCKOUTS		
SYMBOL	CONDUIT SIZE	
	IN	MM
A	.50	13
B	.75	19
C	1.00	25
D	1.25	32
E	1.50	38

DUAL DIMENSIONS: INCHES MILLIMETERS

NOTES:  
 FINISH - GRAY BAKED ENAMEL POWDER COAT PAINT OVER CLEANED GALVANNEALED STEEL.  
 UL LISTED AS A MODULAR-PANELBOARD - FILE E131840, VOL. M SUITABLE FOR USE AS SERVICE EQUIPMENT.  
 WHEN SERVICE GROUND IS TERMINATED IN THIS DEVICE A BONDING JUMPER (2/0 AWG MAX) IS REQUIRED TO CONNECT EQUIPMENT GROUND TO LOAD NEUTRAL AND IS LIMITED FOR USE WITH 800A MAX MAIN LUGS TAP BOX. UNMETERED COMPARTMENTS ARE SEALABLE BY UTILITY.  
 SEE MARKINGS ON TENANT CIRCUIT BREAKER FOR WIRE RANGES. GANGABLE MULTI-METERING EQUIPMENT IS DESIGNED FOR WALL MOUNTING ONLY (NOT SUITABLE FOR USE AS FLOOR STANDING EQUIPMENT).

SYSTEM TYPE (IN)	SERVICE PROVIDED (OUT)	CATALOG NUMBER	METER SOCKET TYPE	NUMBER OF POSITIONS	TENANT CIRCUIT BREAKER (ORDER SEPARATELY)	LOAD NEUTRAL WIRE RANGE	EQUIPMENT GROUND AND SERVICE GROUND WIRE RANGE
1Ø 3W 120/240VAC	1Ø 3W 120/240VAC	EZM113125	4-JAW RING TYPE WITHOUT BYPASS	3	QO,QO-VH,OR QOH 125A MAX 2-POLE	(4) #14-2/0 AWG CU (4) #12-2/0 AWG AL	(6) #14-2/0 AWG CU (6) #12-2/0 AWG AL

EZ METER-PAK GANGABLE MULTI-METERING EQUIPMENT  
 125A MAX 1PH 3W METER SOCKET/CIRCUIT BREAKER  
 3-GANG BRANCH UNITS  
 RAINPROOF NEMA TYPE 3R ENCLOSURES

**SCHNEIDER ELECTRIC**  
 by Schneider Electric  
 DWG# 3121  
 NO.