



Main

Range of Product	Modicon STB distributed I/O solution
Product or Component Type	HART interface kit
Kit composition	STBXTS215018 terminal spring clamp connector STBAHI8321 module STBXBA3000 base

Complementary

Number of Channels	4
Function Available	Hot swap Virtual placeholder I/O mapping
Program characteristics	Floating points
[Us] rated supply voltage	24 V
Voltage range	19.2...30 V
Network type	DC
Protection Type	Reverse polarity protection
Current consumption	400 mA 5.25 V DC logic bus
Insulation between channels	> 30 Vdc
Type of filter	Passive 3 dB 25 Hz
Status LED	1 LED (Green) module status (RDY) 1 LED (Red) module error (ERR) 4 LEDs (green/red) channel status (CH1 to CH4)
Height	1.09 in (27.8 mm)
Depth	2.97 in (75.5 mm)
Width	5.05 in (128.3 mm)
Net Weight	0.24 lb(US) (0.11 kg)

Environment

Product Certifications	UL FM Class 1 Division 2 CSA
Marking	CE
Ambient Air Temperature for Operation	32...140 °F (0...60 °C)
Ambient Air Temperature for Storage	-40...185 °F (-40...85 °C)
Relative Humidity	95 % without condensation

Ordering and shipping details

Category	18215-ADVANTYS STB I/O
Discount Schedule	PC32
GTIN	3595864155210
Nbr. of units in pkg.	1
Package weight(Lbs)	4.76 oz (135.0 g)

Returnability	No
Country of origin	FR

Packing Units

Unit Type of Package 1	PCE
Package 1 Height	0.98 in (2.5 cm)
Package 1 width	3.15 in (8 cm)
Package 1 Length	5.12 in (13 cm)
Unit Type of Package 2	S02
Number of Units in Package 2	5
Package 2 Weight	23.81 oz (675.0 g)
Package 2 Height	5.91 in (15 cm)
Package 2 width	11.81 in (30 cm)
Package 2 Length	15.75 in (40 cm)

Offer Sustainability

Sustainable offer status	Green Premium product
California proposition 65	WARNING: This product can expose you to chemicals including: Lead and lead compounds, which is known to the State of California to cause cancer and birth defects or other reproductive harm. For more information go to www.P65Warnings.ca.gov
REACH Regulation	REACH Declaration
EU RoHS Directive	Pro-active compliance (Product out of EU RoHS legal scope) EU RoHS Declaration
Mercury free	Yes
RoHS exemption information	Yes
China RoHS Regulation	China RoHS Declaration
Environmental Disclosure	Product Environmental Profile
Circularity Profile	End Of Life Information
WEEE	The product must be disposed on European Union markets following specific waste collection and never end up in rubbish bins.

Contractual warranty

Warranty	18 months
----------	-----------

Dimensions

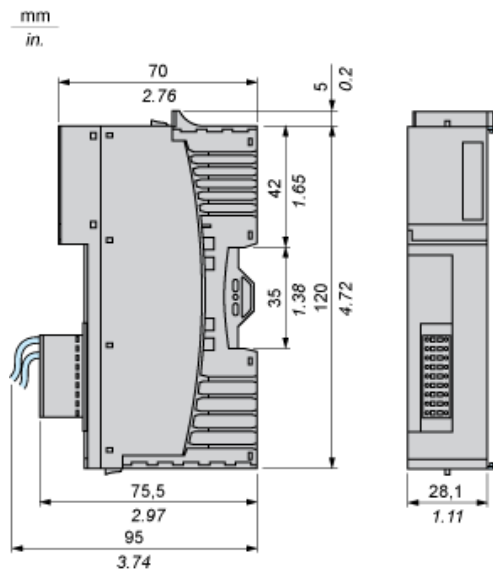

Wiring Diagram

Connection to the Removable Spring Type Terminals

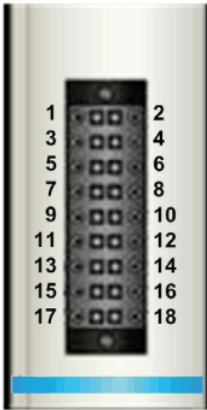
to Analog I/O	Pin		Pin	to HART instrument
FILTER_1 (+)	1	2	HART_1 (+)	
RETURN_1 (-)	3	4	RETURN_1 (-)	
FILTER_2 (+)	5	6	HART_2 (+)	
RETURN_2 (-)	7	8	RETURN_2 (-)	
FILTER_3 (+)	9	10	HART_3 (+)	
RETURN_3 (-)	11	12	RETURN_3 (-)	
FILTER_4 (+)	13	14	HART_4 (+)	
RETURN_4 (-)	15	16	RETURN_4 (-)	
Not Connected	17	18	Not Connected	

Connection Using the HART Interface Module with I/O

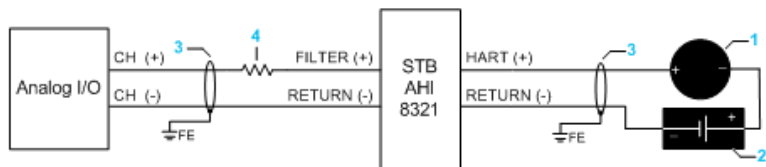

- (1) HART field instrument
- (2) 24 Vdc external power supply.
- (3) FE ground connection
- (4) External resistor

Connection Using the HART Interface Module without I/O

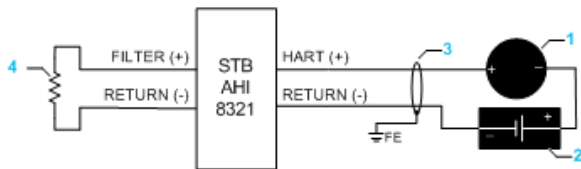

- (1) HART field instrument
- (2) 24 Vdc external power supply.
- (3) FE ground connection
- (4) External resistor