

# BRS3

3-phase stepper motor

Motor manual

V2.02, 03.2011



## **Important information**

This manual is part of the product.

Carefully read this manual and observe all instructions.

Keep this manual for future reference.

Hand this manual and all other pertinent product documentation over to all users of the product.

Carefully read and observe all safety instructions and the chapter "Before you begin - safety information".

Some products are not available in all countries.

For information on the availability of products, please consult the catalog.

Subject to technical modifications without notice.

All details provided are technical data which do not constitute warranted qualities.

Most of the product designations are registered trademarks of their respective owners, even if this is not explicitly indicated.

## Table of contents



<b>Important information</b> . . . . .	<b>2</b>
<b>Table of contents</b> . . . . .	<b>3</b>
<b>About this manual</b> . . . . .	<b>7</b>
<b>1 Introduction</b> . . . . .	<b>9</b>
1.1 Motor family . . . . .	9
1.2 Options, accessories and cables . . . . .	10
1.3 Nameplate . . . . .	11
1.4 Type code BRS36 . . . . .	12
1.5 Type code BRS39 . . . . .	13
1.6 Type code BRS3A . . . . .	14
<b>2 Before you begin - safety information</b> . . . . .	<b>15</b>
2.1 Qualification of personnel . . . . .	15
2.2 Intended use . . . . .	15
2.3 Hazard categories . . . . .	16
2.4 Basic information . . . . .	17
2.5 Standards and terminology . . . . .	19
<b>3 Technical Data</b> . . . . .	<b>21</b>
3.1 General features . . . . .	21
3.2 Ambient conditions . . . . .	22
3.3 Service life . . . . .	23
3.4 IP degree of protection . . . . .	24
3.5 Motor-specific data . . . . .	25
3.5.1 Motor-specific data BRS36 . . . . .	25
3.5.2 Motor-specific data BRS39 . . . . .	26
3.5.3 Motor-specific data BRS3A . . . . .	26
3.6 Characteristic curves . . . . .	28
3.6.1 Characteristic curves BRS36 . . . . .	28
3.6.2 Characteristic curves BRS39 . . . . .	31
3.6.3 Characteristic curves BRS3A . . . . .	34

3.7	Dimensions . . . . .	36
3.7.1	Dimensional drawing BRS36 . . . . .	36
3.7.2	Dimensional drawing BRS39 . . . . .	38
3.7.3	Dimensional drawing BRS3A . . . . .	40
3.8	Shaft-specific data . . . . .	42
3.8.1	Force for pressing on . . . . .	42
3.8.2	Shaft load . . . . .	43
3.9	Motor versions . . . . .	45
3.10	Options . . . . .	46
3.10.1	Holding brake . . . . .	46
3.10.2	Encoder . . . . .	48
3.11	Conditions for UL 1004 . . . . .	49
3.12	Certifications . . . . .	49
3.13	Declaration of conformity . . . . .	50
<b>4</b>	<b>Installation . . . . .</b>	<b>51</b>
4.1	Before mounting . . . . .	53
4.1.1	Calculation of installation space . . . . .	54
4.2	Electromagnetic compatibility, EMC . . . . .	55
4.3	Mechanical installation . . . . .	56
4.4	Electrical installation . . . . .	58
4.4.1	Motor connection . . . . .	60
4.4.2	Encoder connection . . . . .	62
4.4.3	Holding brake connection . . . . .	63
<b>5</b>	<b>Commissioning . . . . .</b>	<b>65</b>
5.1	Preparing for commissioning . . . . .	66
<b>6</b>	<b>Diagnostics and troubleshooting . . . . .</b>	<b>67</b>
6.1	Mechanical problems . . . . .	67
6.2	Electrical problems . . . . .	67
<b>7</b>	<b>Accessories and spare parts . . . . .</b>	<b>69</b>
7.1	Accessories . . . . .	69
7.2	Motor cables . . . . .	69
7.3	Encoder cables . . . . .	69
<b>8</b>	<b>Service, maintenance and disposal . . . . .</b>	<b>71</b>
8.1	Service address . . . . .	71
8.2	Maintenance . . . . .	71
8.3	Changing the motor . . . . .	73
8.4	Shipping, storage, disposal . . . . .	73

**9 Glossary**..... **75**

- 9.1 Units and conversion tables ..... 75
  - 9.1.1 Length..... 75
  - 9.1.2 Mass..... 75
  - 9.1.3 Force..... 75
  - 9.1.4 Power ..... 75
  - 9.1.5 Rotation ..... 76
  - 9.1.6 Torque..... 76
  - 9.1.7 Moment of inertia ..... 76
  - 9.1.8 Temperature ..... 76
  - 9.1.9 Conductor cross section..... 76
- 9.2 Terms and Abbreviations..... 77

**10 Index**..... **79**



## About this manual

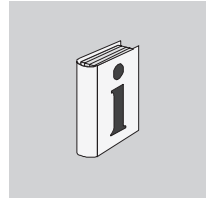

	<p>This manual is valid for BRS standard products. Chapter 1 "Introduction" lists the type code for this product. The type code allows you to identify whether your product is a standard product or a customized version.</p>
<i>Source manuals</i>	<p>The latest versions of the manuals can be downloaded from the Internet at:</p> <p><a href="http://www.schneider-electric.com">http://www.schneider-electric.com</a></p>
<i>Corrections and suggestions</i>	<p>We always try to further optimize our manuals. We welcome your suggestions and corrections.</p> <p>Please get in touch with us by e-mail: <a href="mailto:techcomm@schneider-electric.com">techcomm@schneider-electric.com</a>.</p>
<i>Work steps</i>	<p>If work steps must be performed consecutively, this sequence of steps is represented as follows:</p> <ul style="list-style-type: none"> <li>■ Special prerequisites for the following work steps</li> <li>▶ Step 1</li> <li>◁ Specific response to this work step</li> <li>▶ Step 2</li> </ul> <p>If a response to a work step is indicated, this allows you to verify that the work step has been performed correctly.</p> <p>Unless otherwise stated, the individual steps must be performed in the specified sequence.</p>
<i>Making work easier</i>	<p>Information on making work easier is highlighted by this symbol:</p> <div style="display: flex; align-items: center; margin-bottom: 10px;">  <p><i>Sections highlighted this way provide supplementary information on making work easier.</i></p> </div>
<i>SI units</i>	<p>SI units are the original values. Converted units are shown in brackets behind the original value; they may be rounded.</p> <p>Example: Minimum conductor cross section: 1.5 mm<sup>2</sup> (AWG 14)</p>
<i>Glossary</i>	<p>Explanations of special technical terms and abbreviations.</p>
<i>Index</i>	<p>List of keywords with references to the corresponding page numbers.</p>





# 1 Introduction

# 1

## 1.1 Motor family

The motors are 3-phase stepper motors with a very high power density. They carry out precise step-by-step movements that are controlled by a drive.

The 3-phase stepper motors are accurate, powerful and sturdy and excel with a high power density. Due to the high holding torque, a gearbox is not required in most cases. Sine commutation allows for almost fully resonance-free operation of the motor.

A drive system consists of the 3-phase stepper motor and the appropriate drive. Maximum performance requires the motor and drive to be adapted to each other.

*Features* The motors excel with the following features:

- Positioning accuracy and speed accuracy
- Very quiet and almost resonance-free
- Dynamics and high peak torque
- High power density
- Excellent dynamics
- Broad torque range
- Special winding for low phase currents
- Motor connections via flying leads, terminal box or connector
- Easy commissioning
- Low maintenance
- High overload capability

## 1.2 Options, accessories and cables

The motors are optionally available with:

- Encoder
- Holding brake
- Connector
- Various degrees of protection

For the options, see the technical data in the various motor descriptions.

The following accessories are available:

- Holding brake controller HBC
- Cables
- Gearbox

See chapter 7 "Accessories and spare parts" for pre-assembled motor cables and encoder cables for the drive systems.

### 1.3 Nameplate

The nameplate contains the following data:

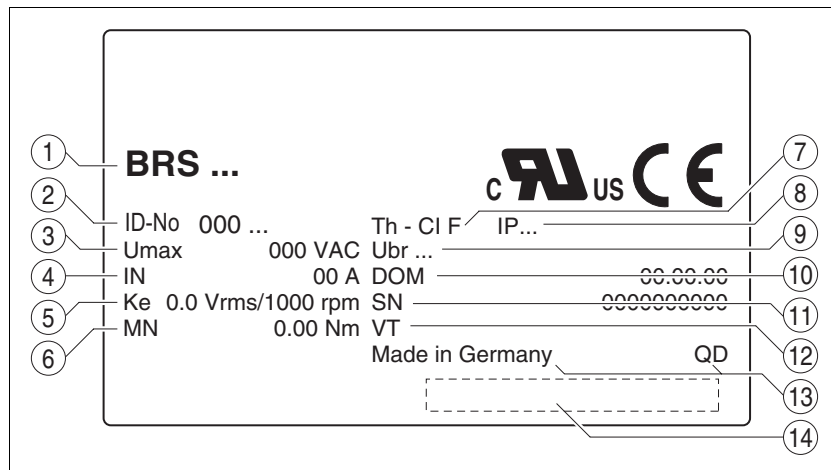

Figure 1.1 Nameplate

- (1) Motor type, see type code
- (2) Order no.
- (3) Maximum supply voltage
- (4) Nominal current
- (5) Voltage constant
- (6) Nominal torque
- (7) Temperature class
- (8) Degree of protection
- (9) Nominal voltage of the holding brake
- (10) Date of manufacture
- (11) Serial number
- (12) Variable torque
- (13) Country of manufacture, site
- (14) Barcode

1.4 Type code BRS36

	BRS3	6	8	W	1	3	0	A	B	A
<b>Product family</b> 3-phase stepper motors										
<b>Motor size</b> 6 = 57.2 mm flange										
<b>Length</b> 4 = 42 mm <sup>1)</sup> 6 = 55 mm <sup>1)</sup> 8 = 79 mm										
<b>Winding</b> F = 48 V <sub>dc</sub> H = 48 V <sub>dc</sub> N = 130 V <sub>dc</sub> W = 325 V <sub>dc</sub>										
<b>Mechanical interface - shaft and degree of protection</b> 0 = Smooth shaft 6.35 mm; degree of protection: shaft bushing IP 41, housing IP 56 1 = Smooth shaft 8 mm; degree of protection: shaft bushing IP 41, housing IP 56 S = Customized version										
<b>Mechanical interface - centering collar</b> 3 = 38 mm										
<b>Encoder</b> 0 = Without encoder 1 = Incremental encoder (1000 pulses/revolution)										
<b>Holding brake</b> A = Without holding brake F = With holding brake										
<b>Connection version</b> A = Flying leads version <sup>1)</sup> B = Terminal box C = Connector										
<b>Second shaft end</b> A = Without second shaft end B = With second shaft end <sup>2)</sup>										

1) Not for W windings

2) Only available for motors without a holding brake.

## 1.5 Type code BRS39

	BRS3	9	7	W	2	6	0	A	B	A
<b>Product family</b> 3-phase stepper motors										
<b>Motor size</b> 9 = 85 mm flange										
<b>Length</b> 7 = 68 mm A = 98 mm B = 128 mm										
<b>Winding</b> F = 48 V <sub>dc</sub> H = 48 V <sub>dc</sub> N = 130 V <sub>dc</sub> W = 325 V <sub>dc</sub>										
<b>Mechanical interface - shaft and degree of protection</b> 2 = Smooth shaft 9.5 mm; degree of protection: shaft bushing IP 41, housing IP 56 <sup>1)</sup> 3 = Smooth shaft 12 mm; degree of protection: shaft bushing IP 41, housing IP 56 <sup>1)</sup> 4 = Smooth shaft 14 mm; degree of protection: shaft bushing IP 41, housing IP 56 <sup>2)</sup> 5 = Woodruff key 9.5 mm; degree of protection: shaft bushing IP 41, housing IP 56 <sup>1)</sup> 6 = Woodruff key 12 mm; degree of protection: shaft bushing IP 41, housing IP 56 <sup>1)</sup> 7 = Woodruff key 14 mm; degree of protection: shaft bushing IP 41, housing IP 56 <sup>2)</sup> A = Smooth shaft 9.5 mm; degree of protection: shaft bushing IP 56 <sup>3)</sup> , housing IP 56 <sup>1)</sup> B = Smooth shaft 12 mm; degree of protection: shaft bushing IP 56 <sup>3)</sup> , housing IP 56 <sup>1)</sup> C = Smooth shaft 14 mm; degree of protection: shaft bushing IP 56 <sup>3)</sup> , housing IP 56 <sup>2)</sup> K = Woodruff key 9.5 mm; degree of protection: shaft bushing IP 56 <sup>3)</sup> , housing IP 56 <sup>1)</sup> L = Woodruff key 12 mm; degree of protection: shaft bushing IP 56 <sup>3)</sup> , housing IP 56 <sup>1)</sup> M = Woodruff key 14 mm; degree of protection: shaft bushing IP 56 <sup>3)</sup> , housing IP 56 <sup>2)</sup> S = Customized version										
<b>Mechanical interface - centering collar</b> 6 = 60 mm 7 = 73 mm										
<b>Encoder</b> 0 = Without encoder 1 = Incremental encoder (1000 pulses/revolution)										
<b>Holding brake</b> A = Without holding brake F = With holding brake										
<b>Connection version</b> A = Flying leads version <sup>4)</sup> B = Terminal box C = Connector										
<b>Second shaft end</b> A = Without second shaft end B = With second shaft end <sup>5)</sup>										

1) Only available for lengths 7 and A.

2) Only available for length B.

3) Degree of protection IP56 is reached with a shaft sealing ring. If a shaft sealing ring is used, the maximum speed of rotation must be limited to 3000 min<sup>-1</sup>.

4) Not available for W windings

5) Only available for motors without a holding brake.

1.6 Type code BRS3A

	BRS3	A	C	W	8	5	0	A	B	A
<b>Product family</b> 3-phase stepper motors										
<b>Motor size</b> A = 110 mm flange										
<b>Length</b> C = 180 mm D = 230 mm										
<b>Winding</b> W = 325 V <sub>dc</sub>										
<b>Mechanical interface - shaft and degree of protection</b> 8 = Parallel key 19 mm; degree of protection: shaft bushing IP 41, housing IP 56 S = Customized version										
<b>Mechanical interface - centering collar</b> 5 = 56 mm										
<b>Encoder</b> 0 = Without encoder 1 = Incremental encoder (1000 pulses/revolution)										
<b>Holding brake</b> A = Without holding brake F = With holding brake										
<b>Connection version</b> B = Terminal box C = Connector										
<b>Second shaft end</b> A = Without second shaft end B = With second shaft end <sup>1)</sup>										

1) Only available for motors without a holding brake.

## 2 Before you begin - safety information

# 2

### 2.1 Qualification of personnel

Only appropriately trained persons who are familiar with and understand the contents of this manual and all other pertinent product documentation are authorized to work on and with this product. In addition, these persons must have received safety training to recognize and avoid hazards involved. These persons must have sufficient technical training, knowledge and experience and be able to foresee and detect potential hazards that may be caused by using the product, by changing the settings and by the mechanical, electrical and electronic equipment of the entire system in which the product is used.

All persons working on and with the product must be fully familiar with all applicable standards, directives, and accident prevention regulations when performing such work.

### 2.2 Intended use

This product is a motor and intended for industrial use according to this manual.

The product may only be used in compliance with all applicable safety regulations and directives, the specified requirements and the technical data.

Prior to using the product, you must perform a risk assessment in view of the planned application. Based on the results, the appropriate safety measures must be implemented.

Since the product is used as a component in an entire system, you must ensure the safety of persons by means of the design of this entire system (for example, machine design).

Operate the product only with the specified cables and accessories. Use only genuine accessories and spare parts.

The product must NEVER be operated in explosive atmospheres (hazardous locations, Ex areas).

Any use other than the use explicitly permitted is prohibited and can result in hazards.

Electrical equipment should be installed, operated, serviced, and maintained only by qualified personnel.

## 2.3 Hazard categories

Safety instructions to the user are highlighted by safety alert symbols in the manual. In addition, labels with symbols and/or instructions are attached to the product that alert you to potential hazards.

Depending on the seriousness of the hazard, the safety instructions are divided into 4 hazard categories.

### DANGER

DANGER indicates an imminently hazardous situation, which, if not avoided, **will result** in death or serious injury.

### WARNING

WARNING indicates a potentially hazardous situation, which, if not avoided, **can result** in death, serious injury, or equipment damage.

### CAUTION

CAUTION indicates a potentially hazardous situation, which, if not avoided, **can result** in injury or equipment damage.

### CAUTION

CAUTION used without the safety alert symbol, is used to address practices not related to personal injury (e.g. **can result** in equipment damage).



## 2.4 Basic information

### **⚠ DANGER**

#### **HAZARD OF ELECTRIC SHOCK, EXPLOSION OR ARC FLASH**

- Only appropriately trained persons who are familiar with and understand the contents of this manual and all other pertinent product documentation and who have received safety training to recognize and avoid hazards involved are authorized to work on and with this drive system. Installation, adjustment, repair and maintenance must be performed by qualified personnel.
- The system integrator is responsible for compliance with all local and national electrical code requirements as well as all other applicable regulations with respect to grounding of all equipment.
- Supplement the motor cable grounding conductor with an additional protective ground conductor to the motor housing.
- Do not touch unshielded components or terminals with voltage present. Use only electrically insulated tools.
- The motor generates voltage when the shaft is rotated. Prior to performing any type of work on the drive system, block the motor shaft to prevent rotation.
- AC voltage can couple voltage to unused conductors in the motor cable. Insulate both ends of unused conductors in the motor cable.
- Do not short across the DC bus terminals or the DC bus capacitors.
- Before performing work on the drive system:
  - Disconnect all power, including external control power that may be present.
  - Place a "Do Not Turn On" label on all power switches.
  - Lock all power switches in the open position.
  - Wait for the DC bus capacitors to discharge (see the product manual for the power stage). Then measure the DC bus voltage and verify it is less than  $< 42 V_{dc}$  (see the product manual for the power stage).
- Install and close all covers before applying voltage.

**Failure to follow these instructions will result in death or serious injury.**

**▲ WARNING****MOVEMENT WITHOUT BRAKING EFFECT**

If power outage or errors cause the power stage to be switched off, the motor is no longer decelerated in a controlled way and may cause damage. Overload or errors can cause hazards due to the failure of the holding brake. Incorrect use of the holding brake results in premature wear and failure.

- Secure the hazardous area so it cannot be accessed.
- Verify the function of the holding brake at regular intervals.
- Do not use the holding brake as a service brake.
- If necessary, use a cushioned mechanical stop or a suitable service brake.

**Failure to follow these instructions can result in death, serious injury or equipment damage.**

**▲ WARNING****LOSS OF CONTROL**

- The designer of any control scheme must consider the potential failure modes of control paths and, for certain critical functions, provide a means to achieve a safe state during and after a path failure. Examples of critical control functions are emergency stop, overtravel stop, power outage and restart.
- Separate or redundant control paths must be provided for critical functions.
- System control paths may include communication links. Consideration must be given to the implication of unanticipated transmission delays or failures of the link.
- Observe all accident prevention regulations and local safety guidelines.<sup>1)</sup>
- Each implementation of the product must be individually and thoroughly tested for proper operation before being placed into service.

**Failure to follow these instructions can result in death or serious injury.**

1) For USA: Additional information, refer to NEMA ICS 1.1 (latest edition), "Safety Guidelines for the Application, Installation, and Maintenance of Solid State Control" and to NEMA ICS 7.1 (latest edition), "Safety Standards for Construction and Guide for Selection, Installation and Operation of Adjustable-Speed Drive Systems".

## 2.5 Standards and terminology

Technical terms, terminology and the corresponding descriptions in this manual are intended to use the terms or definitions of the pertinent standards.

In the area of drive systems, this includes, but is not limited to, terms such as "safety function", "safe state", "fault", "fault reset", "failure", "error", "error message", "warning", "warning message", etc.

Among others, these standards include:

- IEC 61800 series: "Adjustable speed electrical power drive systems"
- IEC 61158 series: "Industrial communication networks - Fieldbus specifications"
- IEC 61784 series: "Industrial communication networks - Profiles"
- IEC 61508 series: "Functional safety of electrical/electronic/programmable electronic safety-related systems"

Also see the glossary at the end of this manual.



## 3 Technical Data

# 3

This chapter contains information on the ambient conditions and on the mechanical and electrical properties of the product family and the accessories.

### 3.1 General features

Motor type	3-phase stepper motors	
Degree of protection	See chapter 3.4 "IP degree of protection".	As per IEC 60034-5
Thermal class	155	As per IEC 60034-1
Vibration grade	A	As per IEC 60034-14
Test voltage		As per IEC 60034-1
Shaft wobble / perpendicularity		As per IEC 60072-1, DIN 42955
Housing color	Black RAL 9005	
Overvoltage category	III	As per IEC 61800-5-1
Protection class <sup>1)</sup>	I	As per IEC 61140, EN 50178

1) The signals of the holding brake at CN1 and the signals at CN2 meet the PELV requirements.

### 3.2 Ambient conditions

#### *Climatic environmental conditions transportation and storage*

The environment during transportation and storage must be dry and free from dust. The maximum vibration and shock load must be within the specified limits.

The storage time is primarily determined by the service life of the lubricants in the bearings; do not store the product for more than 36 months. It is recommended to periodically operate the motor.

The following relative humidity is permissible during transportation and storage:

Transportation and Storage temperature	[°C]	-25 ... +70
--	------	-------------

#### *Vibration and shock*

Vibration, sinusoidal	Type test with 10 runs as per IEC 60068-2-6 0.15 mm (from 10 Hz ... 60 Hz) 20 m/s <sup>2</sup> (from 60 Hz ... 500 Hz)
Shock, semi-sinusoidal	Type test with 3 shocks in each direction as per IEC 60068-2-27 150 m/s <sup>2</sup> (11 ms)

#### *Climatic environmental conditions operation*

Ambient temperature <sup>1)</sup> (no icing)	[°C]	-25 ... +40
---	------	-------------

1) Limit values with flanged motor (for example, steel plate 300 x 300 x 10 mm)

The following relative humidity is permissible during operation:

Relative humidity (non-condensing)	[%]	75 (annual mean) 95 (on 30 days)
---------------------------------------	-----	-------------------------------------

The installation altitude is defined as altitude above mean sea level.

Installation altitude without derating	[m]	< 1000
--	-----	--------

Maximum angular acceleration	[rad/s <sup>2</sup> ]	200000
------------------------------	-----------------------	--------

### 3.3 Service life

The service life of the motors when operated correctly is limited primarily by the bearing service life.

The following operating conditions can significantly reduce the service life:

- Installation altitude more than 1000 m above m.s.l.
- Continuous operating temperatures greater than 80 °C
- Movements of less than 100 °
- Operation with very high angular acceleration
- Operation under vibration load greater than 20 m/s<sup>2</sup>
- High cycle frequencies
- Allowing sealing rings to run dry
- Contact of the motor with aggressive media
- Condensation and icing
- Exceeding the permissible shaft load

### 3.4 IP degree of protection

The motors have the following degrees of protection as per EN 60034-5:

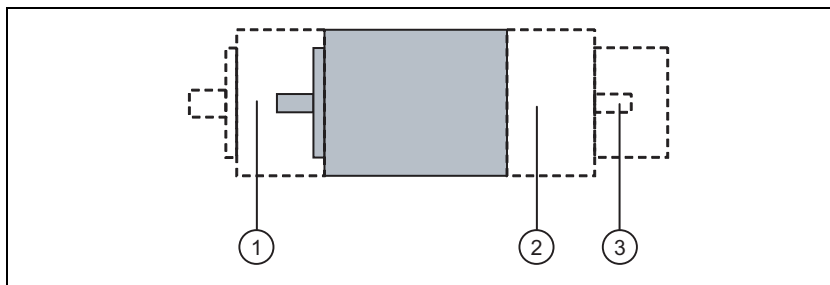

Figure 3.1 IP degree of protection

Item		Degree of protection
1	Shaft bushing without shaft sealing ring	IP 41
	Shaft bushing with shaft sealing ring <sup>1)</sup>	IP 56
	Shaft bushing with GBX gearbox	IP 54
2	Motor connection	IP 56
3	Shaft bushing second shaft end	IP 41
	Rear side of motor with holding brake or encoder	IP 56

1) Optional in case of BRS39

The total degree of protection is determined by the component with the lowest degree of protection.

#### *Shaft sealing ring*

A motor version with a shaft sealing ring is available so that has degree of protection IP56. In the case of motor versions with shaft sealing ring, the maximum speed of rotation must be limited to 3000 min<sup>-1</sup>.

Note the following:

- The shaft sealing ring is factory-pre-lubricated.
- If the seals run dry, this increases friction and greatly reduces the service life of the sealing rings.
- In the case of mounting position IM V3 (drive shaft vertical, shaft end upward), the motor only has degree of protection IP 41.



### 3.5 Motor-specific data

#### 3.5.1 Motor-specific data BRS36

Motor type		BRS364		BRS366			BRS368			
Winding		F	H	F	H	N	F	H	N	W
Maximum supply voltage $U_{\max}$	$V_{\text{ac}}$	34	25	34	25	92	34	25	92	230
Maximum voltage to ground	$V_{\text{ac}}$	42	42	42	42	125	42	42	125	250
Nominal voltage DC bus $U_{\text{N}}$	$V_{\text{dc}}$	24/36/ 48	24/36/ 48	24/36/ 48	24/36/ 48	130	24/36/ 48	24/36/ 48	130	325
Nominal torque $M_{\text{N}}$	Nm	0.4	0.45	0.8	0.90	0.90	1.3	1.50	1.50	1.50
Holding torque $M_{\text{H}}$	Nm	0.45	0.51	0.9	1.02	1.02	1.5	1.70	1.70	1.70
Rotor inertia $J_{\text{R}}$	kgcm <sup>2</sup>	0.1	0.1	0.22	0.22	0.22	0.38	0.38	0.38	0.38
Steps per revolution <sup>1)</sup>		200 / 400 / 500 / 1000 / 2000 / 4000 / 5000 / 10000								
Step angle $\alpha$	°	1.8 / 0.9 / 0.72 / 0.36 / 0.18 / 0.09 / 0.072 / 0.036								
Systematic angle tolerance $\Delta\alpha_{\text{s}}$ <sup>2)</sup>	'	±6	±6	±6	±6	±6	±6	±6	±6	±6
Maximum starting frequency $f_{\text{Aom}}$	kHz	7.2	8.5	7.1	8.0	8.5	6.4	6.0	8.5	8.5
Motor phase current $I_{\text{N}}$	$A_{\text{rms}}$	6.6	5.2	7.0	5.8	1.6	7	5.8	1.9	0.9
Winding resistance $R_{\text{W}}$	$\Omega$	0.24	0.42	0.32	0.46	3.3	0.46	0.7	4.8	25
Electrical time constant $t$ typical	ms	1.9	2.1	2.6	3.3	3.3	2.9	4.6	4.6	4.6
Mass $m$ <sup>3)</sup>	kg	0.7	0.7	0.95	0.95	0.95	1.3	1.3	1.3	1.3

1) Depends on control

2) Measured at 1000 steps/revolution, unit: minute of arc

3) Mass of motor version with cable gland and connector without holding brake

## 3.5.2 Motor-specific data BRS39

Motor type		BRS397				BRS39A			
Winding		F	H	N	W	F	H	N	W
Maximum supply voltage $U_{max}$	$V_{ac}$	34	25	92	230	34	25	92	230
Maximum voltage to ground	$V_{ac}$	42	42	125	250	42	42	125	250
Nominal voltage DC bus $U_N$	$V_{dc}$	24/36/48	24/36/48	130	325	24/36/48	24/36/48	130	325
Nominal torque $M_N$	Nm	1.85	1.7	2	2	3.4	3.7	4	4
Holding torque $M_H$	Nm	2.1	1.92	2.26	2.26	3.8	4.18	4.52	4.52
Rotor inertia $J_R$	kgcm <sup>2</sup>	1.1	1.1	1.1	1.1	2.2	2.2	2.2	2.2
Steps per revolution <sup>1)</sup>		200 / 400 / 500 / 1000 / 2000 / 4000 / 5000 / 10000							
Step angle $\alpha$	°	1.8 / 0.9 / 0.72 / 0.36 / 0.18 / 0.09 / 0.072 / 0.036							
Systematic angle tolerance $\Delta\alpha_s$ <sup>2)</sup>	'	±6	±6	±6	±6	±6	±6	±6	±6
Maximum starting frequency $f_{Aom}$	kHz	4.8	4.6	5.3	5.3	4.7	4.8	5.3	5.3
Motor phase current $I_N$	$A_{rms}$	9.5	5.8	4.4	1.75	8.5	5.8	5	2
Winding resistance $R_W$	$\Omega$	0.24	0.35	1	6.5	0.36	0.55	1.2	5.8
Electrical time constant t typical	ms	4	7	7	7	5	9	9	9
Mass $m$ <sup>3)</sup>	kg	2.1	2.1	2.1	2.1	3.2	3.2	3.2	3.2

1) Depends on control

2) Measured at 1000 steps/revolution, unit: minute of arc

3) Mass of motor version with cable gland and connector without holding brake

Motor type		BRS39B			
Winding		F	H	N	W
Maximum supply voltage $U_{max}$	$V_{ac}$	34	25	92	230
Maximum voltage to ground	$V_{ac}$	42	42	125	250
Nominal voltage DC bus $U_N$	$V_{dc}$	24/36/48	24/36/48	130	325
Nominal torque $M_N$	Nm	4.8	5	6	6
Holding torque $M_H$	Nm	5.4	5.65	6.78	6.78
Rotor inertia $J_R$	kgcm <sup>2</sup>	3.3	3.3	3.3	3.3
Steps per revolution <sup>1)</sup>		200 / 400 / 500 / 1000 / 2000 / 4000 / 5000 / 10000			
Step angle $\alpha$	°	1.8 / 0.9 / 0.72 / 0.36 / 0.18 / 0.09 / 0.072 / 0.036			
Systematic angle tolerance $\Delta\alpha_s$ <sup>2)</sup>	'	±6	±6	±6	±6
Maximum starting frequency $f_{Aom}$	kHz	4.6	4.5	5.3	5.3
Motor phase current $I_N$	$A_{rms}$	8.5	5.8	5	2.25
Winding resistance $R_W$	$\Omega$	0.48	0.63	1.3	6.5
Electrical time constant t typical	ms	6	10	10	10
Mass $m$ <sup>3)</sup>	kg	4.3	4.3	4.3	4.3

1) Depends on control

2) Measured at 1000 steps/revolution, unit: minute of arc

3) Mass of motor version with cable gland and connector without holding brake

## 3.5.3 Motor-specific data BRS3A

Motor type		BRS3AC	BRS3AD
<b>Winding</b>		<b>W</b>	<b>W</b>
Maximum supply voltage $U_{\max}$	$V_{ac}$	230	230
Maximum voltage to ground	$V_{ac}$	250	250
Nominal voltage DC bus $U_N$	$V_{dc}$	325	325
Nominal torque $M_N$	Nm	12	16.5
Holding torque $M_H$	Nm	13.5	19.7
Rotor inertia $J_R$	kgcm <sup>2</sup>	10.5	16
Steps per revolution <sup>1)</sup>		200 / 400 / 500 / 1000 / 2000 / 4000 / 5000 / 10000	
Step angle $\alpha$	°	1.8 / 0.9 / 0.72 / 0.36 / 0.18 / 0.09 / 0.072 / 0.036	
Systematic angle tolerance $\Delta\alpha_s$ <sup>2)</sup>	'	±6	±6
Maximum starting frequency $f_{Aom}$	kHz	4.7	4.7
Motor phase current $I_N$	$A_{rms}$	4.1	4.75
Winding resistance $R_W$	$\Omega$	1.8	1.9
Electrical time constant t typical	ms	22	22
Mass $m$ <sup>3)</sup>	kg	8.2	11.2

1) Depends on control

2) Measured at 1000 steps/revolution, unit: minute of arc

3) Mass of motor version with cable gland and connector without holding brake

### 3.6 Characteristic curves

#### 3.6.1 Characteristic curves BRS36

##### 3.6.1.1 Characteristic curves BRS364

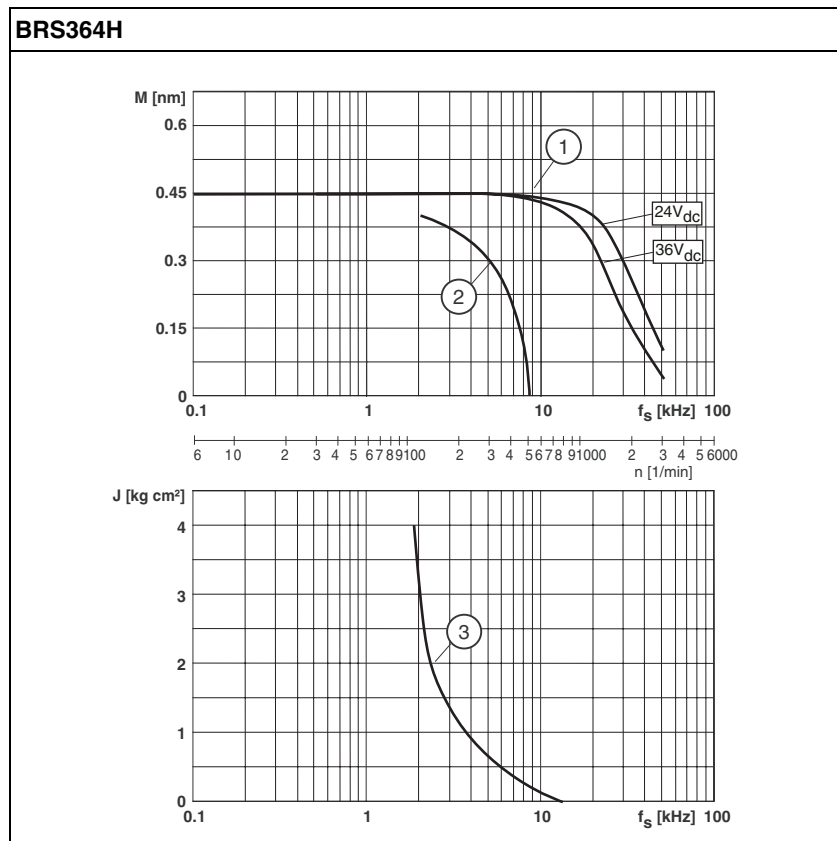

Measurement of characteristic curves with 1000 steps/revolution, nominal voltage  $U_N$  and nominal current  $I_N$

- (1) Pull-out torque
- (2) Pull-in torque
- (3) Maximum load inertia

3.6.1.2 Characteristic curves BRS366

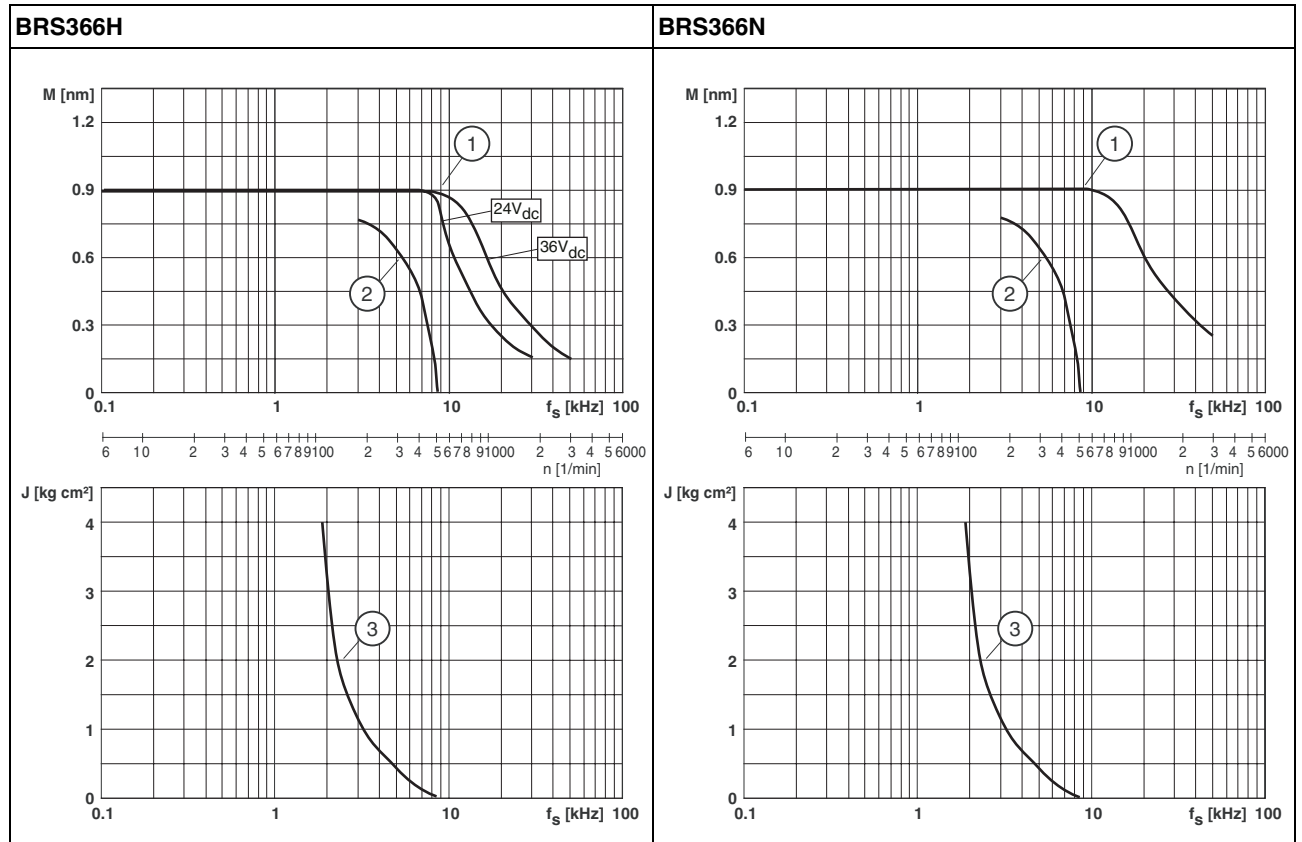

Measurement of characteristic curves with 1000 steps/revolution, nominal voltage  $U_N$  and nominal current  $I_N$

- (1) Pull-out torque
- (2) Pull-in torque
- (3) Maximum load inertia

3.6.1.3 Characteristic curves BRS368

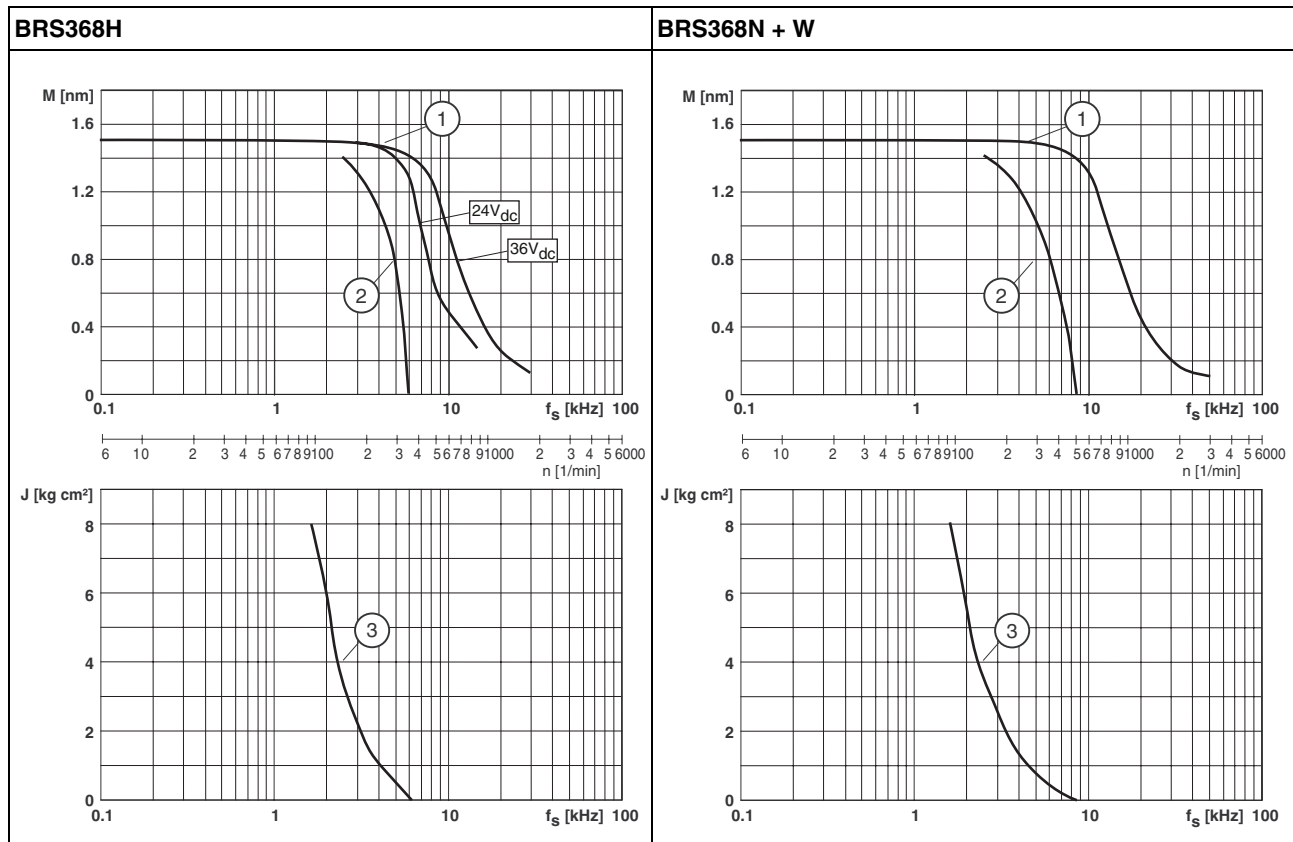

Measurement of characteristic curves with 1000 steps/revolution, nominal voltage  $U_N$  and nominal current  $I_N$

- (1) Pull-out torque
- (2) Pull-in torque
- (3) Maximum load inertia

3.6.2 Characteristic curves BRS39

3.6.2.1 Characteristic curves BRS397

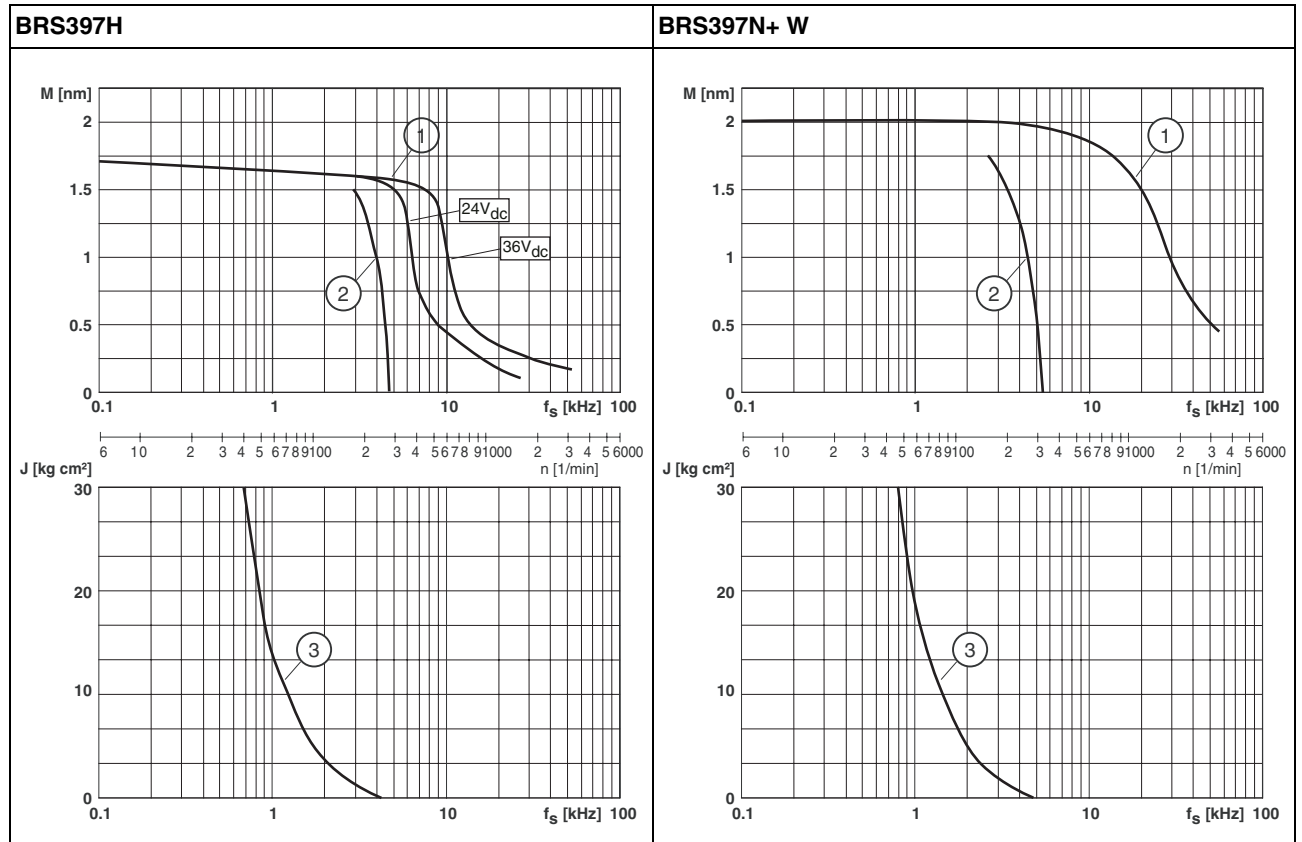

Measurement of characteristic curves with 1000 steps/revolution, nominal voltage  $U_N$  and nominal current  $I_N$

- (1) Pull-out torque
- (2) Pull-in torque
- (3) Maximum load inertia

3.6.2.2 Characteristic curves BRS39A

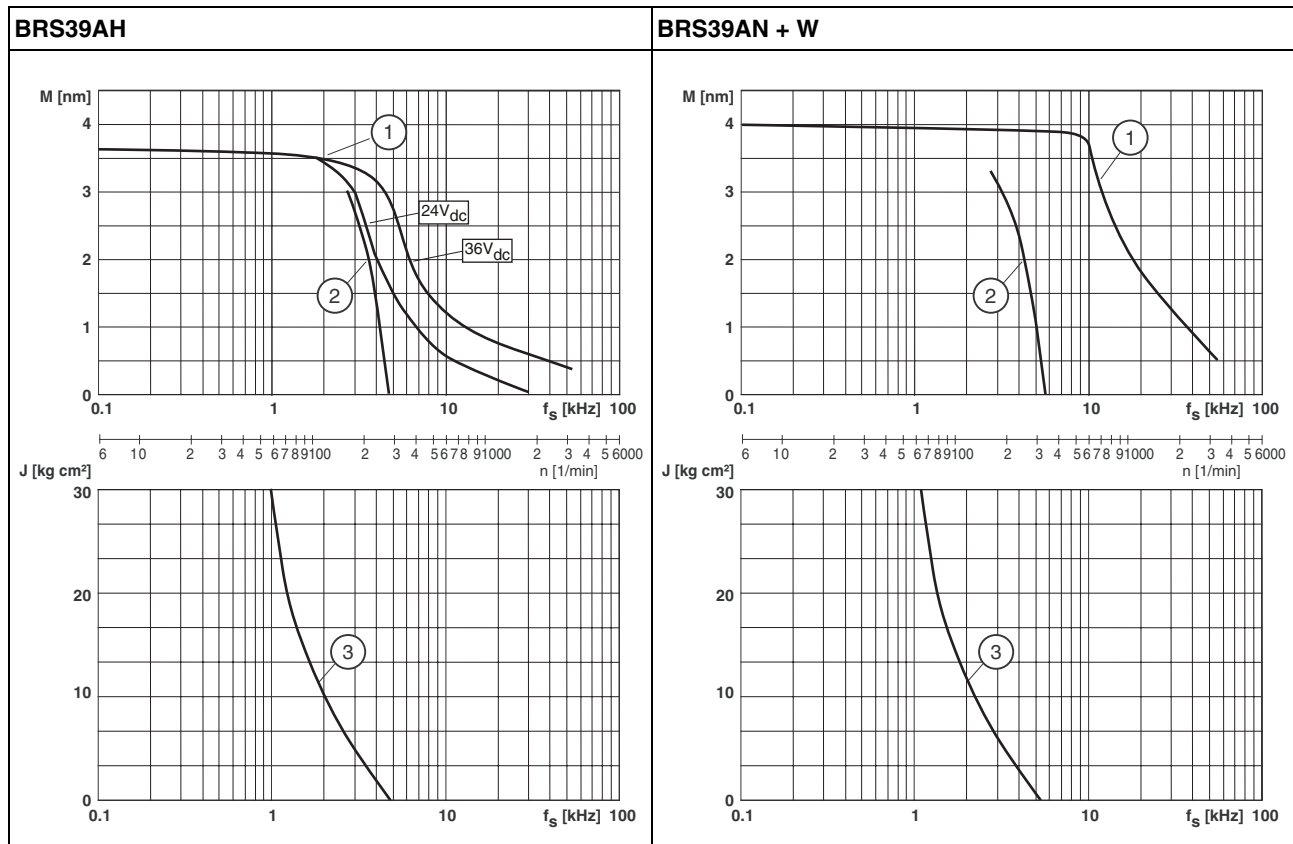

Measurement of characteristic curves with 1000 steps/revolution, nominal voltage  $U_N$  and nominal current  $I_N$

- (1) Pull-out torque
- (2) Pull-in torque
- (3) Maximum load inertia



3.6.2.3 Characteristic curves BRS39B

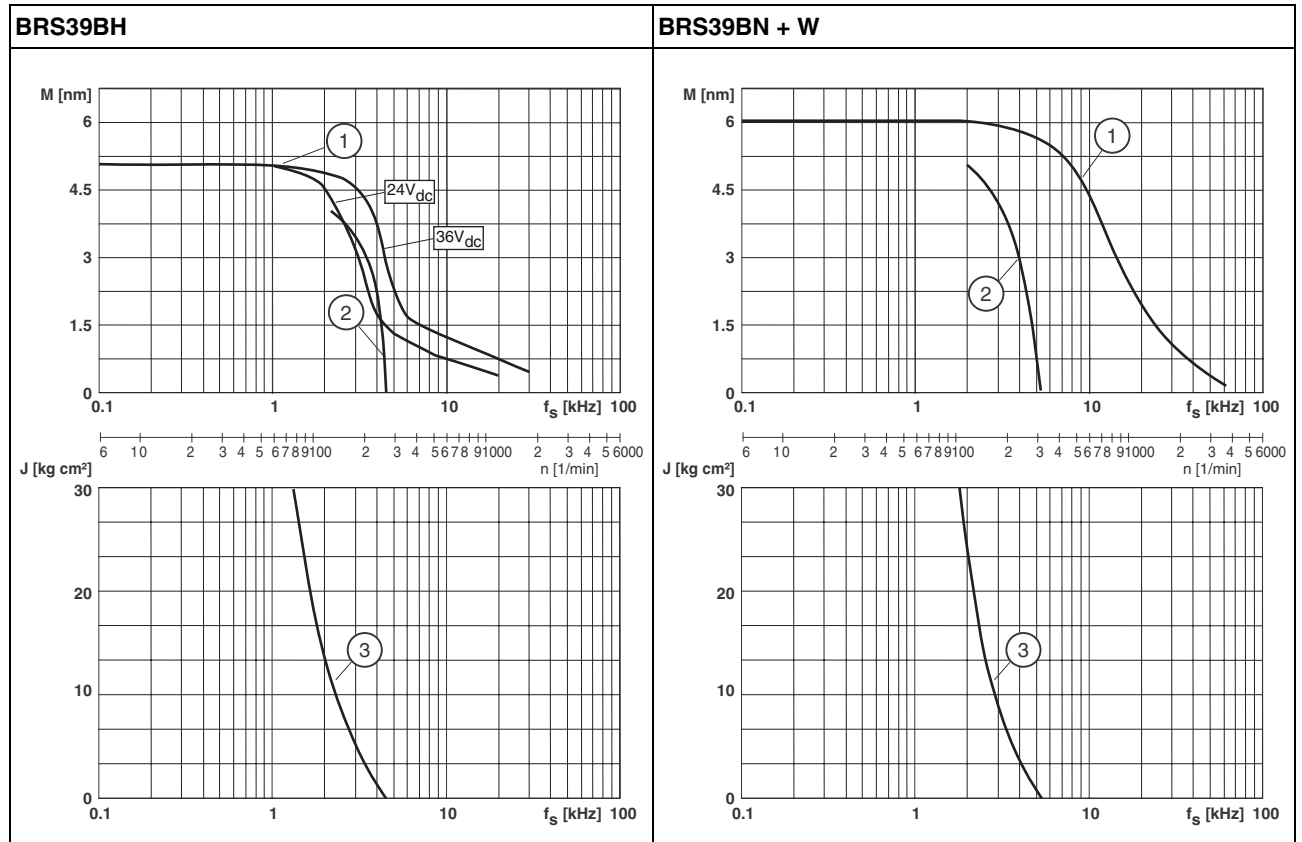

Measurement of characteristic curves with 1000 steps/revolution, nominal voltage  $U_N$  and nominal current  $I_N$

- (1) Pull-out torque
- (2) Pull-in torque
- (3) Maximum load inertia

3.6.3 Characteristic curves BRS3A

3.6.3.1 Characteristic curves BRS3AC

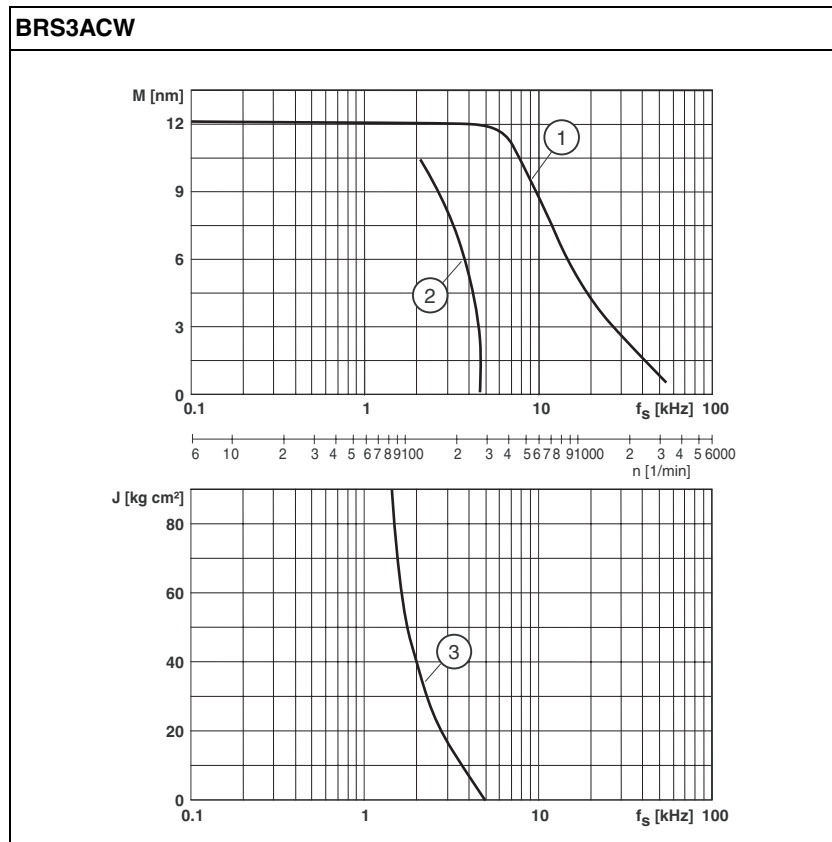

Measurement of characteristic curves with 1000 steps/revolution, nominal voltage  $U_N$  and nominal current  $I_N$

- (1) Pull-out torque
- (2) Pull-in torque
- (3) Maximum load inertia

3.6.3.2 Characteristic curves BRS3AD

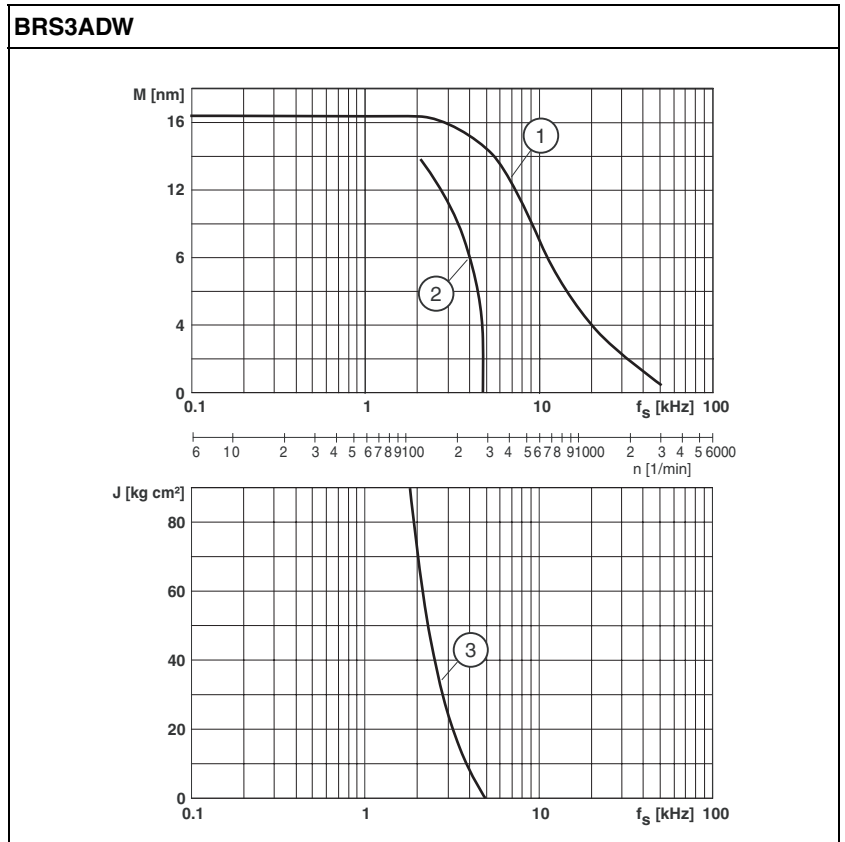

Measurement of characteristic curves with 1000 steps/revolution, nominal voltage  $U_N$  and nominal current  $I_N$

- (1) Pull-out torque
- (2) Pull-in torque
- (3) Maximum load inertia

3.7 Dimensions

3.7.1 Dimensional drawing BRS36

The following applies to the dimensional drawings below:

(1) Motor with holding brake

		L	D
BRS364	[mm]	42	6.35
BRS366	[mm]	56	6.35
BRS368	[mm]	79	8

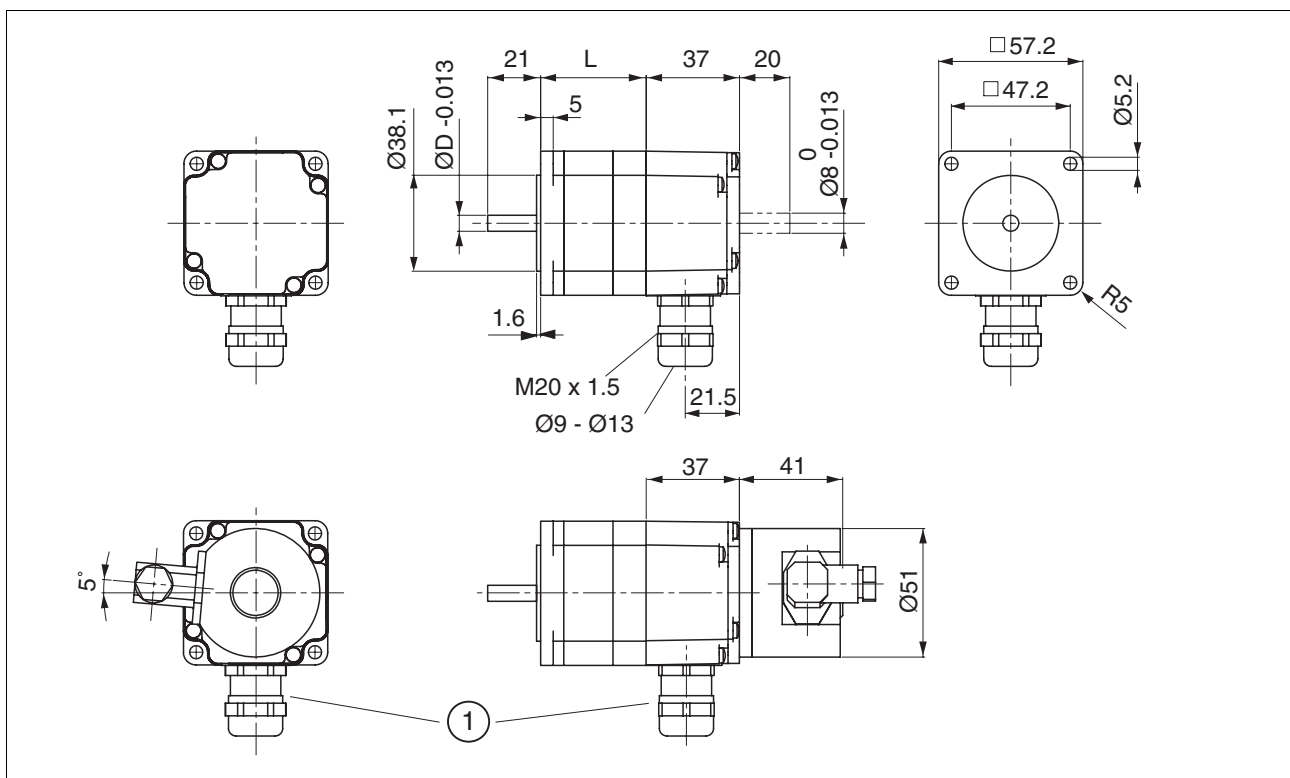

Figure 3.2 BRS36 dimensional drawing terminal version

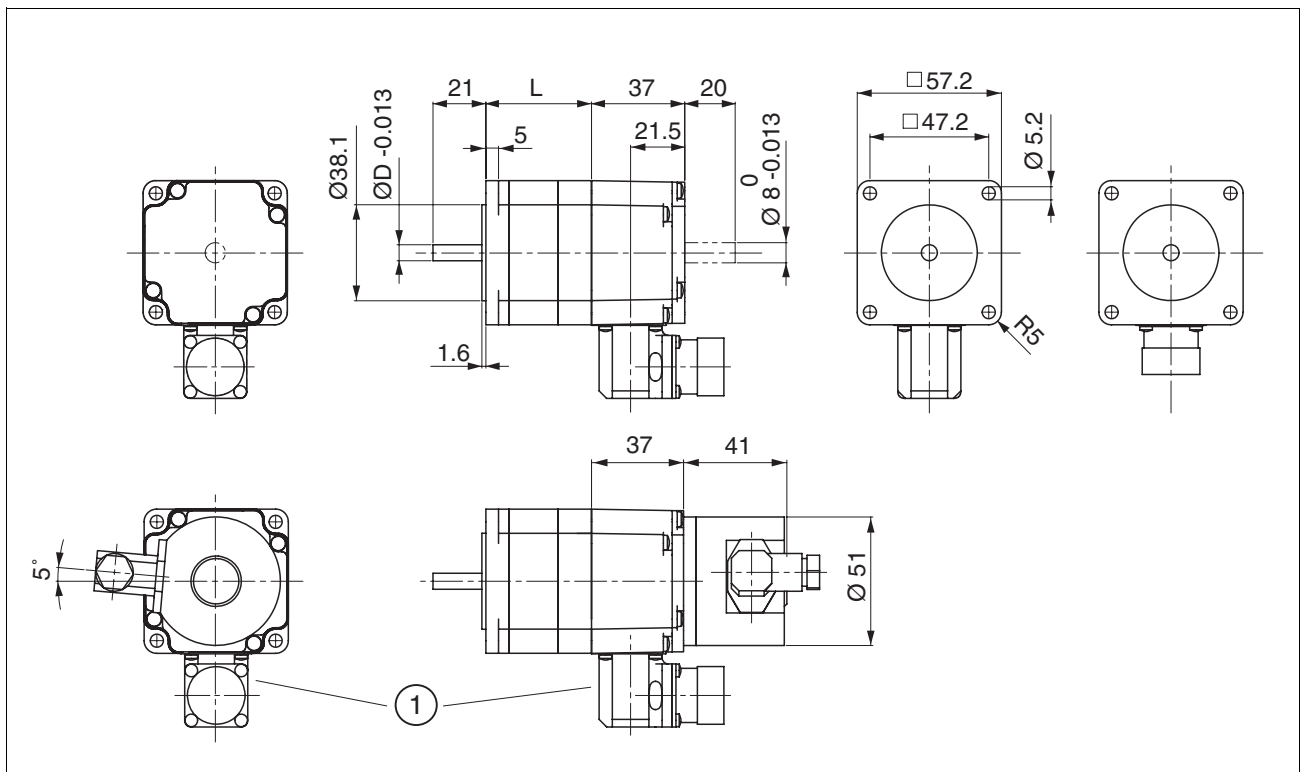

Figure 3.3 BRS36 dimensional drawing connector version without encoder

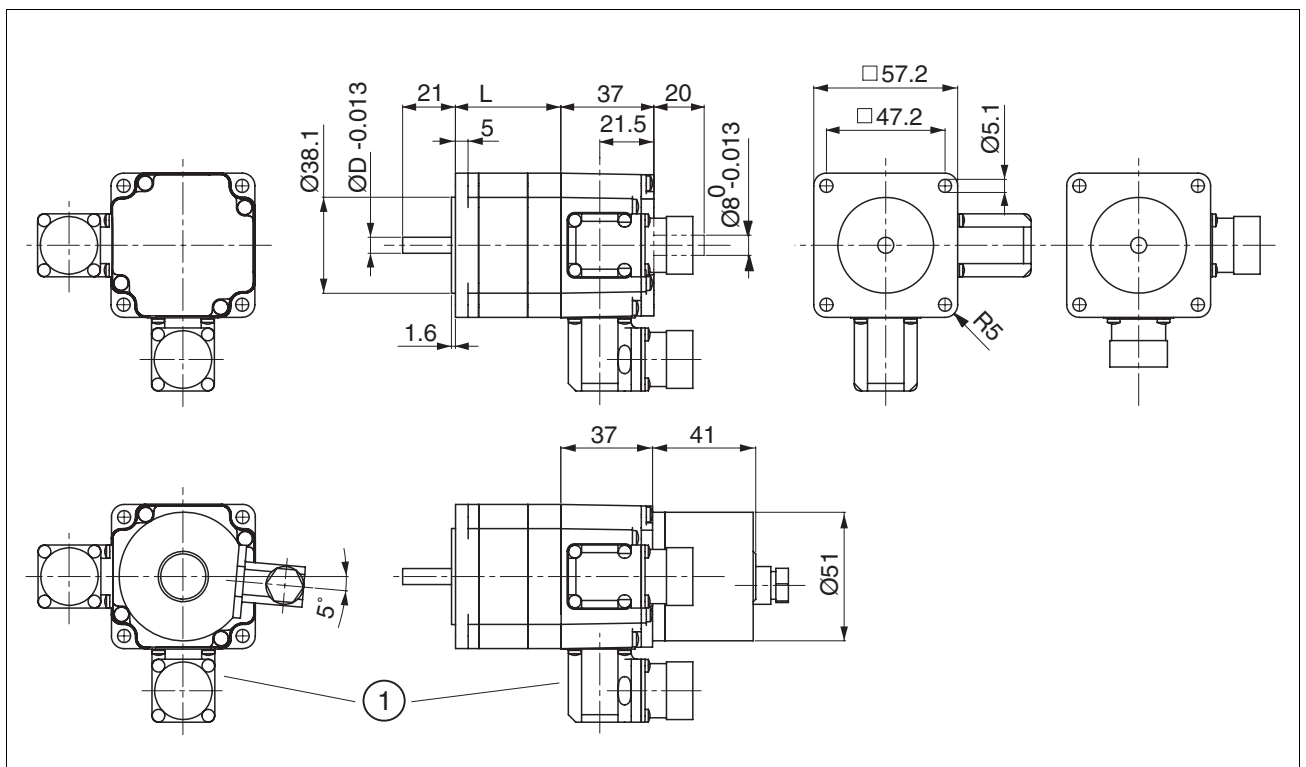

Figure 3.4 BRS36 dimensional drawing connector version with encoder

3.7.2 Dimensional drawing BRS39

The following applies to the dimensional drawings below:

- (1) Motor with holding brake
- (2) Woodruff key

BRS ••		•• 397		•• 39A		•• 39B
L	[mm]	67.5		97.5		127.5
Tolerance		+0.6 / -0.8		+0.6 / -0.8		+0.6 / -0.8
D	[mm]	9.5	12	9.5	12	14
Woodruff key as per DIN 6888	[mm]	3 x 5	4 x 6.5	3 x 5	4 x 6.5	4 x 6.5
N	[mm]	60	73	60	73	60 / 73

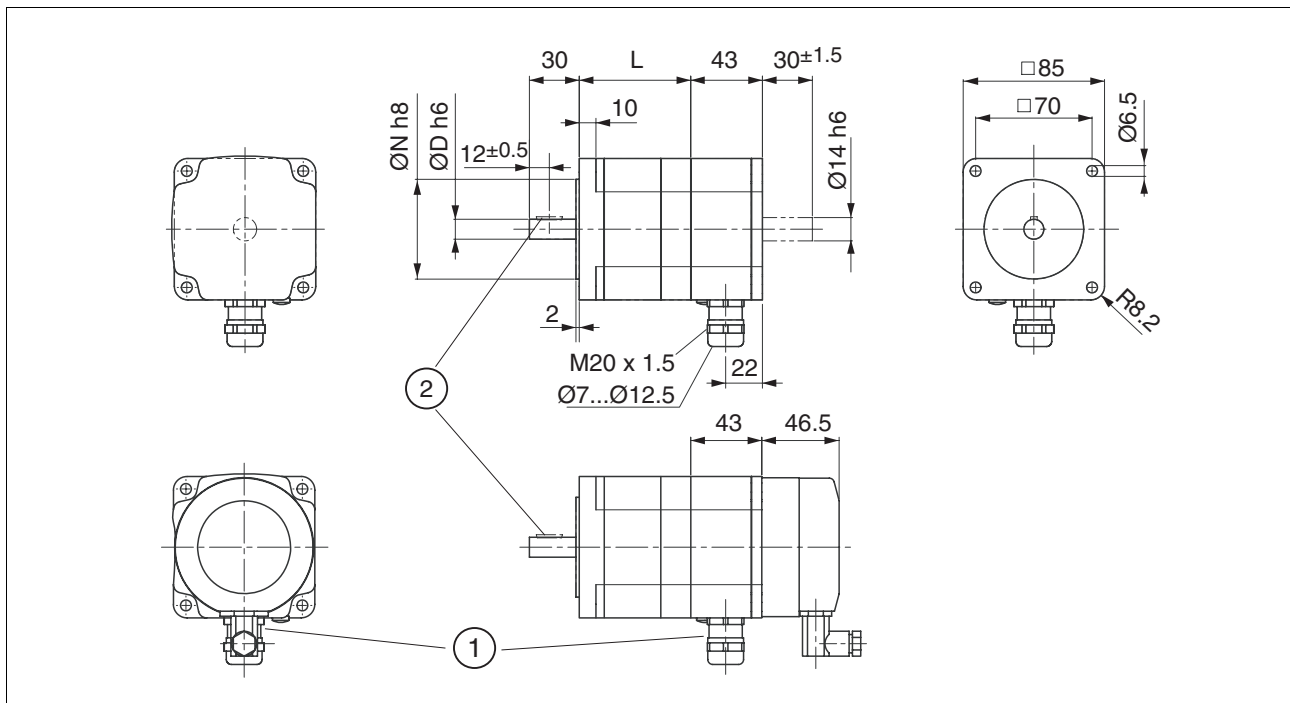

Figure 3.5 BRS39 dimensional drawing terminal version

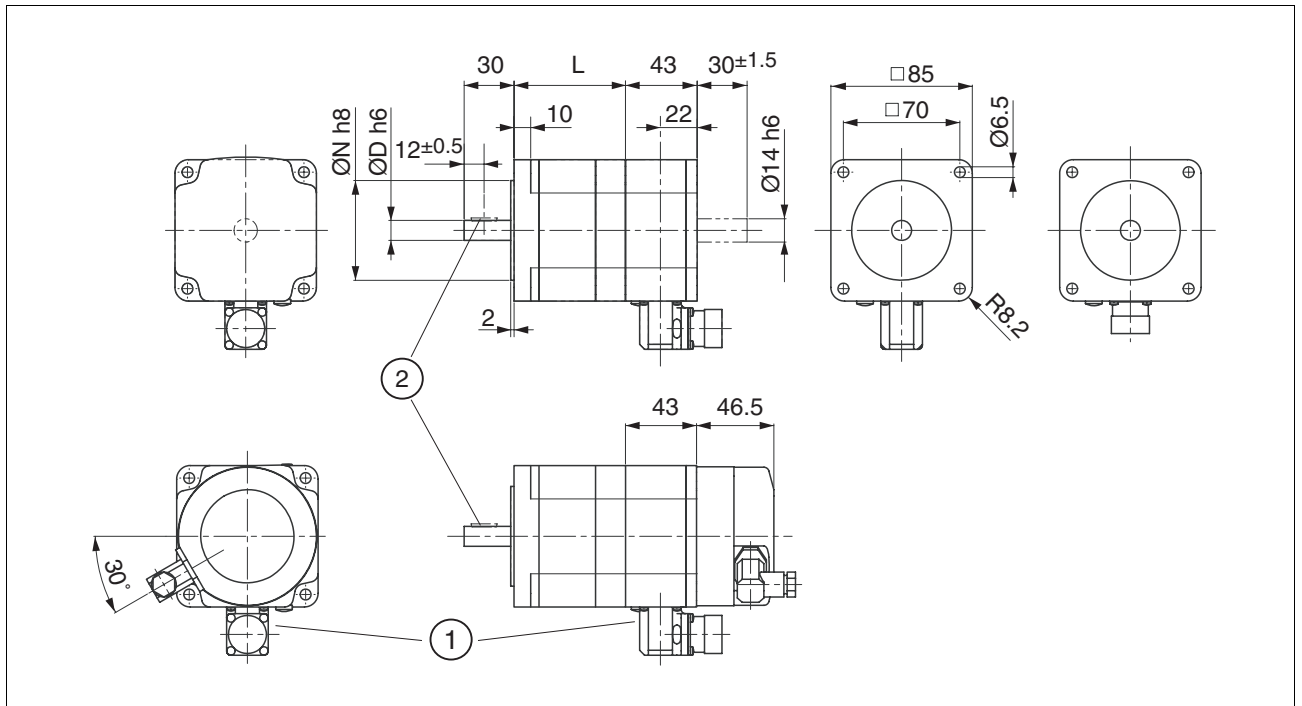

Figure 3.6 BRS39 dimensional drawing connector version without encoder

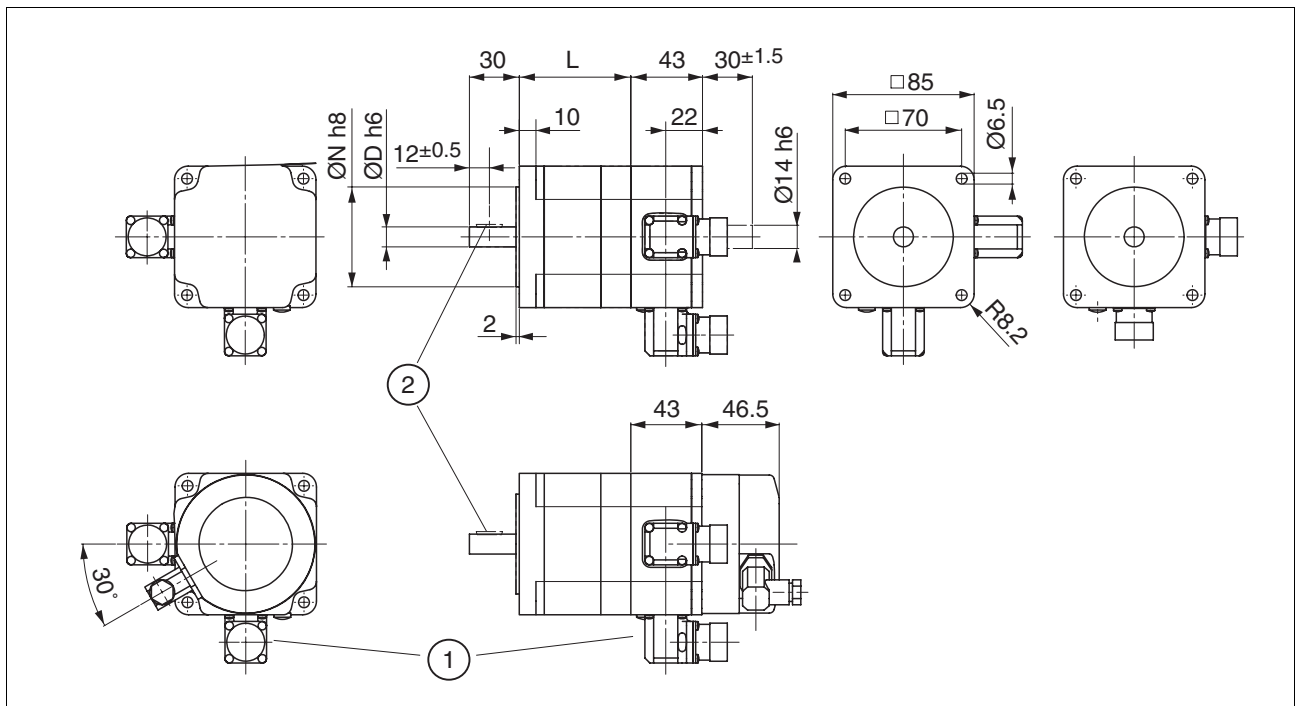

Figure 3.7 BRS39 dimensional drawing connector version with encoder

3.7.3 Dimensional drawing BRS3A

The following applies to the dimensional drawings below:

- (1) Motor with holding brake
- (2) Parallel key

BRS ••		•• 3AC	•• 3AD
L	[mm]	180	228
Tolerance		±1	±1
Parallel key as per DIN 6885		A6x6x25	A6x6x25

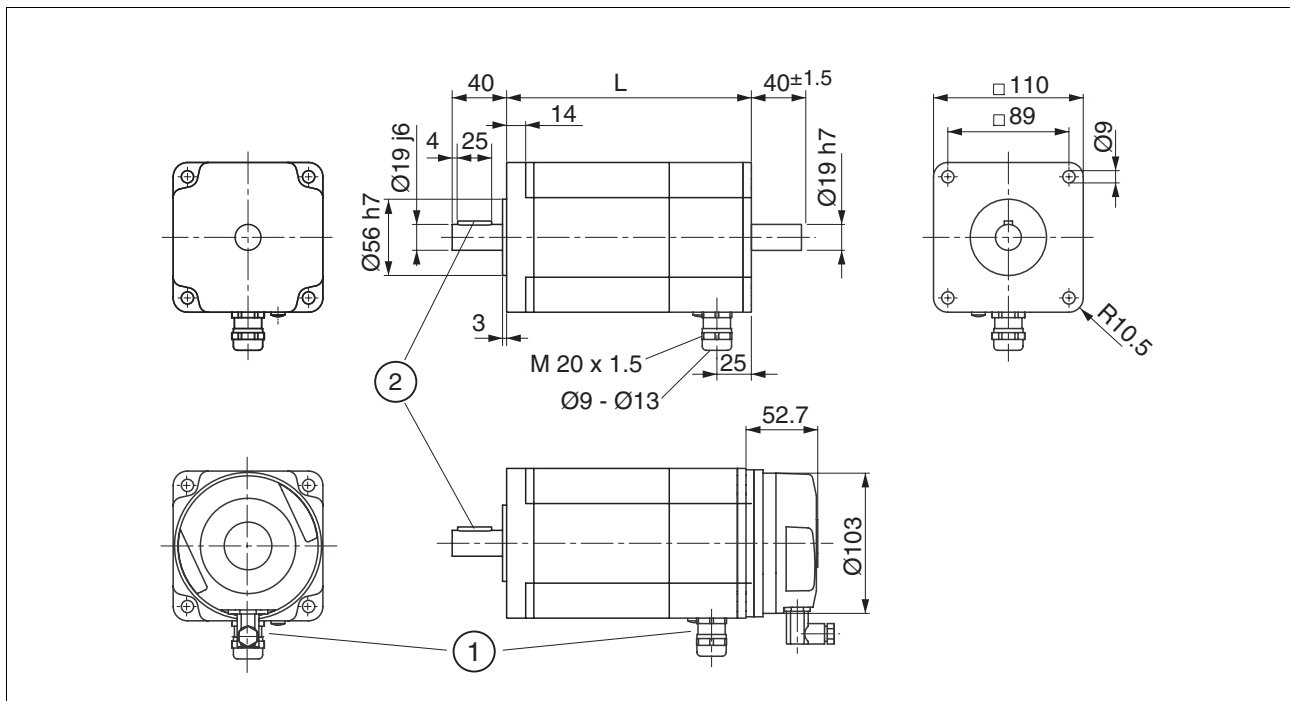

Figure 3.8 BRS3A dimensional drawing terminal version



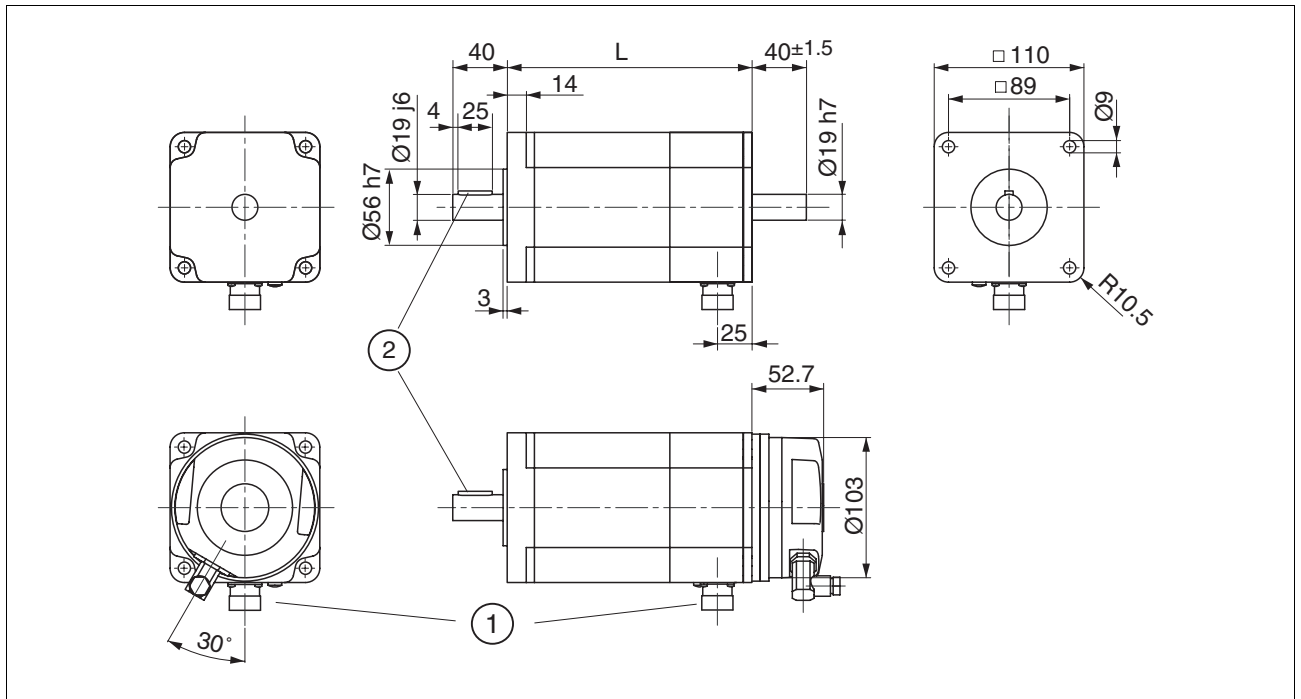

Figure 3.9 BRS3A dimensional drawing connector version without encoder

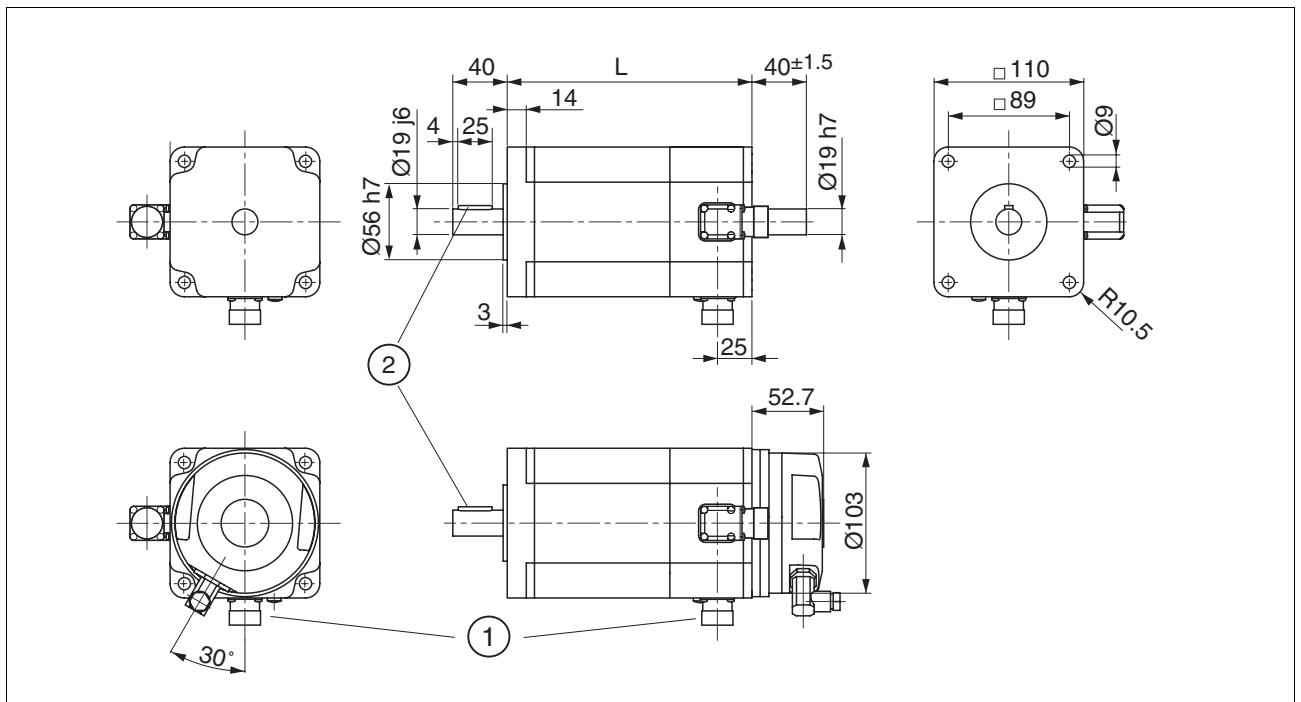

Figure 3.10 BRS3A dimensional drawing connector version with encoder

### 3.8 Shaft-specific data

#### 3.8.1 Force for pressing on

#### **⚠ WARNING**

##### **UNINTENDED BEHAVIOR CAUSED BY MECHANICAL DAMAGE TO THE MOTOR**

If the maximum permissible forces at the shaft are exceeded, this will result in premature wear of the bearing, shaft breakage or damage to the encoder.

- Do not exceed the maximum permissible axial and radial forces.
- Protect the shaft from impact.
- Do not exceed the maximum permissible axial force when pressing on components.

**Failure to follow these instructions can result in death, serious injury or equipment damage.**

##### *Maximum force during pressing on*

The force applied during pressing on must not exceed the maximum permissible axial force that may act on the rolling bearing, see chapter 3.8.2 "Shaft load". Applying assembly paste (such as Klüberpaste 46 MR 401) to the shaft and the component to be mounted reduces friction and mechanical impact on the surfaces.

If the shaft has a thread, it is recommended to use it to press on the component to be mounted. This way there is no axial force acting on the rolling bearing.

It is also possible to shrink-fit, clamp or glue the component to be mounted.

### 3.8.2 Shaft load

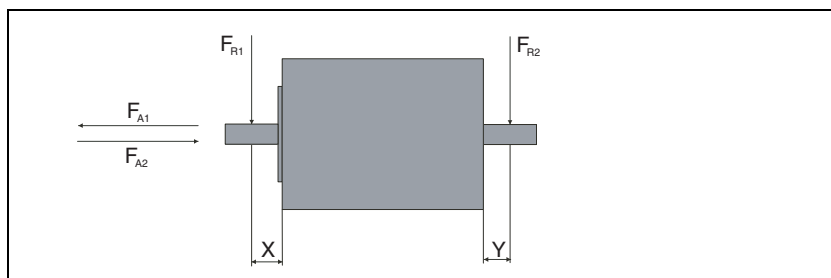

The following conditions apply:

- Speed of rotation  $n = 600 \text{ min}^{-1}$
- Ambient temperature =  $40^\circ\text{C}$  (approx.  $80^\circ\text{C}$  bearing temperature)
- 100% duty cycle at nominal torque

If these conditions are met the maximum forces shown in the table below may act on the shaft (however, not simultaneously):

#### 3.8.2.1 Shaft load BRS36x

Motor type		BRS364	BRS366	BRS368
Maximum radial force 1st shaft end $F_{R1}$ <sup>1)</sup>	N	24	24	50
Maximum radial force 2nd shaft end (optional) $F_{R2}$ <sup>1)</sup>	N	25 / 40 <sup>2)</sup>	25 / 40 <sup>2)</sup>	25 / 40 <sup>2)</sup>
Maximum axial force tension $F_{A1}$	N	100	100	100
Maximum axial force compression $F_{A2}$	N	8.4	8.4	8.4
Nominal bearing service life $L_{10h}$ <sup>3)</sup>	h	20000	20000	20000

1) Point of application of radial force:  $X = Y = 10 \text{ mm}$  distance from flange

2) Value 1: motors with terminal box, connector or encoder; value 2: flying leads version

3) Operating hours at a probability of failure of 10%

#### 3.8.2.2 Shaft load BRS39x

Motor type		BRS397	BRS39A	BRS39B
Maximum radial force 1st shaft end $F_{R1}$ <sup>1)</sup>	N	100	100	110
Maximum radial force 2nd shaft end (optional) $F_{R2}$ <sup>1)</sup>	N	50 / 75 <sup>2)</sup>	50 / 75 <sup>2)</sup>	50 / 75 <sup>2)</sup>
Maximum axial force tension $F_{A1}$	N	175	175	175
Maximum axial force compression $F_{A2}$	N	30	30	30
Nominal bearing service life $L_{10h}$ <sup>3)</sup>	h	20000	20000	20000

1) Point of application of radial force:  $X = Y = 15 \text{ mm}$  distance from flange

2) Value 1: motors with terminal box, connector or encoder; value 2: flying leads version

3) Operating hours at a probability of failure of 10%

## 3.8.2.3 Shaft load BRS3Ax

Motor type		BRS3AC	BRS3AD
Maximum radial force 1st shaft end $F_{R1}$ <sup>1)</sup>	N	300	300
Maximum radial force 2nd shaft end (optional) $F_{R2}$ <sup>1)</sup>	N	150	150
Maximum axial force tension $F_{A1}$	N	330	330
Maximum axial force compression $F_{A2}$	N	60	60
Nominal bearing service life $L_{10h}$ <sup>2)</sup>	h	20000	20000

1) Point of application of radial force:  $X = Y = 20$  mm distance from flange

2) Operating hours at a probability of failure of 10%

### 3.9 Motor versions

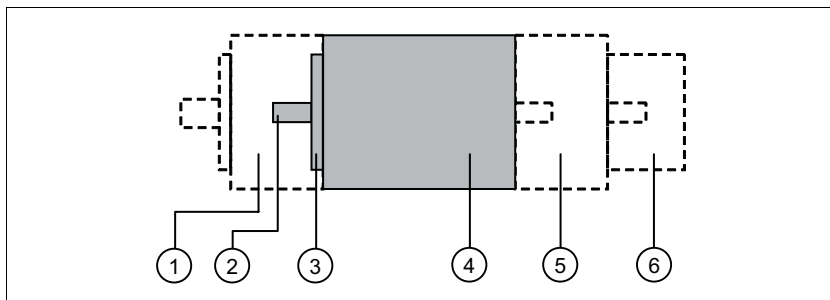

Figure 3.11 Motor versions

Item	BRS ●●	●● 36	●● 39	●● 3A
1	GBX gearbox (accessory)	See catalog	See catalog	See catalog
2	Shaft diameter	6.35 mm 8 mm	9.5 mm 12 mm 14 mm	19 mm
3	Centering collar	38.1 mm	60 mm 73 mm	56 mm
4	Size	57.2 mm	85 mm	110 mm
4	Length	42 mm 56 mm 79 mm	68 mm 98 mm 128 mm	180 mm 230 mm
4	Winding	H, N, (W)	H, N, W	H, N, W
5	Motor connection	Flying leads version Terminal box <sup>1)</sup> Connector	Flying leads version Terminal box <sup>1)</sup> Connector	Terminal box <sup>1)</sup> Connector
6	Options	2nd shaft end <sup>2)</sup> Holding brake Encoder <sup>3)</sup>	2nd shaft end <sup>2)</sup> Holding brake Encoder <sup>3)</sup>	2nd shaft end <sup>2)</sup> Holding brake Encoder <sup>3)</sup>

1) Terminal strip inside motor; sealed with a cable gland

2) Only one feature selectable; either 2nd shaft end or holding brake

3) Only in case of motor with connector version (in addition, 2nd shaft end or holding brake possible)

## 3.10 Options

### 3.10.1 Holding brake

#### ⚠ WARNING

##### LOAD FALLS DURING SWITCHING ON

When the holding brake of stepper motor drives is released and external forces are applied (vertical axes), the load may fall if the friction is low.

- In such applications, limit the load to a maximum of 25% of the static holding torque.

**Failure to follow these instructions can result in death, serious injury or equipment damage.**

*Function* The holding brake in the motor has the task of holding the current motor position when the power stage is disabled, even if external forces act (for example, in the case of a vertical axis). The holding brake is not a safety function.

For a description of the controller, see chapter 4.4.3 "Holding brake connection".

*Technical data* The signals of the holding brake meet the PELV requirements.

Holding brake for motor type BRS ●●		●● 36	●● 39	●● 3A
Nominal voltage	[V]	24± 10%	24± 10%	24± 10%
Holding torque	[Nm]	1	6	16
Electrical pull-in power	[W]	8	22	28
Moment of inertia	[kgcm <sup>2</sup> ]	0.015	0.23	0.65
Permissible energy per deceleration Q <sup>1)</sup>	[J]	6 * 10 <sup>6</sup>	8 * 10 <sup>6</sup>	13 * 10 <sup>6</sup>
Holding brake release time	[ms]	60	30	50
Holding brake application time	[ms]	14	18	20
Radial backlash	[Degrees]	0.6	0.6	0.6
Mass approx.	[kg]	0.5	1.5	3

1) The values apply to 1 ... 10 decelerations per hour.

Table 3.1 Technical data holding brake

*Holding brake controller* When the holding brake heats up to 80°C, the holding torque can decrease to 50% of the nominal torque. In the case of excessive heat, it is recommended to use a holding brake controller with voltage reduction. This allows for a voltage reduction of up to 50% after approx. 100 ms. If a holding brake controller is used, the holding brake must be connected using a shielded cable.

*Maximum braking power* The drive rating at permissible braking power is calculated with the formula:

$$Q = \frac{J * n^2}{182,4} * \frac{M_2}{M_{dec}}$$

Where:

Q = Permissible energy per deceleration [J],

J = Moment of inertia [kgcm<sup>2</sup>],

n = Speed of rotation,

M<sub>2</sub> = Nominal torque of holding brake,

M<sub>dec</sub> = Deceleration torque.

The holding brake is a product of "Chr. Mayr GmbH + Co.KG". The holding brakes of the "ROBA-Stop" and "ROBA-Stop-M" series are used. Manuals can be found on the Internet at

<http://www.mayr.com>.

*Brake application and release times* The application and release times are based on the following circuit:

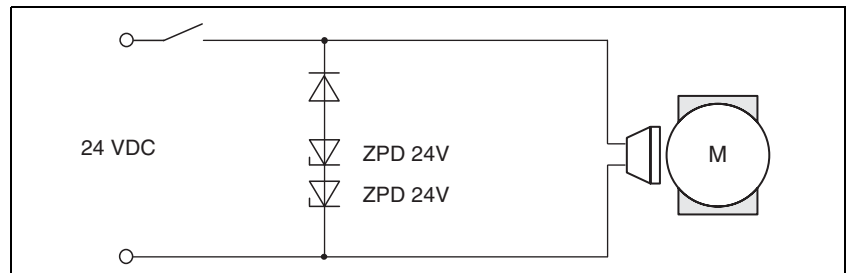

3.10.2 Encoder

3-phase stepper motors can be fitted with an optional encoder. This measuring system signals the actual position if the drive is fitted with rotation monitoring. A temperature sensor is integrated in the encoder.

The encoder signals and temperature sensor signals meet the PELV requirements.

Rotation monitoring compares the reference position and the actual position of the motor and signals an error if the difference exceeds a specific limit value. For example, this enables detection of mechanical overload of the motor.

*An encoder can only be used with motors with connector.*



Technical data

Resolution	[Pulses/min <sup>-1</sup> ]	1000
Index pulse	[Pulses/min <sup>-1</sup> ]	1
Output		RS 422
Accuracy	[°]	±1
Signals		A; B; I
Pulse shape		Rectangular
Supply voltage	[V]	5 ± 5 %
Maximum input current	[A]	0.125 (BRS36) 0.15 (BRS39 and 3A)
Temperature sensor	[°C]	100 ... 105 (BRS39 and 3A)

Signal waveform

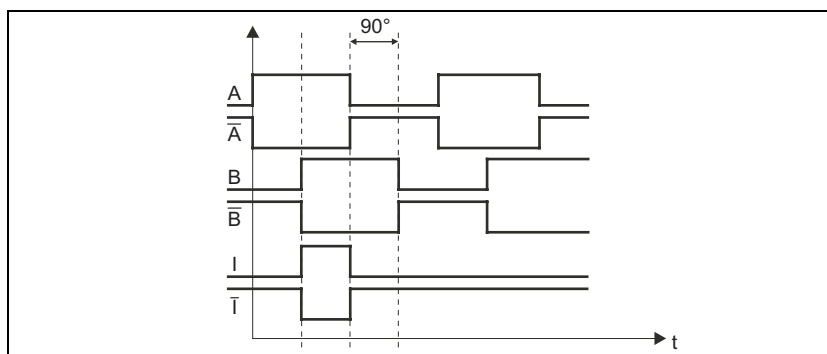

Figure 3.12 Signal waveform positive direction of rotation

Temperature monitoring

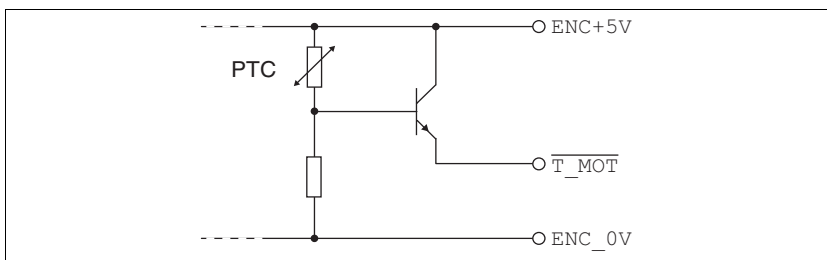

Figure 3.13 Signal for temperature monitoring



### 3.11 Conditions for UL 1004

*PELV power supply* Use only power supply units that are approved for overvoltage category III.

*Wiring* Use at least 60/75 °C copper conductors.

### 3.12 Certifications

Product certifications:

Certified by	Assigned number	Validity
UL	File E 208613	-

3.13 Declaration of conformity



SCHNEIDER ELECTRIC MOTION DEUTSCHLAND GmbH  
Breslauer Str. 7 D-77933 Lahr

**EC DECLARATION OF CONFORMITY**  
**YEAR 2011**

according to EC Directive on Machinery 2006/42/EC  
 according to EC Directive EMC 2004/108/EC  
 according to EC Directive Low Voltage 2006/95/EC

We hereby declare that the products listed below meet the requirements of the EC Directives indicated with respect to design, construction and version distributed by us. This declaration becomes invalid in the case of any modification to the products not authorized by us.

Designation:	3 Phase stepping motor
Type:	BRS3xx
Applied harmonized standards, especially:	EN 60034-1:2004 Thermal class 155 EN 60034-5:2001 Degree of protection according product documentation EN 61800-5-1:2007
Applied national standards and technical specifications, especially:	UL 1004 Product documentation

Company stamp: **Schneider Electric Motion Deutschland GmbH**  
 Postfach 11 80 • D-77901 Lahr  
 Breslauer Str. 7 • D-77933 Lahr

Date/Signature: 22 February 2011 *ppa. Hagemann*

Name/Department: Björn Hagemann/R & D

0198441113730, V2.02, 03.2011

## 4 Installation

# 4

### **▲ WARNING**

#### **UNEXPECTED BEHAVIOR CAUSED BY DAMAGE OR FOREIGN OBJECTS**

Damage to the product as well as foreign objects, deposits or humidity can cause unexpected behavior.

- Do not use damaged products.
- Keep foreign objects from getting into the product.
- Verify correct seat of seals and cable entries.

**Failure to follow these instructions can result in death, serious injury or equipment damage.**

### **▲ WARNING**

#### **STRONG ELECTROMAGNETIC FIELDS**

Motors can generate strong local electrical and magnetic fields. This can cause interference in sensitive devices.

- Keep persons with implants such as pacemakers away from the motor.
- Do not place any sensitive devices close to the motor.

**Failure to follow these instructions can result in death, serious injury or equipment damage.**

### **▲ WARNING**

#### **MOVEMENT WITHOUT BRAKING EFFECT**

If power outage or errors cause the power stage to be switched off, the motor is no longer decelerated in a controlled way and may cause damage. Overload or errors can cause hazards due to the failure of the holding brake. Incorrect use of the holding brake results in premature wear and failure.

- Secure the hazardous area so it cannot be accessed.
- Verify the function of the holding brake at regular intervals.
- Do not use the holding brake as a service brake.
- If necessary, use a cushioned mechanical stop or a suitable service brake.

**Failure to follow these instructions can result in death, serious injury or equipment damage.**

**▲ WARNING****GREAT MASS OR FALLING PARTS**

- Consider the mass of the axis when mounting the product. It may be necessary to use a crane.
- Mount the product in such a way (tightening torque, securing screws) that the axis and mounted parts cannot come loose even in the case of fast acceleration or continuous vibration.
- Note that axes subject to external forces (vertical axes) may lower unexpectedly.

**Failure to follow these instructions can result in death, serious injury or equipment damage.**

**▲ WARNING****HOT SURFACES**

The heat sink at the product may heat up to over 100°C (212°F) during operation.

- Avoid contact with the hot heat sink.
- Do not allow flammable or heat-sensitive parts in the immediate vicinity.
- Consider the measures for heat dissipation described.

**Failure to follow these instructions can result in death or serious injury.**

**▲ CAUTION****DAMAGE CAUSED BY IMPROPER APPLICATION OF FORCES**

If the motor is improperly subjected to loads, it can be damaged or fall down.

- Do not step onto the motor.
- Avoid improper use by means of safeguards at the machine or safety instructions.

**Failure to follow these instructions can result in injury or equipment damage.**

## 4.1 Before mounting

*Checking for damage* Damaged drive systems must neither be installed nor operated.

- ▶ Prior to mounting, check the drive system for visible damage.

*Checking the holding brake (option)* See chapter 8.2 "Maintenance", "Checking/running in the holding brake".

*Cleaning the shaft* The motor shafts are factory-treated with an anti-corrosive. If output components are glued to the shaft, the anti-corrosive must be removed and the shaft cleaned. If required, use a grease removal agent as specified by the glue manufacturer. If the glue manufacturer does not provide information on grease removal, it is recommended to use acetone.

- ▶ Remove the anti-corrosive. Avoid direct contact of the skin and the sealing material with the anti-corrosive or the cleaning agent.

*Mounting surface for flange* The mounting surface must be stable, clean and low-vibration.

- ▶ Verify that the system side meets all requirements in terms of dimensions and tolerances.

4.1.1 Calculation of installation space

Principle diagram

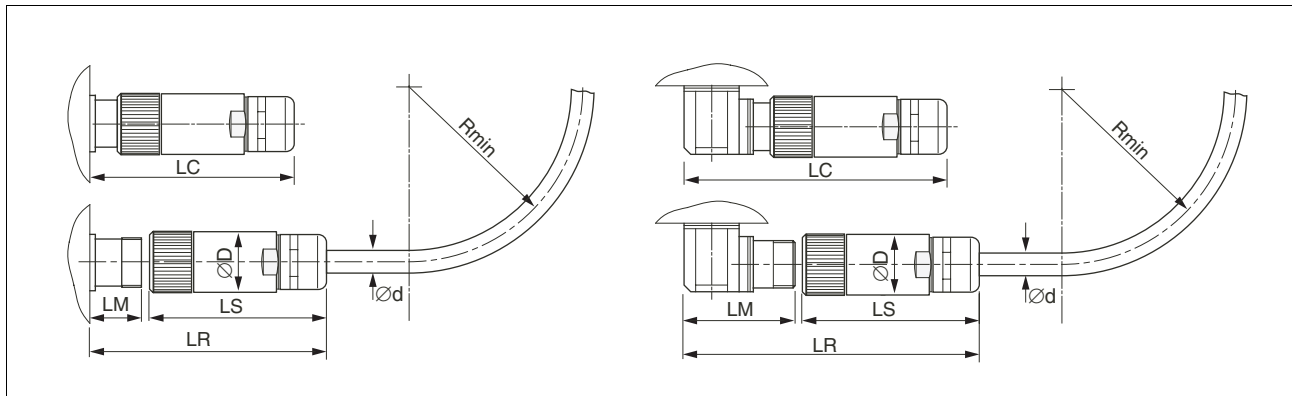

Figure 4.1 Connector installation space

Connector dimensions

Dimensions		Motor connectors	Encoder connector
D	[mm]	28	26
LS	[mm]	79	54
LR	[mm]	115	80
LC	[mm]	95	65
LM	[mm]	34	24

Cable specifications

Dimensions		Motor cable	Encoder cables
d	[mm]	10.5 (± 0.2)	8.8 (± 0.2)

Calculation

The following formula is a rule of thumb for calculating the connector installation space  $R_{min}$ :

$$R_{min} = 7.5 * d$$

In terms of the permissible temperatures, a distinction is made between stationary and moving:

- Stationary wiring: -40°C ... +85°C
- Moving wiring (drag chains): -20°C ... +85°C

## 4.2 Electromagnetic compatibility, EMC

### ⚠ WARNING

#### SIGNAL AND DEVICE INTERFERENCE

Signal interference can cause unexpected responses of device.

- Install the wiring in accordance with the EMC requirements.
- Verify compliance with the EMC requirements.

**Failure to follow these instructions can result in death, serious injury or equipment damage.**



*EMC requirement: Route motor cable separately*

*Motor and encoder cables*

*Pre-assembled motor cables and encoder cables in many different lengths are available for the drive solutions. Contact your local sales office.*

When planning the wiring, take into account the fact that the motor cable must be routed separately. The motor cable must be separate from the mains cable or the signal wires.

Motor and encoder cables are especially critical in terms of EMC. Use only pre-assembled cables or cables that comply with the specifications and implement the EMC measures described below.

EMC measures	Objective
Do not install switching elements in motor cables or encoder cables.	Reduces interference.
Route the motor cable at a distance of at least 20 cm from the signal cable or use shielding plates between the motor cable and signal cable.	Reduces mutual interference
For long lines, use equipotential bonding conductors.	Reduces current in the cable shield.
Route the motor cable and encoder cable without cutting them. <sup>1)</sup>	Reduces emission.

1) If a cable has to be cut for the installation, it has to be connected with shield connections and a metal housing at the point of the cut.

*Pre-assembled connection cables (accessories)*

Use pre-assembled cables to reduce the risk of wiring errors, see chapter 7 "Accessories and spare parts".

Place the female connector of the motor cable onto the male connector and tighten the union nut. Proceed in the same manner with the connection cable of the encoder system. Connect the motor cable and the encoder cable to the drive according to the wiring diagram of the drive.

### 4.3 Mechanical installation

#### **⚠ WARNING**

##### **UNEXPECTED MOVEMENT CAUSED BY ELECTROSTATIC DISCHARGE**

In rare cases, electrostatic discharge to the shaft may cause incorrect operation of the encoder system and result in unexpected motor movements and damage to the bearing.

- Use conductive components (such as antistatic belts) or other suitable measures to avoid static charge by motion.

**Failure to follow these instructions can result in death, serious injury or equipment damage.**

#### **⚠ WARNING**

##### **UNEXPECTED MOVEMENT**

If the approved ambient conditions are exceeded, external substances from the environment may penetrate and cause unexpected movement or equipment damage.

- Verify that the ambient conditions are met.
- Do not allow seals to run dry.
- Keep liquids from getting to the shaft bushing (for example in mounting position IM V3).
- Do not expose the shaft sealing rings and cable entries to the direct spray of a pressure washer.

**Failure to follow these instructions can result in death, serious injury or equipment damage.**

#### **⚠ WARNING**

##### **UNINTENDED BEHAVIOR CAUSED BY MECHANICAL DAMAGE TO THE MOTOR**

If the maximum permissible forces at the shaft are exceeded, this will result in premature wear of the bearing, shaft breakage or damage to the encoder.

- Do not exceed the maximum permissible axial and radial forces.
- Protect the shaft from impact.
- Do not exceed the maximum permissible axial force when pressing on components.

**Failure to follow these instructions can result in death, serious injury or equipment damage.**

#### *Mounting position*

The following mounting positions are defined and approved as per IEC 60034-7:

- IM B5 drive shaft horizontal
- IM V1 drive shaft vertical, shaft end down
- IM V3 drive shaft vertical, shaft end up



*Mounting* When the motor is mounted to the mounting flange, it must be accurately aligned and have full-surface contact. There must be no tension. The mounting flange as well as the parts mounted to the shaft must be rated for the dynamic loads that may result during operation.

*Mounting output components* If output components are not properly mounted, the encoder may be damaged. Output components such as pulleys, couplings must be mounted with suitable equipment and tools. The maximum axial and radial forces acting on the shaft must not exceed the maximum shaft load values specified, see 3.8.2 "Shaft load".

Observe the mounting instructions provided by the manufacturer of the output component. Motor and output component must be accurately aligned both axially and radially. Failure to follow the instructions will cause runout, damage to the rolling bearings and premature wear.

## 4.4 Electrical installation

The motors are not designed for direct connection to mains power; they may only be operated with a suitable power stage.

### **⚠ DANGER**

#### **ELECTRIC SHOCK AND FIRE CAUSED BY INCORRECT INSTALLATION OF THE CABLE**

Incorrect installation of the cable may destroy the insulation. Broken conductors in the cable or improperly connected connectors may be melted by arcs.

- Avoid impermissible movements of the cable.
- Avoid forces or movements of the cable at the cable entry.
- Verify that the connector is properly plugged in and locked.

**Failure to follow these instructions will result in death or serious injury.**

### **⚠ WARNING**

#### **UNEXPECTED BEHAVIOR CAUSED BY FOREIGN OBJECTS**

Foreign objects, deposits or humidity can cause unexpected behavior.

- Keep foreign objects from getting into the product.
- Do not use damaged products.
- Do not remove the cover of the electronics housing. Only remove the connector housing cover.
- Verify correct seat of seals and cable entries.

**Failure to follow these instructions can result in death, serious injury or equipment damage.**

#### *Equipotential bonding conductors*

Potential differences can result in excessive currents on the cable shields. Use equipotential bonding conductors to reduce currents on the cable shields.

The equipotential bonding conductor must be rated for the maximum current flowing. Practical experience has shown that the following conductor cross sections can be used:

- 16 mm<sup>2</sup> (AWG 4) for equipotential bonding conductors up to a length of 200 m
- 20 mm<sup>2</sup> (AWG 4) for equipotential bonding conductors with a length of more than 200 m

*Protective ground conductor  
connection*

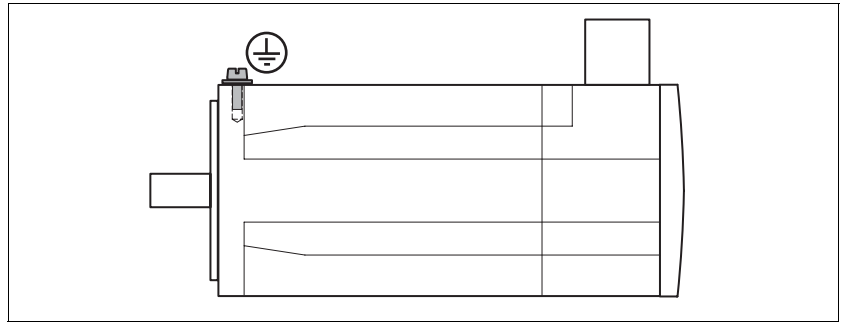

- ▶ Ground the motor via the grounding screw if grounding via the flange and the protective ground conductor of the motor cable is not sufficient.

### 4.4.1 Motor connection

- Protective ground conductor and shield must be connected to the motor and the device.
- Insulate both ends of unused conductors of the cable.
- The terminal box does not have to be opened for connection of the motor by means of a connector. For connection in the terminal box, only unscrew the four screws of the terminal box. See Figure 4.2.
- Two motor phases (for example, U and V) can be interchanged to change the direction of rotation of the motor shaft.

The motor phases of motors with encoder must not be interchanged.

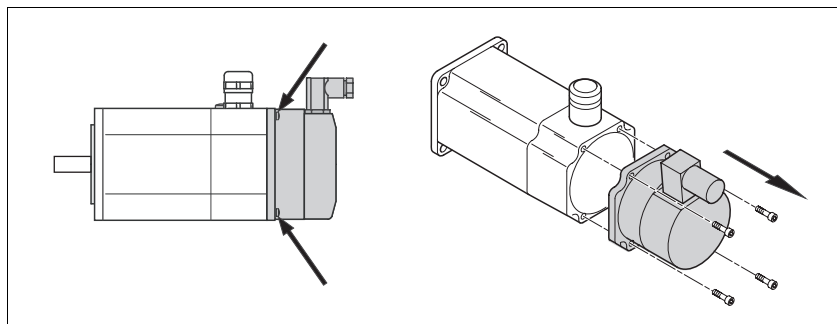

Figure 4.2 Opening the terminal box

#### *Cable specifications*

Use pre-assembled cables to reduce the risk of wiring errors. See chapter 7 "Accessories and spare parts".

Cable specifications		
Shielded cable		Required, both shield ends grounded
Conductor cross section	[mm <sup>2</sup> ]	4*1.5 (AWG 14)
Rated voltage	[V]	800

Table 4.1 Cable specifications for motor cables

Wiring diagram motor with terminal box (symbolic)

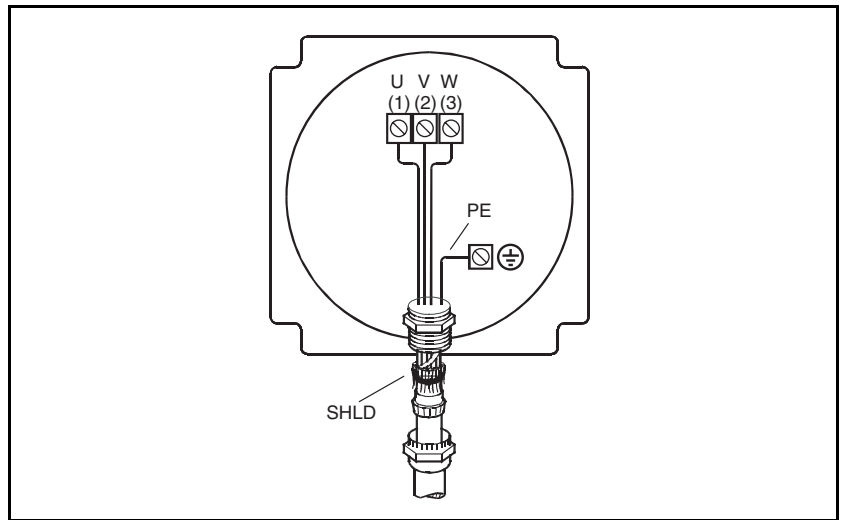

Figure 4.3 Wiring diagram motor with terminal box (symbolic)

Pin	Connection	Meaning	Wire color (IEC 757)
1	U	Motor phase	Brown (BN)
2	V	Motor phase	Blue (BU)
3	W	Motor phase	Black (BK)
	PE	Protective ground conductor	Green/yellow (GN/YE)
	SHLD	Shield	

Tightening torque of motor terminals	[Nm] (lb-in)	0.6 (5.31)
Tightening torque of housing screws	[Nm] (lb-in)	0.6 (5.31)

Wiring diagram for motor with connector

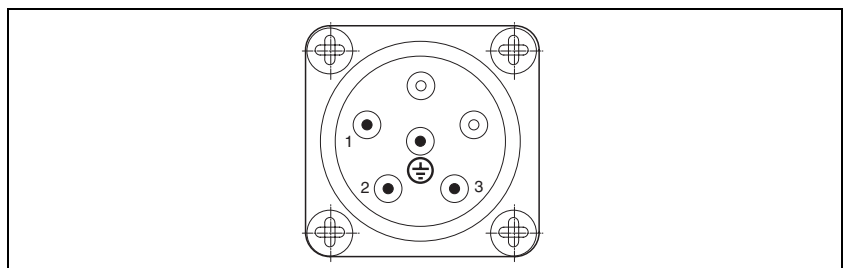

Figure 4.4 Connector, view of motor side to the contact pins

Pin	Connection	Meaning
1	U	Motor phase
2	V	Motor phase
3	W	Motor phase
4	PE	Protective ground conductor

## 4.4.2 Encoder connection



The shield must be connected to the motor and the device.

Insulate both ends of unused conductors of the cable.

*Cable specifications*

Use pre-assembled cables to reduce the risk of wiring errors. See chapter 7 "Accessories and spare parts".

Shielded encoder cable with 5 x (2\*0.25 mm<sup>2</sup>) and 1 x (2\*0.5 mm<sup>2</sup>) twisted pair wires.

*Wiring diagram encoder*

Figure 4.5 Wiring diagram encoder

Pin	Designation	Meaning
1	ENC_A	Encoder signal channel A
2	$\overline{\text{ENC\_A}}$	Encoder signal channel A, inverted
3	ENC_B	Encoder signal channel B
4	$\overline{\text{ENC\_B}}$	Encoder signal channel B, inverted
5	ENC_I	Encoder signal channel I
6	$\overline{\text{ENC\_I}}$	Encoder signal channel I, inverted
7	ENC_0V	Reference potential to ENC+5V
8	ENC+5V	5V <sub>dc</sub> power supply for encoder
9	ENC_0V_SENSE	Reference potential to ENC+5V_SENSE
10	ENC+5V_SENSE	SENSE line to ENC+5V
11	$\overline{\text{T\_MOT}}$	Temperature sensor
12		Not assigned

4.4.3 Holding brake connection

**⚠ WARNING**

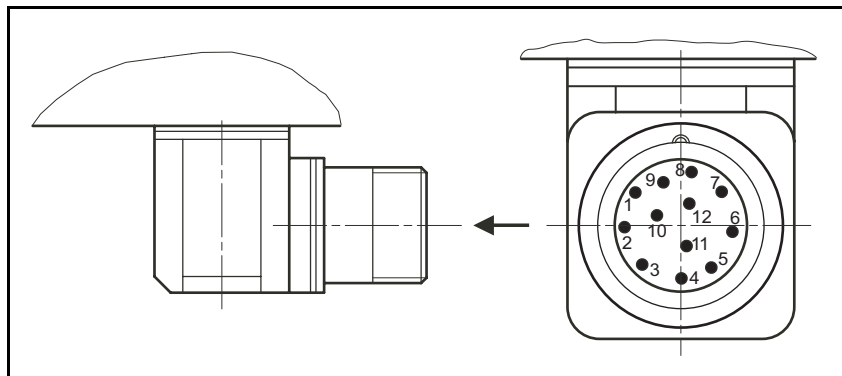
**LOSS OF BRAKING FORCE DUE TO WEAR OR HIGH TEMPERATURE**

Applying the holding brake while the motor is running will cause excessive wear and loss of the braking force. Heat decreases the braking force.

- Do not use the holding brake as a service brake.
- Note that "EMERGENCY STOPS" may also cause wear
- At operating temperatures of more than 80°C (176°F), do not exceed a maximum of 50% of the specified holding torque when using the brake.

**Failure to follow these instructions can result in death, serious injury or equipment damage.**

**⚠ WARNING**

**LOAD FALLS DURING SWITCHING ON**

When the holding brake of stepper motor drives is released and external forces are applied (vertical axes), the load may fall if the friction is low.

- In such applications, limit the load to a maximum of 25% of the static holding torque.

**Failure to follow these instructions can result in death, serious injury or equipment damage.**

*Controlling the holding brake*

A motor with a holding brake requires a holding brake controller which releases the holding brake when a movement is to be started and applies the holding brake after a motor stop. The holding brake must be applied in the case of a voltage drop or when the power stage is disabled.

*Wiring diagram of holding brake*

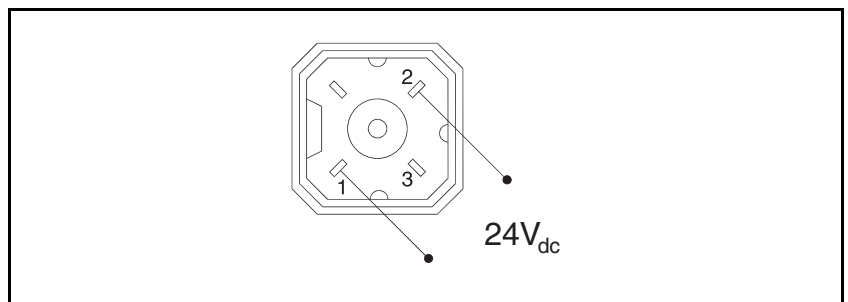

Figure 4.6 Wiring diagram of holding brake

Pin	Signal	Meaning	I/O
1, 2	24V <sub>dc</sub>	Power supply of holding brake (non-polarized)	I

The connector is a part of the scope of supply.  
Connector designation: Hirschmann type G4 A 5M





## 5 Commissioning

# 5

### **▲ WARNING**

#### **UNEXPECTED MOVEMENT**

Drives may perform unexpected movements because of incorrect connection or other errors.

- Operate the motor with suitable power stages only.
- Verify proper wiring. Even if the connectors for motor connection and encoder system of a third-party power stage vendor match, this does not indicate compatibility.
- Only start the system if there are no persons or obstructions in the hazardous area.
- Perform the first test runs without coupled loads.
- Do not touch the motor shaft or the mounted output components.

**Failure to follow these instructions can result in death, serious injury or equipment damage.**

### **▲ WARNING**

#### **ROTATING PARTS**

Rotating parts may cause injuries and may catch clothing or hair. Loose parts or parts that are out of balance may be catapulted away.

- Verify correct mounting and installation of all rotating parts.
- Use a cover to help protect against rotating parts.

**Failure to follow these instructions can result in death, serious injury or equipment damage.**

### **▲ WARNING**

#### **FALLING PARTS**

The motor may move, tip and crash down as a result of the reaction torque.

- Mount the motor securely so it will not break loose during strong acceleration.

**Failure to follow these instructions can result in death, serious injury or equipment damage.**

**▲ WARNING****HOT SURFACES**

The heat sink at the product may heat up to over 100°C (212°F) during operation.

- Avoid contact with the hot heat sink.
- Do not allow flammable or heat-sensitive parts in the immediate vicinity.
- Consider the measures for heat dissipation described.

**Failure to follow these instructions can result in death or serious injury.**

## 5.1 Preparing for commissioning

Commissioning procedure:

- ▶ Check the mechanical installation.
- ▶ Check the electrical installation.

In particular, verify proper connection of the protective ground conductors. Check wiring and connection of all cables and system components. Verify that all cable glands are properly tightened.

- ▶ Check the ambient conditions.

Verify that the ambient conditions specified are met.

- ▶ Check the output components.

Verify that any output components installed are balanced and accurately aligned.

- ▶ Check the parallel key at the shaft end of the motor.

If you have a motor with a parallel key groove and parallel key, the parallel key must not be inserted during commissioning without output component or it must be appropriately secured.

- ▶ Verify the function of the holding brake.

Verify that the holding brake can hold the maximum acting load.

Verify that the holding brake is released before a movement is started.



*Observe the information on commissioning in the product manual of the drive.*

## 6 Diagnostics and troubleshooting

# 6

### 6.1 Mechanical problems

Error	Cause	Troubleshooting
Excessive heat	Overload Holding brake not released Heavy pollution	Reduce load Check the holding brake controller Clean the motor
Whistling or knocking noise	Rolling bearings	Contact service
Grinding noise	Rotating output component grinds	Align output component
Radial oscillation	Poor alignment of output component Output element out of balance Shaft bent Resonance with mounting elements	Align output component Balance output component Contact service Check the stiffness of the motor mounting
Excessive heat	Overload Holding brake not released Heavy pollution	Reduce load Check the holding brake controller Clean the motor
Encoder does not operate or only operates sporadically	Encoder damaged due to axial movement of the motor shaft (maximum axial load exceeded)	Verify that the permissible axial force is not exceeded.

### 6.2 Electrical problems

Error	Cause	Troubleshooting
Motor does not start or starts with problems	Overload Unsuitable settings for the drive Cable damaged	Reduce load Check drive settings Check cables and connections
Excessive heat	Overload	Reduce power
Heat at the connection terminals	Connector loose or not tightened	Tighten connector



## 7 Accessories and spare parts

# 7

### 7.1 Accessories

Description	Order no.
Holding brake controller HBC	VW3M3103

### 7.2 Motor cables

Description	Order no.
Motor cable for stepper motor 4 x 1.5 shielded, motor end with 6-pin circular connector; other cable end open; length 3 m	VW3S5101R30
Motor cable for stepper motor 4 x 1.5 shielded, motor end with 6-pin circular connector; other cable end open; length 5 m	VW3S5101R50
Motor cable for stepper motor 4 x 1.5 shielded, motor end with 6-pin circular connector; other cable end open; length 10 m	VW3S5101R100
Motor cable for stepper motor 4 x 1.5 shielded, motor end with 6-pin circular connector; other cable end open; length 15 m	VW3S5101R150
Motor cable for stepper motor 4 x 1.5 shielded, motor end with 6-pin circular connector; other cable end open; length 20 m	VW3S5101R200
Motor cable for stepper motor 4 x 1.5 shielded, both cable ends open; length 3 m	VW3S5102R30
Motor cable for stepper motor 4 x 1.5 shielded, both cable ends open; length 5 m	VW3S5102R50
Motor cable for stepper motor 4 x 1.5 shielded, both cable ends open; length 10 m	VW3S5102R100
Motor cable for stepper motor 4 x 1.5 shielded, both cable ends open; length 15 m	VW3S5102R150
Motor cable for stepper motor 4 x 1.5 shielded, both cable ends open; length 20 m	VW3S5102R200

### 7.3 Encoder cables

Description	Order no.
Encoder cable for stepper motor; shielded; motor end with 12-pin circular connector; other cable end 12-pin Molex connector; length 3 m	VW3S8101R30
Encoder cable for stepper motor; shielded; motor end with 12-pin circular connector; other cable end 12-pin Molex connector; length 5 m	VW3S8101R50
Encoder cable for stepper motor; shielded; motor end with 12-pin circular connector; other cable end 12-pin Molex connector; length 10 m	VW3S8101R100
Encoder cable for stepper motor; shielded; motor end with 12-pin circular connector; other cable end 12-pin Molex connector; length 15 m	VW3S8101R150
Encoder cable for stepper motor; shielded; motor end with 12-pin circular connector; other cable end 12-pin Molex connector; length 20 m	VW3S8101R200
Connector kit, Molex connector 12-pin, with crimp contacts, 5 connectors	VW3M8213



## 8 Service, maintenance and disposal

# 8



*The product may only be repaired by a Schneider Electric customer service center. No warranty or liability is accepted for repairs made by unauthorized persons.*

### 8.1 Service address

If you cannot resolve an error yourself please contact your sales office. Have the following details available:

- Nameplate (type, identification number, serial number, DOM, ...)
- Type of error (with LED flash code or error number)
- Previous and concomitant circumstances
- Your own assumptions concerning the cause of the error

Also include this information if you return the product for inspection or repair.



*If you have any questions please contact your sales office. Your sales office staff will be happy to give you the name of a customer service office in your area.*

<http://www.schneider-electric.com>

### 8.2 Maintenance

Repairs may only be made by the manufacturer. No warranty or liability is accepted for repairs made by unauthorized persons.

Repairs cannot be made with the device installed.



*Prior to any type of work on the drive system, consult the chapters on Installation and Commissioning for information on the precautions and processes to be observed.*

Include the following points in the maintenance plan of your machine.

#### *Connections and fastening*

- ▶ Check all connection cables and connectors regularly for damage. Replace damaged cables immediately.
- ▶ Check that all output elements are firmly seated.
- ▶ Tighten all mechanical and electrical threaded connections to the specified torque. Check the union nuts at the connection cables.

#### *Lubricating the shaft sealing ring*

In the case of motors with shaft sealing ring, lubricant must be applied to the space between the sealing lip of the shaft sealing ring and the shaft with a suitable non-metallic tool. If the shaft sealing rings are allowed to run dry, the service life of the shaft sealing rings will be significantly reduced.

## Cleaning

**▲ WARNING****UNEXPECTED MOVEMENT**

If the approved ambient conditions are exceeded, external substances from the environment may penetrate and cause unexpected movement or equipment damage.

- Verify that the ambient conditions are met.
- Do not allow seals to run dry.
- Keep liquids from getting to the shaft bushing (for example in mounting position IM V3).
- Do not expose the shaft sealing rings and cable entries to the direct spray of a pressure washer.

**Failure to follow these instructions can result in death, serious injury or equipment damage.**

Clean dust and dirt off the motor at regular intervals. Insufficient heat dissipation to the ambient air may excessively increase the temperature.

Motors are not suitable for cleaning with a pressure washer. The high pressure may force water into the motor.

When using solvents or cleaning agents, verify that the motor and encoder cables, cable entry seals, O rings and motor paint are not damaged.

## Checking/running in the holding brake



*Occasional braking while the load moves helps to maintain the holding torque of the holding brake. If the brake does not work mechanically for an extended period of time, parts of the holding brake may corrode. Corrosion reduces the holding torque.*

The holding brake is factory run in. If the brake does not work mechanically for an extended period of time, parts of the holding brake may corrode. If the holding brake does not have the holding torque indicated in the technical data, it must be run in again.

- The motor is dismounted. The holding brake is applied.
- ▶ Check the holding torque of the holding brake using a torque wrench.
- ▶ Compare the value to the specified holding torque of the holding brake when it was delivered. See Table 3.1 "Technical data holding brake" in chapter 3.10.1 "Holding brake"
- ▶ If the holding torque of the holding brake considerably differs from the specified values, manually rotate the motor shaft by 25 rotations in both directions.
- ▶ Repeat the process. Contact your sales office if you cannot restore the original holding torque by repeating the process 3 times.

## Replacing the rolling bearing

The customer must not replace the rolling bearing. The motor will be partially demagnetized by this procedure and lose power.



### 8.3 Changing the motor

- ▶ Switch off all supply voltages. Verify that no voltages are present (safety instructions).
- ▶ Label all connections and uninstall the product.
- ▶ Note the identification number and the serial number shown on the product nameplate for later identification.
- ▶ Install the new product as per chapter 4 "Installation".
- ▶ Commission the product as per chapter 5 "Commissioning".

### 8.4 Shipping, storage, disposal

Note the ambient conditions in chapter 3.2 "Ambient conditions".

- Shipping* The product must be protected against shocks during transportation. If possible, use the original packaging for shipping.
- Storage* The product may only be stored in spaces where the specified permissible ambient conditions are met.  
Protect the product from dust and dirt.
- Disposal* The product consists of various materials that can be recycled. Dispose of the product in accordance with local regulations.



## 9 Glossary

# 9

### 9.1 Units and conversion tables

The value in the specified unit (left column) is calculated for the desired unit (top row) with the formula (in the field).

Example: conversion of 5 meters [m] to yards [yd]  
 $5 \text{ m} / 0.9144 = 5.468 \text{ yd}$

#### 9.1.1 Length

	in	ft	yd	m	cm	mm
in	-	/ 12	/ 36	* 0.0254	* 2.54	* 25.4
ft	* 12	-	/ 3	* 0.30479	* 30.479	* 304.79
yd	* 36	* 3	-	* 0.9144	* 91.44	* 914.4
m	/ 0.0254	/ 0.30479	/ 0.9144	-	* 100	* 1000
cm	/ 2.54	/ 30.479	/ 91.44	/ 100	-	* 10
mm	/ 25.4	/ 304.79	/ 914.4	/ 1000	/ 10	-

#### 9.1.2 Mass

	lb	oz	slug	kg	g
lb	-	* 16	* 0.03108095	* 0.4535924	* 453.5924
oz	/ 16	-	* $1.942559 \cdot 10^{-3}$	* 0.02834952	* 28.34952
slug	/ 0.03108095	/ $1.942559 \cdot 10^{-3}$	-	* 14.5939	* 14593.9
kg	/ 0.45359237	/ 0.02834952	/ 14.5939	-	* 1000
g	/ 453.59237	/ 28.34952	/ 14593.9	/ 1000	-

#### 9.1.3 Force

	lb	oz	p	dyne	N
lb	-	* 16	* 453.55358	* 444822.2	* 4.448222
oz	/ 16	-	* 28.349524	* 27801	* 0.27801
p	/ 453.55358	/ 28.349524	-	* 980.7	* $9.807 \cdot 10^{-3}$
dyne	/ 444822.2	/ 27801	/ 980.7	-	/ $100 \cdot 10^3$
N	/ 4.448222	/ 0.27801	/ $9.807 \cdot 10^{-3}$	* $100 \cdot 10^3$	-

#### 9.1.4 Power

	HP	W
HP	-	* 746
W	/ 746	-

## 9.1.5 Rotation

	min <sup>-1</sup> (RPM)	rad/s	deg./s
min <sup>-1</sup> (RPM)	-	* $\pi / 30$	* 6
rad/s	* $30 / \pi$	-	* 57.295
deg./s	/ 6	/ 57.295	-

## 9.1.6 Torque

	lb-in	lb-ft	oz-in	Nm	kp-m	kp-cm	dyne-cm
lb-in	-	/ 12	* 16	* 0.112985	* 0.011521	* 1.1521	* $1.129 \times 10^6$
lb-ft	* 12	-	* 192	* 1.355822	* 0.138255	* 13.8255	* $13.558 \times 10^6$
oz-in	/ 16	/ 192	-	* $7.0616 \times 10^{-3}$	* $720.07 \times 10^{-6}$	* $72.007 \times 10^{-3}$	* 70615.5
Nm	/ 0.112985	/ 1.355822	/ $7.0616 \times 10^{-3}$	-	* 0.101972	* 10.1972	* $10 \times 10^6$
kp-m	/ 0.011521	/ 0.138255	/ $720.07 \times 10^{-6}$	/ 0.101972	-	* 100	* $98.066 \times 10^6$
kp-cm	/ 1.1521	/ 13.8255	/ $72.007 \times 10^{-3}$	/ 10.1972	/ 100	-	* $0.9806 \times 10^6$
dyne-cm	/ $1.129 \times 10^6$	/ $13.558 \times 10^6$	/ 70615.5	/ $10 \times 10^6$	/ $98.066 \times 10^6$	/ $0.9806 \times 10^6$	-

## 9.1.7 Moment of inertia

	lb-in <sup>2</sup>	lb-ft <sup>2</sup>	kg-m <sup>2</sup>	kg-cm <sup>2</sup>	kp-cm-s <sup>2</sup>	oz-in <sup>2</sup>
lb-in <sup>2</sup>	-	/ 144	/ 3417.16	/ 0.341716	/ 335.109	* 16
lb-ft <sup>2</sup>	* 144	-	* 0.04214	* 421.4	* 0.429711	* 2304
kg-m <sup>2</sup>	* 3417.16	/ 0.04214	-	* $10 \times 10^3$	* 10.1972	* 54674
kg-cm <sup>2</sup>	* 0.341716	/ 421.4	/ $10 \times 10^3$	-	/ 980.665	* 5.46
kp-cm-s <sup>2</sup>	* 335.109	/ 0.429711	/ 10.1972	* 980.665	-	* 5361.74
oz-in <sup>2</sup>	/ 16	/ 2304	/ 54674	/ 5.46	/ 5361.74	-

## 9.1.8 Temperature

	°F	°C	K
°F	-	(°F - 32) * 5/9	(°F - 32) * 5/9 + 273.15
°C	°C * 9/5 + 32	-	°C + 273.15
K	(K - 273.15) * 9/5 + 32	K - 273.15	-

## 9.1.9 Conductor cross section

AWG	1	2	3	4	5	6	7	8	9	10	11	12	13
mm <sup>2</sup>	42.4	33.6	26.7	21.2	16.8	13.3	10.5	8.4	6.6	5.3	4.2	3.3	2.6

AWG	14	15	16	17	18	19	20	21	22	23	24	25	26
mm <sup>2</sup>	2.1	1.7	1.3	1.0	0.82	0.65	0.52	0.41	0.33	0.26	0.20	0.16	0.13

## 9.2 Terms and Abbreviations

See chapter 2.5 "Standards and terminology" for information on the pertinent standards on which many terms are based. Some terms and abbreviations may have specific meanings with regard to the standards.

<i>Axial forces</i>	Tension or compression forces acting longitudinally on the shaft
<i>Centering collar</i>	Centering device at the motor flange that allows for accurate motor mounting.
<i>DOM</i>	<b>Date of manufacturing:</b> The nameplate of the product shows the date of manufacture in the format DD.MM.YY or in the format DD.MM.YYYY. Example: 31.12.09 corresponds to December 31, 2009 31.12.2009 corresponds to December 31, 2009
<i>Degree of protection</i>	The degree of protection is a standardized specification for electrical equipment that describes the protection against the ingress of foreign objects and water (for example: IP 20).
<i>EMC</i>	Electromagnetic compatibility
<i>Encoder</i>	Sensor for detection of the angular position of a rotating component. Installed in a motor, the encoder shows the angular position of the rotor.
<i>Error</i>	Discrepancy between a detected (computed, measured or signaled) value or condition and the specified or theoretically correct value or condition.
<i>Error class</i>	Classification of errors into groups. The different error classes allow for specific responses to errors, for example by severity.
<i>Fatal error</i>	In the case of fatal error, the product is no longer able to control the motor so that the power stage must be immediately disabled.
<i>Fault</i>	Fault is a state that can be caused by an error. Further information can be found in the pertinent standards such as IEC 61800-7, ODVA Common Industrial Protocol (CIP).
<i>Fault reset</i>	A function used to restore the drive to an operational state after a detected error is cleared by removing the cause of the error so that the error is no longer active.
<i>Holding brake</i>	The holding brake in the motor has the task of holding the current motor position when the power stage is disabled, even if external forces act (for example, in the case of a vertical axis). The holding brake is not a safety function.
<i>Length</i>	In the type code, the length is defined in terms of the number of stacks.
<i>PTC</i>	Resistor with positive temperature coefficient. Resistance value increases as the temperature rises.
<i>Radial forces</i>	Forces that act radially on the shaft
<i>Shaft sealing ring</i>	A sealing ring with a fixed seat in the motor flange. The sealing lip runs on the surface of the rotating shaft, which increases the degree of protection of the shaft bushing. Regular lubrication of the shaft sealing ring is essential and the allowable maximum speed of the motor shaft must not be exceeded.
<i>Size</i>	In the type code, the size is defined in terms of the flange size.

*Warning* If the term is used outside the context of safety instructions, a warning alerts to a potential problem that was detected by a monitoring function. A warning does not cause a transition of the operating state.

---

**10 Index****10****A**

- Abbreviations 77
- Accessories 69
- Accessories and spare parts 69

**B**

- Before you begin
  - Safety information 15

**C**

- Certifications 49
- Changing the motor 73
- Characteristic curves 28
  - BRS364 28
  - BRS366 29
  - BRS368 30
  - BRS397 31
  - BRS39A 32
  - BRS39B 33
  - BRS3AC 34
  - BRS3AD 35
- Commissioning 65
  - preparation 66
- Connector installation space 54

**D**

- Diagnostics 67
- Dimensional drawing
  - BRS36 36
  - BRS39 38
  - BRS3A 40
- dimensional drawing, see dimensions
- Dimensions 36
- Disposal 71, 73

**E**

- EMC 55
  - Motor cable and encoder cable 55
- EMC requirement
  - Route motor cable separately 55
- Encoder 48
  - Technical data 46, 48
  - Temperature monitoring 48
  - Wiring diagram 62
- Encoder cable
  - EMC requirements 55
- Environmental conditions

Operation 22  
Environmental conditions transportation and storage 22  
Equipotential bonding conductors 58

## F

Force for pressing on 42

## G

General features 21  
Glossary 75

## H

Hazard categories 16  
Holding brake 46  
    Wiring diagram 63  
Holding brake controller 46

## I

Installation  
    mechanical 56  
Intended use 15  
Introduction 9  
IP degree of protection 24

## M

Maintenance 71  
Manuals  
    Source 7  
Maximum press-on force 42  
Mechanical installation 56  
Motor cable  
    EMC requirements 55  
Motor versions 45  
Motor with connector  
    wiring diagram 61  
Motor with terminal box  
    Wiring diagram 61  
Motor-specific data 25  
    BRS36x 25  
    BRS39x 26  
    BRS3Ax 26  
Mounting 57  
Mounting position 56

## N

Name plate 11

## O

Options 46

## P

PELV power supply UL 49  
Press-on force 42



**Q**

Qualification of personnel 15

**S**

Service 71

Service address 71

Service life 23

Shaft load

BRS36x 43

BRS39x 43

BRS3Ax 44

Shaft sealing ring 24

Shaft-specific data 42

Shipping 73

Signal waveform encoder 48

Source

Manuals 7

Storage 73

**T**

Technical data 21

Encoder 46, 48

Temperature monitoring (encoder) 48

Terms 77

Troubleshooting 67

Type code

BRS36 12

BRS39 overview 13

BRS3A overview 14

**U**

UL, conditions for

PELV power supply 49

Wiring 49

Units and conversion tables 75

**V**

Voltage reduction 46

**W**

Wiring diagram

Encoder 62

Holding brake 63

motor with connector 61

Motor with terminal box 61

Wiring UL 49

