

# NetBotz Room Monitor 755

## Installation and Quick Start

NBWL0755

990-6171A-001

Release date: 11/2019

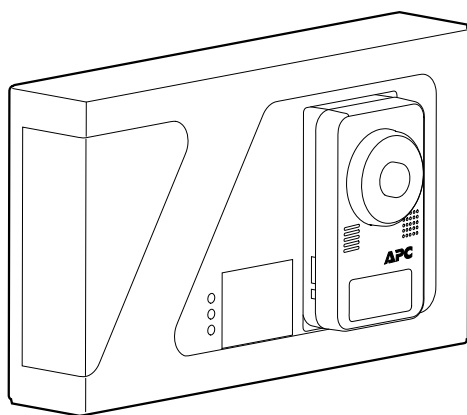

# Legal Information

The Schneider Electric brand and any trademarks of Schneider Electric SE and its subsidiaries referred to in this guide are the property of Schneider Electric SE or its subsidiaries. All other brands may be trademarks of their respective owners.

This guide and its content are protected under applicable copyright laws and furnished for informational use only. No part of this guide may be reproduced or transmitted in any form or by any means (electronic, mechanical, photocopying, recording, or otherwise), for any purpose, without the prior written permission of Schneider Electric.

Schneider Electric does not grant any right or license for commercial use of the guide or its content, except for a non-exclusive and personal license to consult it on an "as is" basis. Schneider Electric products and equipment should be installed, operated, serviced, and maintained only by qualified personnel.

As standards, specifications, and designs change from time to time, information contained in this guide may be subject to change without notice.

To the extent permitted by applicable law, no responsibility or liability is assumed by Schneider Electric and its subsidiaries for any errors or omissions in the informational content of this material or consequences arising out of or resulting from the use of the information contained herein.

APC, the APC Logo, and NetBotz are trademarks of Schneider Electric SE. All other brands may be trademarks of their respective owners.

---

# Table of Contents

Important Safety Instructions — SAVE THESE INSTRUCTIONS .....	5
Safety Information for the Room Monitor 755.....	6
General Information .....	7
Additional Options .....	8
Updates and Related Documents .....	8
Inventory .....	9
Physical Description .....	11
Status LED .....	12
Link (10/100/1000) LED .....	12
Care and Disposal.....	12
Installation .....	13
Wall Mount .....	14
Rack Mount .....	14
Power and Network Connections.....	15
Connect Sensors and Devices .....	16
Cascade Sensors and Pods from A-Link Ports .....	17
The Wireless Sensor Network .....	18
Devices on the Wireless Sensor Network .....	18
Connect the Wireless Sensor Network .....	19
Initial Configuration .....	20
Establish Network Settings .....	20
Use Your Computer to Establish Network Settings .....	20
Use a Terminal Emulator to Establish Network Settings .....	22
Access the Appliance .....	23
Access the Web User Interface (Web UI).....	23
REST API .....	24
Types of User Accounts .....	24
Reset a Lost Super User Password.....	24
Reset a Lost Root Account Password .....	25
Reset to Defaults.....	25
Add Sensors to the Wireless Sensor Network.....	26
Connect Downstream Devices .....	27
Control Devices by Outlet .....	28
Configure Alarms .....	28
Update the Firmware.....	29
Specifications.....	30
Two-year Factory Warranty.....	32
Terms of Warranty.....	32
Non-transferable Warranty.....	32
Exclusions.....	32
Warranty Claims .....	33
Radio Frequency Interference.....	34



# Important Safety Instructions — SAVE THESE INSTRUCTIONS

Read these instructions carefully and look at the equipment to become familiar with it before trying to install, operate, service or maintain it. The following safety messages may appear throughout this manual or on the equipment to warn of potential hazards or to call attention to information that clarifies or simplifies a procedure.



The addition of this symbol to a “Danger” or “Warning” safety message indicates that an electrical hazard exists which will result in personal injury if the instructions are not followed.



This is the safety alert symbol. It is used to alert you to potential personal injury hazards. Obey all safety messages with this symbol to avoid possible injury or death.

## **DANGER**

**DANGER** indicates a hazardous situation which, if not avoided, **will result in** death or serious injury.

**Failure to follow these instructions will result in death or serious injury.**

## **WARNING**

**WARNING** indicates a hazardous situation which, if not avoided, **could result in** death or serious injury.

**Failure to follow these instructions can result in death, serious injury, or equipment damage.**

## **CAUTION**

**CAUTION** indicates a hazardous situation which, if not avoided, **could result in** minor or moderate injury.

**Failure to follow these instructions can result in injury or equipment damage.**

## **NOTICE**

**NOTICE** is used to address practices not related to physical injury. The safety alert symbol shall not be used with this type of safety message.

**Failure to follow these instructions can result in equipment damage.**

## Please Note

Electrical equipment should only be installed, operated, serviced, and maintained by qualified personnel. No responsibility is assumed by APC by Schneider Electric for any consequences arising out of the use of this material.

A qualified person is one who has skills and knowledge related to the construction, installation, and operation of electrical equipment and has received safety training to recognize and avoid the hazards involved.

## Safety Information for the Room Monitor 755

### **DANGER**

#### **HAZARD OF SHOCK, EXPLOSION, OR ARC FLASH**

- The device must be installed and operated by a skilled person in a controlled location.
- All electrical work must be performed by qualified personnel.
- Turn off all power supplying the equipment before working on the equipment.
- Practice Lockout/Tagout procedures.
- Do not wear jewelry when working on electrical equipment.

**Failure to follow these instructions will result in death or serious injury.**

### **CAUTION**

#### **FALLING EQUIPMENT HAZARD**

Do not create a hazardous condition due to uneven mechanical loading. For example, do not use the unit as a shelf.

**Failure to follow these instructions can result in injury or equipment damage.**

## General Information

The APC by Schneider Electric NetBotz Room Monitor 755 functions as the central hardware appliance for a NetBotz security and environmental monitoring system. The appliance includes the following features:

- Multiple ports for connecting APC and third-party sensors and devices.
- Ports that provide power to or allow control over other devices.
- The ability to add sensor pods to increase monitored space.

The *NetBotz® Room Monitor 755 Installation and Quick Configuration Manual* describes how to install a NetBotz Room Monitor 755, connect devices to the appliance, and configure network settings. After performing the configuration procedures in this manual, you can access your system through a Web User Interface (UI) or Representational State Transfer Application Programming Interface (REST API), perform additional configuration tasks, and begin monitoring the environment.

### **NOTICE**

The equipment contains, and the software enables, visual recording capabilities, the improper use of which may subject you to civil and criminal penalties. Applicable laws regarding the use of such capabilities vary between jurisdictions and may require, among other things, express written consent from recorded subjects. You are solely responsible for insuring strict compliance with such laws and for strict adherence to any/all rights of privacy and personalty. Use of this software for illegal surveillance or monitoring shall be deemed unauthorized use in violation of the end user software agreement and result in the immediate termination of your license rights thereunder.

---

## Additional Options

The following sensors and devices are compatible with the Room Monitor 755. For more information about any of these options, contact your APC by Schneider Electric representative or the distributor from whom you purchased your product.

- NetBotz Rack Sensor Pod 150 (NBPD0150)
- NetBotz Room Sensor Pod 155 (NBPD0155)
- NetBotz Camera Pod 165 (NBPD0165)
- NetBotz Rack Access Pod 170 (NBPD0171, NBPD0172)
- Temperature Sensor (AP9335T)
- Temperature/Humidity Sensor (AP9335TH)
- Temperature/Humidity Sensor with Digital Display (AP9520TH)
- NetBotz Spot Fluid Sensor (NBES0301)
- NetBotz Door Switch Sensor for Rooms or Third Party Racks (NBES0302)
- NetBotz Door Switch Sensor for APC by Schneider Electric Racks (NBES0303)
- NetBotz Dry Contact Cable (NBES0304)
- NetBotz 0-5 V Sensor Cable (NBES0305)
- NetBotz Vibration Sensor (NBES0306)
- NetBotz Smoke Sensor (NBES0307)
- NetBotz Rope Leak Sensor (NBES0308)
- NetBotz Rope Leak Extension (NBES0309)
- NetBotz USB Coordinator & Router (NBWC100U)
- NetBotz Wireless Temperature Sensor (NBWS100T and NBWS100H)

## Updates and Related Documents

You can find updates to this document, the *User Guide*, and the *Release Notes* on the applicable product page of the APC by Schneider Electric website, [www.apc.com](http://www.apc.com).



# Inventory

## Room Monitor 755

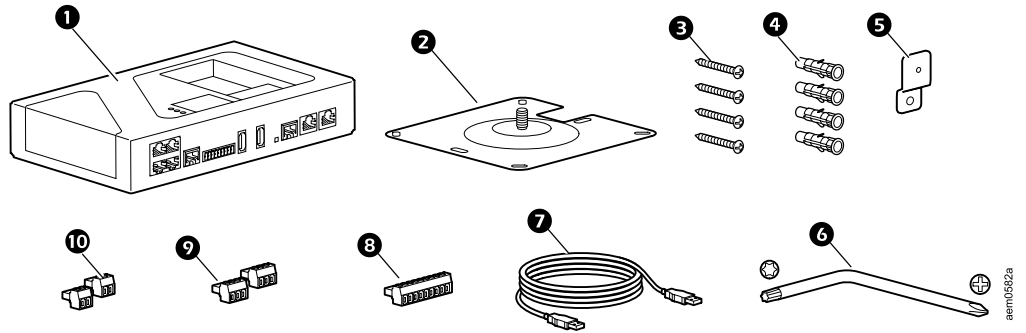

Item	Description	Quantity
1	Room Monitor 755	1
2	Mounting plate	1
3	Phillips-head screw, #8 X 1 1/2 in	4
4	Wall anchor, #8 X 1 3/8 in	4
5	Mounting bracket	1
6	TORX T30 / #2 Phillips head wrench	1
7	USB-A to Micro USB-B cable, 2 m (6 ft)	1
8	9-position terminal block plug	1
9	3-position terminal block plug	2
10	2-position terminal block plug	2

## Camera Pod 165

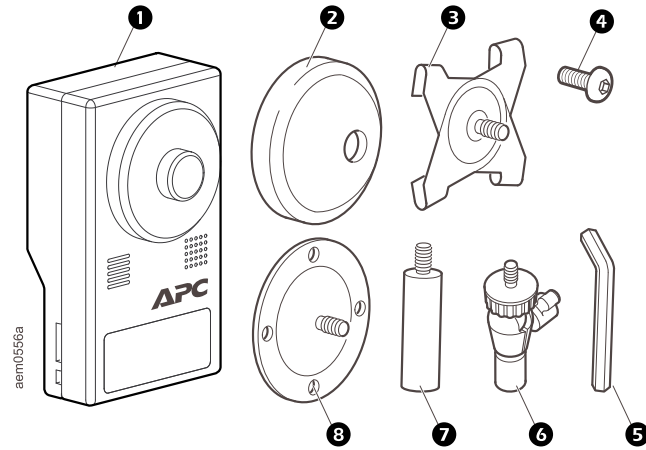

Item	Description	Quantity
1	Camera Pod 165 (NBPD0165)	1
2	Rubber bracket cover (used only for the Camera Pod 165, not the Room Monitor 755)	1
3	T-bar mounting plate (used only for the Camera Pod 165, not the Room Monitor 755)	1
4	Set screw (not used)	1
5	Hex wrench (not used)	1
6	Ball-joint adjuster arm	2
7	Extender arm	2
8	Mounting plate (used only for the Camera Pod 165, not the Room Monitor 755)	1

## Physical Description

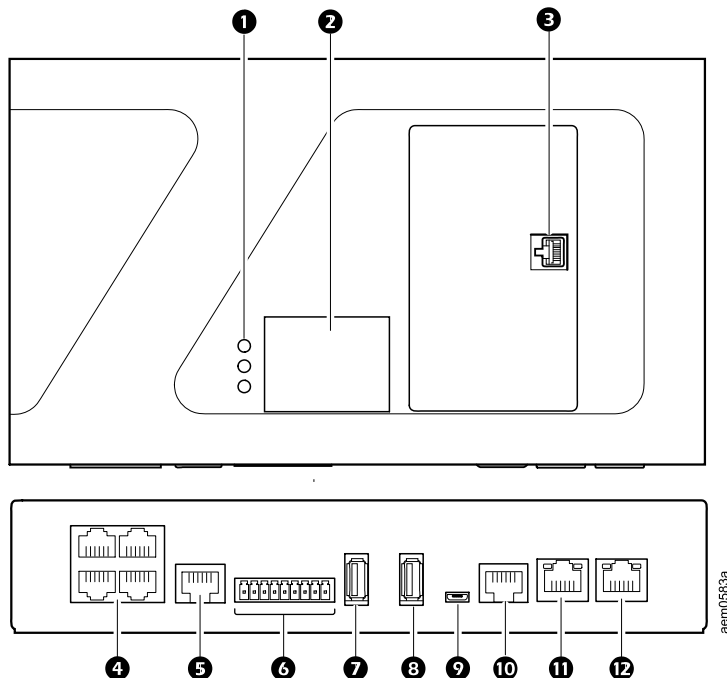

Item	Description
1	Light-emitting Diodes (LEDs) Top (green): On = power on. Off = power off. Middle (yellow): Reserved for future use. Bottom (red): Flashing red = at least one Critical or Warning alarm is active. Off = no alarms, or the appliance is off.
2	Front LED Display Displays readings from connected sensors. Flashes when Warning or Critical alarms are active.
3	RJ-45 Coupler Connection for included Camera Pod 165 unit. See <i>Installation</i> , page 13.
4	Universal Sensor ports Used to connect APC by Schneider Electric sensors, third-party dry contact sensors, and standard third-party 0–5 V sensors. See <i>Connect Sensors and Devices</i> , page 16 for connection requirements.
5	Leak Rope port Used to connect a Leak Rope sensor (NBES0308).
6	Voltage output Provides 12 VDC or 24 VDC (75 mA) to one connected device. Relay outputs Used for connecting relay-controlled external devices.
7	USB port Reserved for future use.
8	USB port for Wireless Coordinator (NBWC100U) A Wireless Coordinator & Router (NBWC100U) can be connected here to communicate with the wireless sensor network.
9	Console port Provides a serial connection to the appliance.
10	A-Link port Used to cascade NetBotz sensor pods, rack access pods, and temperature and humidity sensors with digital displays. Provide communications and power to the connected devices over standard CAT-5 cabling with straight-through wiring. For details, see <i>Cascade Sensors and Pods from A-Link Ports</i> , page 17.
11	Private LAN Provides a 10/100/100 connection to a Local Area Network (LAN). Status and Link LEDs indicate network traffic (see <i>Status LED</i> , page 12 and <i>Link (10/100/1000) LED</i> , page 12).
12	Public LAN Input power connection and public LAN connection. Use Shielded CAT-5 cables. See <i>Power and Network Connections</i> , page 15 for power source requirements. Status and Link LEDs indicate network traffic (see <i>Status LED</i> , page 12 and <i>Link (10/100/1000) LED</i> , page 12).

## Status LED

The LED on the right side of any network port indicates the status of the appliance.

Condition	Description
Off	One of the following situations exists: <ul style="list-style-type: none"> <li>The appliance is not receiving input power.</li> <li>The appliance is not operating properly. It may need to be repaired or replaced. Contact Customer Support at <a href="http://www.apc.com/support">www.apc.com/support</a>.</li> </ul>
Solid green	The appliance has valid TCP/IP settings.
Solid amber	A hardware issue has been detected. Contact customer support.
Blinking green	The appliance does not have valid TCP/IP settings.
Blinking amber	The appliance is making a boot request.
Alternately flashing green and amber	If the LED is flashing rapidly, the appliance is starting up. If the LED is flashing slowly, the appliance is waiting for a DHCP server to assign valid TCP/IP settings. (See <i>Establish Network Settings</i> , page 20 for more information.)

## Link (10/100/1000) LED

The LED on the left of any network port indicates the network speed.

Condition	Description
Off	One or more of the following situations exist: <ul style="list-style-type: none"> <li>The appliance is not receiving input power.</li> <li>The cable that connects the appliance to the network is disconnected or not functioning properly.</li> <li>The appliance is turned off or not operating correctly. It may need to be repaired or replaced. Contact Customer Support at <a href="http://www.apc.com/support">www.apc.com/support</a>.</li> </ul>
Solid green	The appliance is connected to a network operating at 1000 Megabits (Mb)/1Gigabit (Gb) per second.
Solid orange	The appliance is connected to a network operating at 10 Mb or 100 Mb per second.
Blinking green	The appliance is receiving or transmitting data packets at 1 Gb per second.
Blinking orange	The appliance is receiving or transmitting data packets at 10 Mb or 100 Mb per second.

## Care and Disposal

To clean the Room Monitor 755, gently wipe its surfaces with a clean, dry cloth. NetBotz appliances contain non-replaceable, lithium coin-cell batteries. Do not attempt to replace the battery. Consider the battery when disposing of the appliance.

# Installation

Install the Camera Pod 165, then mount the appliance to a wall or rack.

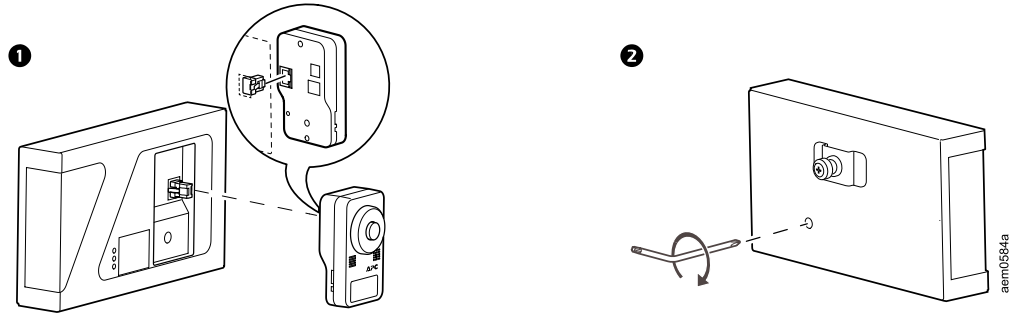

**NOTE:** Only mount the appliance right-side-up. Do not mount the appliance upside-down or sideways.

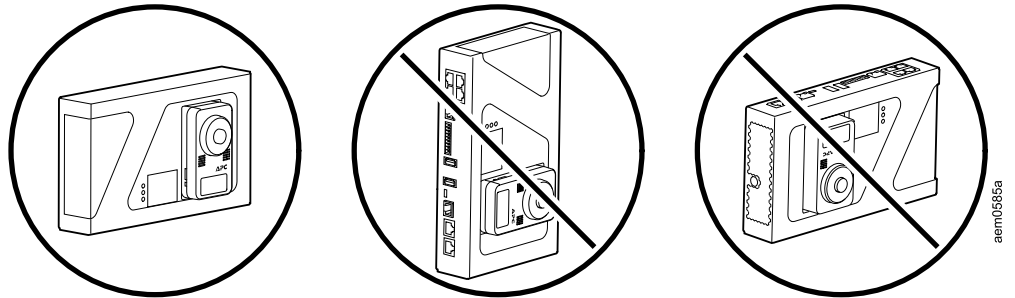

## Wall Mount

Use the provided screws and wall anchors. Drill 6.4 mm (1/4 in) holes for the wall anchors. Do not overtighten the screws.

It is recommended that you fasten at least two (2) anchors to a wall stud. For anchors in wall studs, drill the holes 38 mm (1-1/2 in) deep.

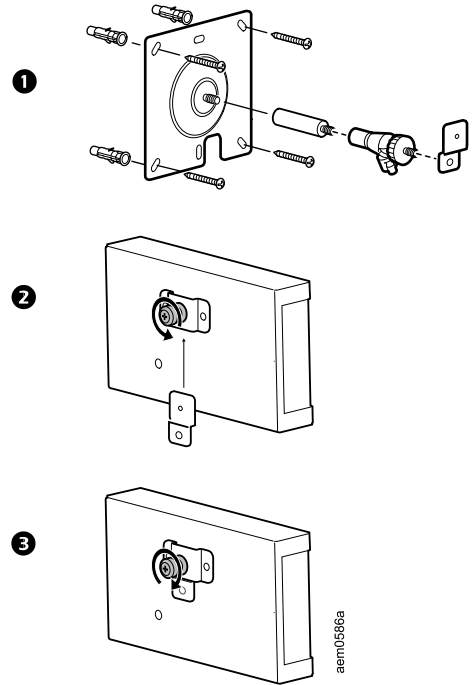

## Rack Mount

Drill 4 mm (0.16 in) pilot holes for the #8 X 1 1/2 in Phillips-head screws (provided).

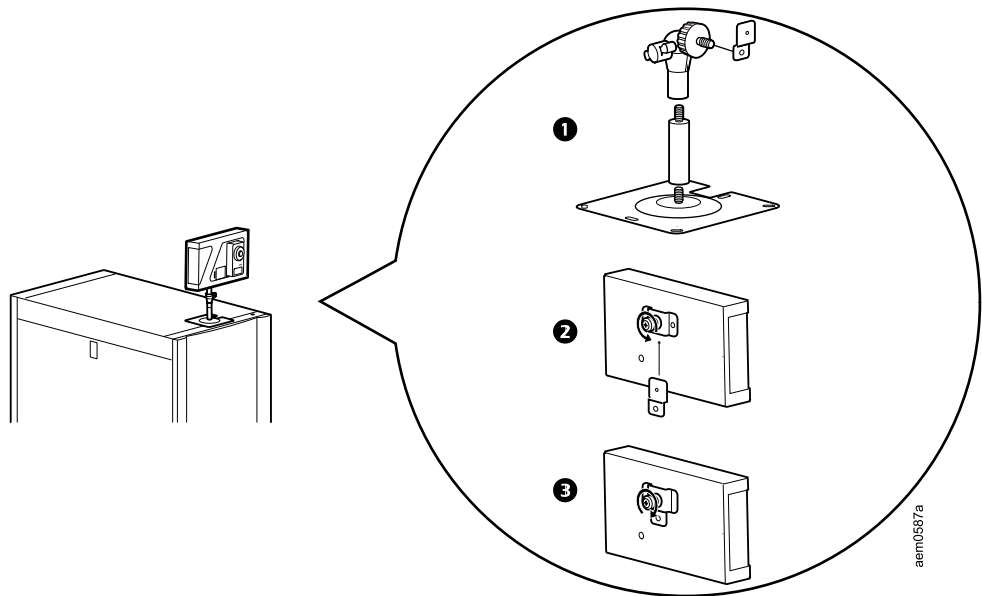

## Power and Network Connections

### NOTICE

#### EQUIPMENT DAMAGE RISK

Before you apply power to the unit, check the specifications to avoid overloading the circuit. Use shielded cables to connect your appliance to a properly grounded power source.

**Failure to follow these instructions can result in equipment damage.**

### NOTICE

If your PoE power source does not provide isolated power, the appliance may restart after the console cable is disconnected.

Using shielded, CAT-5 cables, connect the appliance to a Type 2 Power over Ethernet (PoE) injector or another Type 2 PoE device. Ensure your PoE injector or device can provide isolated power to the appliance.

#### Type 2 PoE injector connection

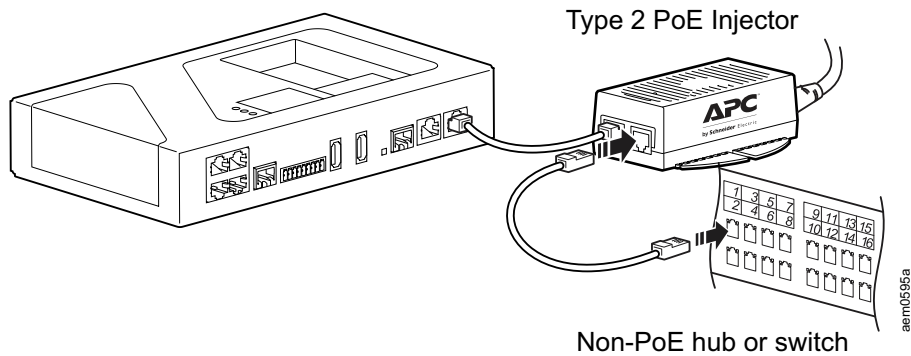

#### Type 2 PoE-enabled device connection

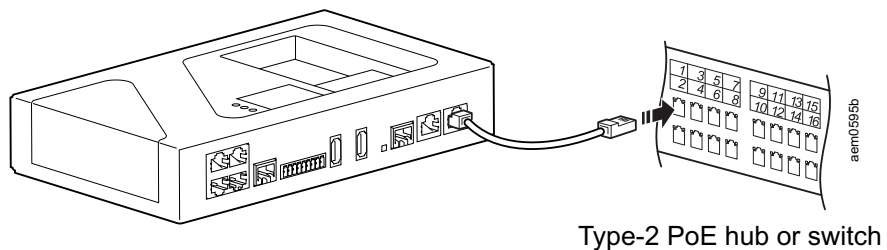

## Connect Sensors and Devices

### NOTICE

#### EQUIPMENT DAMAGE RISK

Only connect approved devices to the appropriate ports as directed in this manual.

**Failure to follow these instructions can result in equipment damage.**

The following sensors and devices connect to specific ports:

Sensor/Device	Port/connection requirements
Door switch sensors <ul style="list-style-type: none"> <li>NBES0302</li> <li>NBES0303</li> </ul>	Universal sensor ports
Downstream devices <ul style="list-style-type: none"> <li>Camera Pod 165 (NBPD0165)</li> <li>Rack PDU with Network Management Card 2 (NMC2)</li> <li>UPS with NMC2</li> </ul>	Private LAN port. (See <i>Connect Downstream Devices</i> , page 27)
Rack Access Pods <ul style="list-style-type: none"> <li>NBPD0171</li> <li>NBPD0172</li> </ul>	A-Link ports (See <i>Cascade Sensors and Pods from A-Link Ports</i> , page 17. See the <i>User Guide</i> on <a href="http://www.apc.com">www.apc.com</a> for instructions to configure rack access.)
Sensor Pods <ul style="list-style-type: none"> <li>Sensor Pod 150 (NBPD0150)</li> <li>Sensor Pod 155 (NBPD0155)</li> </ul>	A-Link ports (See <i>Cascade Sensors and Pods from A-Link Ports</i> , page 17.)
Temperature sensors <ul style="list-style-type: none"> <li>Temperature/Humidity Sensor with Display (AP9520TH)</li> <li>Temperature Sensor (AP9335T)</li> <li>Temperature/Humidity Sensor (AP9335TH)</li> </ul>	A-Link ports (See <i>Cascade Sensors and Pods from A-Link Ports</i> , page 17.) Universal sensor ports
Other NetBotz Sensors <ul style="list-style-type: none"> <li>Vibration Sensor (NBES0306)</li> <li>Smoke Sensor (NBES0307)</li> <li>Spot Fluid Sensor (NBES0301)</li> <li>0–5 V Sensor Cable (NBES0305)</li> <li>Dry Contact Cable (NBES0304)</li> </ul>	Universal sensor ports
Third-party 0–5 V sensors	Standard third-party 0–5 V sensors require the NetBotz 0–5 V Sensor Cable (NBES0305). To connect a sensor to the cable, follow the instructions provided with the sensor and the instructions provided with the cable.
Third-party dry contact sensors	Third-party dry contact sensors require the NetBotz Dry Contact Cable (NBES0304). To connect a sensor to the cable, follow the instructions provided with the sensor and the instructions provided with the cable.
<b>NOTES:</b>	
<ol style="list-style-type: none"> <li>You can also connect sensors to the universal sensor ports on a Sensor Pod 150 or 155.</li> <li>If a sensor cable is not long enough, use an RJ-45 coupling (provided with some sensors) and standard CAT-5 cabling to extend the cable up to 15 m (50 ft) for a Temperature/Humidity Sensor (AP9335TH) or a Temperature Sensor (AP9335T), and up to 30.5 m (100 ft) for all other supported sensors.</li> </ol>	



## Cascade Sensors and Pods from A-Link Ports

### NOTICE

#### EQUIPMENT DAMAGE RISK

- Do not use crossover cables.
- Do not cascade appliances. Use one appliance per system.
- Do not connect A-Link devices to an Ethernet bus.

**Failure to follow these instructions can result in equipment damage.**

A-Link is an APC by Schneider Electric proprietary Controller Area Network (CAN) bus. Devices compatible with A-Link are not Ethernet devices and cannot coexist on an Ethernet bus with other networking devices, such as hubs and switches.

Before performing this procedure, follow the installation instructions provided with the devices you plan to cascade. You can cascade any or all of the following:

- A combined total of four (4) NetBotz Rack Sensor Pod 150 (NBPD0150) units and NetBotz Room Sensor Pod 155 (NBPD0155) units. You can add up to 12 sensor pods by connecting a supplemental power supply (AP9505i) to every fourth pod.
- A combined total of twelve (12) Temperature Sensors with Digital Display (AP9520T) and Temperature/Humidity Sensors with Digital Display (AP9520TH).
- One (1) rack access pod (NBPD0171, NBPD0172) with one supplemental power supply (AP9505i) attached.

To connect sensors and sensor pods to A-Link ports,

1. Connect sensors and sensor pods to the appliance as shown.
  - Connect to in and out ports as shown.
  - The combined length of all A-Link cables (❶) must not exceed 1000 m (3,280 ft).
  - Use CAT-5 (or equivalent) Ethernet patch cables (❷).
2. Plug an A-Link terminator (❸) into the unused A-Link port.
3. Connect supplemental power supplies (AP9505i) to the 24 VDC Inputs on your devices as required.

**NOTE:** The first time a sensor pod receives power, it obtains a unique identification address for communication over the A-Link bus. To avoid communication problems, complete steps 1 and 2 before you connect a supplemental power supply.

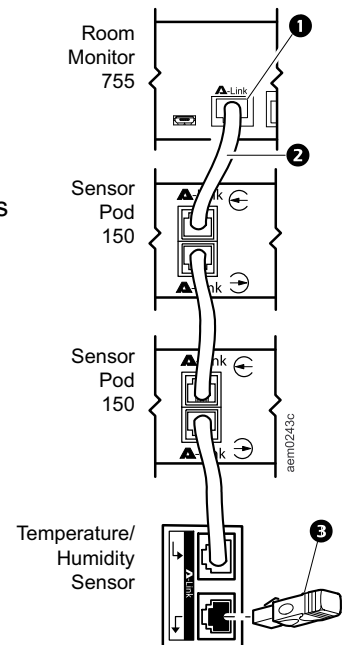

## The Wireless Sensor Network

The wireless sensor network is made of a host appliance, a coordinator, routers, and end devices.

- The **host appliance** (your NetBotz Rack Monitor or Room Monitor) collects data from the wireless sensor network and generates alerts based on sensor readings.
- The **coordinator** is connected directly to the host appliance via USB. It reports data from the sensors on the network and provides available firmware updates to the wireless network. Each wireless sensor network must have only one coordinator, which is connected to a dedicated USB Type A port on the appliance.
- **Routers** extend the range of the wireless sensor network. Routers pass information between themselves and the coordinator, and between the coordinator and end devices. Each router is powered by an AC-USB adapter, not directly connected to the host appliance.

Routers are optional. In a data center environment where obstructions are common, routers are recommended if sensors are more than 15 m (50 ft) from the coordinator.

- **End devices** monitor attached and internal sensors and send data back to the host appliance. End devices are powered by batteries, and are not connected to the host appliance.

### Devices on the Wireless Sensor Network

#### **NOTICE**

##### **EQUIPMENT DAMAGE RISK**

Only the devices listed here are compatible with the NetBotz wireless sensor network. Other devices may not function and may damage the appliance or other wireless devices.

**Failure to follow these instructions can result in equipment damage.**

Device	Network Role
USB Coordinator & Router (NBWC100U)	Coordinator when connected to the appliance USB port  Router when connected wirelessly and powered by an AC-USB adaptor
Wireless Temperature Sensor (NBWS100T)	End device
Wireless Temperature/Humidity Sensor (NBWS100H)	End device

**NOTE:** Wireless devices have a range of up to 30.5 m (100 ft), line of sight. In a data center environment where obstructions are common, a range of 15 m (50 ft) is typical for any wireless device.

## Connect the Wireless Sensor Network

The order in which you configure your wireless sensor network and apply power to your wireless devices is important:

1. Select the coordinator and routers. Note the extended address of the coordinator. If necessary, choose one or more USB Coordinator & Routers to become routers.
2. Choose the locations for the routers and end devices. Do not turn on the routers or end devices at this time.
3. Connect the Coordinator to the designated USB port on the NetBotz appliance.
4. Use an AC-USB adapter to apply power to each router. Routers are not directly connected to the NetBotz appliance.
5. Turn on the end devices after the coordinator and routers. This helps to preserve battery life.
6. Add end devices (wireless sensors) to the wireless sensor network. See *Add Sensors to the Wireless Sensor Network*, page 26 for instructions.

# Initial Configuration

## Establish Network Settings

You must configure the following TCP/IP settings before the appliance can operate on a network:

- IP address of the appliance
- Subnet mask
- Default gateway
- At least one IP address for a Domain Name System (DNS) server

By default, your appliance uses Dynamic Host Configuration Protocol (DHCP) to configure network settings. When you apply power to the appliance, it automatically attempts to contact a DHCP server.

You can use a computer to view the DHCP settings or configure the network settings manually. If needed, you can also view or configure network settings with a terminal emulator.

## Use Your Computer to Establish Network Settings

1. Use the Public LAN port to connect your appliance to the network.
2. Ensure your computer is set to obtain network settings via DHCP. Connect a network cable from your computer to a Private LAN port on the appliance. Wait about five (5) minutes for the computer to establish a working Ethernet connection through the appliance.  
**NOTE:** Some computers are configured to prevent simultaneous connections to Ethernet and Wi-Fi, so you may need to disable Wi-Fi before connecting to the appliance.
3. For Windows® or Linux® systems, open a command prompt to view the default gateway, then enter the default gateway in your Web browser's URL address bar. The following commands allow you to view the default gateway:
  - Windows: `ipconfig`
  - Linux: `route -n`

For Macintosh® systems, open the network preferences for your Ethernet connection. Enter the **Router** address in your Web browser's URL address bar. The default gateway or router address takes you to the appliance Web UI.

**NOTE:** You may receive a message that the Web page is not secure. This is normal, and you can continue to the Web UI. See *Access the Web User Interface (Web UI)*, page 23 for more information.

4. Use the default user name and password (both are **superuser**) to log on to the appliance, and change the password when prompted. It is recommended that you use a strong password that complies with your company's password requirements.
5. Go to **Settings > System > Network** to view or configure the network settings for your appliance.

Setting	Description
<b>Static</b>	Select <b>Static</b> to manually configure your Network settings. This setting assigns a static IP address to the appliance.
<b>DHCP</b>	Use a DHCP server to configure network settings automatically. This setting assigns a dynamic IP address to the appliance.
<b>Hostname</b>	The host name of the appliance.
<b>TCP/IP</b>	
<b>IP Address</b>	The IP address of the appliance. Use the format xxx.xxx.xxx.xxx.
<b>Subnet Mask</b>	The subnet mask of the appliance.
<b>Gateway</b>	The IP address of the default gateway.
<b>DNS</b>	
<b>Primary</b>	The IP address of the primary DNS server
<b>Secondary</b>	The IP address of the secondary DNS server
<b>Tertiary</b>	The IP address of the tertiary DNS server

Click **Apply** to save your changes.

6. Test the IP connection of the appliance: Close the Web UI and disconnect your computer from the appliance. Start your Web browser and type the IP address of the appliance into the URL address bar. Press **Enter**. If the appliance is online and properly configured, the Web UI displays in the browser window.

---

## Use a Terminal Emulator to Establish Network Settings

1. Connect a USB-A to Micro USB-B cable to the Console Port on the NetBotz appliance and a USB port on your computer.
2. Use a PoE-ready ethernet cable to connect the appliance to power.  
The green Power LED illuminates. The appliance can take up to two (2) minutes to initialize, depending on configuration settings.
3. Open a serial connection on your terminal emulator using port settings 115,200 baud, 8 data bits, no parity, 1 stop bit, and no flow control.
4. Press **Enter**, repeatedly if necessary, to display the `User Name` prompt. If you are unable to display the `User Name` prompt, verify the following:
  - The serial port is not in use by another application.
  - The terminal settings are correct as specified in step 3.
  - The correct cable is being used as specified in step 2.
  - The Silicon Labs CP210x driver is installed on your computer. (You can find the driver on [www.silabs.com](http://www.silabs.com).)
5. Log on with the Root account user name (**root**) and password (you set the password on first use).
6. Configure your appliance to use network settings assigned by a DHCP server, or provide an IP address, subnet mask, gateway address, and at least one IP address for a DNS server.
7. Save your configuration settings, and close the terminal emulator.
8. Test the IP connection of the appliance: start your Web browser and type the IP address of the appliance into the URL address bar. Press **Enter**. If the appliance is online and properly configured, the Web UI displays in the browser window.

**NOTE:** You may receive a message that the Web page is not secure. This is normal, and you can continue to the Web UI. See *Access the Web User Interface (Web UI)*, page 23 for more information.

## Access the Appliance

After the network settings are configured, you can access the appliance through the Web UI and REST API. The Web UI provides a real-time overview of alerts and device details, including sensor readings and images captured by cameras. The REST API allows you to interact with the appliance via JavaScript Object Notation (JSON) requests. See the *User Guide* on [www.apc.com](http://www.apc.com) for detailed instructions on using the Web UI and REST API.

**NOTE:** The Web UI and REST API take about six minutes to become available after start-up.

### Access the Web User Interface (Web UI)

After the network settings are configured, you can access the appliance through the Web UI. The Web UI provides a real-time overview of alerts and device details, including sensor readings and images captured by cameras. You can use Microsoft Internet Explorer® (IE) 11 or the latest version of Google Chrome® or Mozilla Firefox® on Windows® 7 and 10 operating systems to access the appliance through its Web UI. Other commonly available browsers and operating systems may work but have not been fully tested.

**NOTE:** Camera streaming is not supported in IE 11.

1. Enter the host name or IP address of the appliance in the Web browser's URL address bar. (If you used DHCP to automatically obtain the IP address of the appliance, you can use your computer or a terminal emulator to view your current IP address. Follow steps 1-4 of *Use Your Computer to Establish Network Settings*, page 20 or 1-5 of *Use a Terminal Emulator to Establish Network Settings*, page 22.) You may receive a message that the Web page is not secure. This is normal when using a self-signed certificate (the default), and you can continue to the Web UI.

**NOTE:** Your appliance comes with a self-signed certificate installed. Browsers generate a security warning because they do not recognize the authority who signed the certificate. You can prevent the warning message by installing a certificate signed by a Certificate Authority (CA) the Web browser recognizes (see the *User Guide* on [www.apc.com](http://www.apc.com) for more information). You can also direct the browser to accept the certificate to prevent the warning.

2. Use your user name and case-sensitive password to log on. The default user name and password for the Super User are both **superuser**. The Super User must define the user name and password for Administrators.

Both the Super User and Administrators must change their passwords at first log on. Use strong passwords that comply with your company's password requirements.

## REST API

To access the online REST API documentation, log on to the Web UI, then open a new tab and enter

```
your_appliance_IP_address/docs/rest
```

in the URL address bar.

To access the REST API, enter *your\_appliance\_IP\_address/rest*.

For more information about the REST API, see the *User Guide* on *www.apc.com*.

## Types of User Accounts

The appliance has three types of user accounts:

- Use the **Super User** account to log on to the Web UI after initial configuration. The super user can create, edit, or delete administrators.  
The default user name and password for this account are both **superuser**. The Super User is required to change the Super User password the first time they log on.
- **Administrators (admins)** are required to change their passwords when they first log on to the appliance. Admins can not create or edit other accounts.
- Use the **Root** account for procedures that require using the Console Port, e.g., using a terminal emulator to specify network settings. You set the default password the first time you log on. You cannot change the default user name (**root**).

## Reset a Lost Super User Password

1. Connect to the appliance with SSH or through the console port on your computer. Log on with the root account user name and password, then press **Shift + x Enter** within five (5) seconds of logging on.
2. Navigate to `/netbotz_app` and enter the following command:  

```
./restart.sh stop startApp startClubber resetsupwd
```

The application restarts.
3. Log on to the appliance as the Super User (both the user name and password are **superuser**).
4. Change the default password.



## Reset a Lost Root Account Password

1. Connect a USB-A to Micro USB-B cable to the Console Port on the NetBotz appliance and a USB port on your computer. Open a serial connection on your terminal emulator using port settings 115,200 baud, 8 data bits, no parity, 1 stop bit, and no flow control.
2. Disconnect and reconnect power to the appliance. Immediately press any key on your computer. If you do not press a key within five seconds after you connect power to the appliance, the appliance will restart normally.  
You will see the following prompt: `SNARC_SOCA9_BESTLA_2G #`.
3. Enter the following three commands:

```
env set resetpwd true
env save
boot
```

Wait for the system to restart.

4. Log on as the Root user. When prompted, reset the Root account password.
5. Disconnect and reconnect power to the appliance. Immediately press any key on your computer. If you do not press a key within five (5) seconds after you connect power to the appliance, the appliance will restart normally.
6. Enter the following three commands:

```
env set resetpwd
env save
boot
```

Wait for the system to restart. Log on as the Root user.

**NOTE:** If you do not complete steps 5 and 6, you will be required to reset the Root password every time you access the console after the appliance restarts.

## Reset to Defaults

This procedure reboots the appliance and resets all system settings (including passwords) to factory defaults.

**NOTE:** This procedure causes the appliance IP address to be reset. In some cases, you may lose access to the appliance and may need to use a local connection to reset or rediscover the IP address.

1. Log into the Web UI as the Super User.
2. Open a new browser page, type

`<your appliance's IP address>/rest/appliance/resetconfig`  
in the URL address bar, then press **Enter**.

**Example:** `10.218.123.234/rest/appliance/resetconfig`

The appliance takes about six (6) minutes to restart completely. Until the restart is complete, the Web UI is not available.

3. If needed, see *Use Your Computer to Establish Network Settings, page 20* or *Use a Terminal Emulator to Establish Network Settings, page 22* for instructions to discover or change the IP address.

---

## Add Sensors to the Wireless Sensor Network

Follow the instructions to *Connect the Wireless Sensor Network*, page 19. Then, in the **Wireless** tab, click **ADD**, and select one of the following.

### Add Detected Sensors

1. Select any automatically detected device, or use the **Search** field to find the MAC address for a specific end device. You can enter a name for any selected sensor in the **Name** field.
2. Click **ADD** to add all selected sensors to the wireless sensor network, or click **CANCEL** to close the window.

### Add Sensors Manually

1. Click **Choose File** to navigate to a CSV file saved on your computer, or type the MAC address of the device in the **MAC Address** field. You can enter a name for any selected sensor in the **Name** field. If you do not give the sensor a name, its MAC address is used as the name.

**NOTE:** The CSV format for each sensor should be *MAC address, optional name*.

2. Select **Add another** to add more than one sensor, or click Remove  to remove a sensor from the list. You can enter the name or MAC address of a specific sensor in the **Search** field to highlight it.
3. Click **ADD** to add all listed sensors to the wireless sensor network, or click **CANCEL** to close the window.

**NOTE:** Wireless devices show as **Disconnected** until they establish communication with the appliance.

## Connect Downstream Devices

Compatible downstream devices include APC by Schneider Electric Rack Power Distribution Units (RPDUs) with Network Management Cards (NMC2), Smart UPS (Uninterruptable Power Supply) units, or NetBotz Camera Pod 165 units. Other ONVIF cameras may work but have not been tested.

To connect downstream devices, go to **Settings > System > Device Credentials**, and configure the following settings to match the settings on your device:

Setting	Description
<b>Camera (ONVIF)</b>	
<b>NOTE:</b> If you have not already set a password on a Camera Pod 165, you do not have to set the ONVIF credentials for that unit. The appliance will assign it a password.	
<b>Username</b>	The user name to access the camera..
<b>Password/Confirm Password</b>	The password to access the camera.
<b>SNMPv1</b>	
<b>Read-only community name</b>	The name used to access the Read-only community.
<b>Read-Write community name</b>	The name used to access the Read-write community.
<b>SNMPv3</b>	
<b>Username</b>	The identifier of the user profile.
<b>Authentication/Encryption</b>	Select whether to use <b>No security</b> , <b>Authentication only</b> , or both <b>Authentication</b> and <b>Encryption</b> .
<b>Authentication</b>	Verifies that the device communicating through SNMPv3 is the device claims to be, that the message has not been changed during transmission, and that the message was communicated in a timely manner, indicating that it was not delayed and that it was not copied and sent again later at an inappropriate time.
<b>Protocol</b>	<b>SHA1:</b> Slower, but more secure than MD5 <b>MD5:</b> Faster, but less secure than SHA1
<b>Password/Confirm Password</b>	The password or passphrase used for authentication.
<b>Encryption</b>	Encrypts the data sent over SNMPv3.
<b>Protocol</b>	<b>AES-128:</b> More secure than DES. Uses a 128-bit key to encrypt data. <b>DES:</b> Less secure than AES. Uses a 56-bit key.
<b>Password/Confirm Password</b>	The password or passphrase used for encryption.

Then connect the devices to your appliance through a Private LAN port. You can connect a network switch or hub to the Private LAN port to connect up to ten (10) downstream devices, including up to four (4) cameras. Performance may vary depending on the amount of video recorded or the number of sensors attached to your downstream devices.

**NOTE:** The appliance counts disconnected devices as supported units. Use the  icon to remove devices before replacing them with new ones.

If a Camera Pod 165 has previously been connected remotely (or connected to another appliance), reset the camera while it is connected to the appliance. If the camera does not appear after 10 minutes, disconnect the camera, remove it from the Web UI, then re-connect it. If you do not reset the camera, it may take hours or days to appear in the Web UI (the time depends on your company's DHCP configuration).

**NOTE:** See the *User Guide* on [www.apc.com](http://www.apc.com) for instructions to connect Camera Pods remotely.

Once your devices are communicating with the appliance, you can change the **Device Credentials** to match a new set of devices without losing the established devices.

## Control Devices by Outlet

Outlet-controlled devices include devices connected to the relay output port. You can select an outlet-controlled device to view its current status, or manually change the status of the device (from **inactive** to **active** or from **active** to **inactive**).

## Configure Alarms

**NOTE:** The options available depend on your appliance and which sensors are connected to it.

You can use the **Alarm Configuration** page (under **Settings > Alarm Configuration**) to edit the default alarms, create new alarms, or delete alarms. If you create new alarms, you must add sensors to the new alarms manually. Select **Edit**  to change an existing alarm configuration, or click **ADD** and select the sensor type to create a new alarm. Then configure the alarm settings.

Setting	Description
<b>Name</b>	The name of the alarm. This appears on the alarm configuration page, the <b>Alarms</b> tab, and the relevant sensor details window when the alarm is generated.
<b>Operation</b>	<p><b>Greater than:</b> If the device returns a value greater than the <b>Value</b> field, the alarm is generated.</p> <p><b>Less than:</b> If the device returns a value less than the <b>Value</b> field, the alarm is generated.</p> <p><b>Equals:</b> If the device returns a value equal to the <b>Value</b> field, the alarm is generated.</p>
<b>Value</b>	<p>The alarm is based on this value. Available values depend on the selected type of device.</p> <p><b>Battery:</b> Enter a value in Volts (V).</p> <p><b>0V-5V:</b> Enter a value in Volts (V).</p> <p><b>Humidity:</b> Enter a percent value.</p> <p><b>Motion:</b> Select <b>No Motion</b> or <b>Motion Detected</b>.</p> <p><b>Output Relay:</b> Select <b>Active</b> or <b>Inactive</b>.</p> <p><b>RSSI:</b> Enter a value in decibels (dB).</p> <p><b>Temperature:</b> Enter a value in degrees Fahrenheit or Celsius. The temperature scale is determined in your user settings (see the <i>User Guide</i> on <a href="http://www.apc.com">www.apc.com</a>).</p>
<b>Severity</b>	Select the severity of the alarm: <b>Critical</b> , <b>Warning</b> , or <b>Informational</b> .
<b>Sensors</b>	Select any sensors that can cause the alarm to be generated.
<b>Clip Capture</b>	This feature is optional. Select a camera to capture video from before and after the alarm is generated. The captured video will appear in the details window for any device that causes an alarm.
<b>Control</b>	<p>This feature is optional. Determine how other connected devices are affected by the alarm. Under <b>Name</b>, select devices the alarm will control. Under <b>On alarm active</b> and <b>On alarm clear</b>, select what will happen when the alarm activates and is cleared (respectively).</p> <p>For example, if you select <b>Beacon at appliance</b>, the beacon attached to your appliance will be controlled by the alarm. If you select <b>On</b> under <b>On alarm active</b> and select <b>Off</b> under <b>On alarm clear</b>, the beacon turns on when the alarm is generated and turns off when the alarm is cleared.</p>
<b>Schedule</b>	Select <b>Schedule</b> , then select times during which the alarm can be generated. The alarm can not be generated during times that are not selected.

Click **OK** to save the alarm configuration, or **CANCEL** to discard it.

To delete an alarm, select  Delete.

**NOTE:** See the *User Guide* on [www.apc.com](http://www.apc.com) for more detailed information about alarm configuration and default alarms.

## Update the Firmware

1. Download the latest firmware version for free from the APC by Schneider Electric website, [www.apc.com](http://www.apc.com).
2. Under **Settings > Firmware Update**, click **Choose File**, navigate to the firmware file on your computer, and select **Open**. Do not close the page while the file is uploading, or the upload will be aborted. (You can work in a different tab or a different browser window.)
3. Click **INSTALL** to install the firmware, or **Start Again** to select a different firmware version. Users can not access the Web UI while the firmware is updating. The appliance restarts when the upload is finished. This process can take about 30 minutes.

# Specifications

## Appliance Specifications

<b>Electrical</b>	
Input voltage, nominal	48 VDC
Maximum total current draw	640 mA
<b>Physical</b>	
Dimensions (H x W x D)	140 x 244 x 91.28 mm (5.5 x 9.6 x 3.6 in) with Camera Pod 165 installed
Weight	1.56 kg (3.44 lb)
<b>Environmental</b>	
Elevation (above MSL) Operating Storage	0 to 3000 m (0 to 10,000 ft) 0 to 4 572 m (0 to 15,000 ft)
Temperature Operating Storage	0 to 40°C (32 to 104°F) -5 to 55°C (23 to 131°F)
Humidity Operating Storage	0 to 95%, non-condensing 0 to 95%, non-condensing
<b>Compliance</b>	
cULus-EU/CE	<ul style="list-style-type: none"> <li>• IEC 60950-1:2005/AMD1:2009, IEC 60950-1:2005/AMD2:2013, IEC 60950-1:2005</li> <li>• IEC/EN/CSA/UL 60950-1:2006/A11:2009/A1:2010/A12:2011/A2:2013</li> <li>• IEC/EN/CSA/UL 62368-1 2nd Ed.</li> <li>• UL/EN62368-1:2014+A11:2017</li> <li>• LVD 2014/35/EU</li> </ul>
<b>EMC Compliance</b>	
FCC	47 CFR PART 15 CLASS A
ICES	ICES-003:2012 CLASS A
CE	EMC 2014/30/EU
AS/NZ	CISPR 22
VCCI	V-3:2015

## Sensor Specifications

<b>3.65 m (12 ft) Door Switch Sensor for APC Racks (NBES0303), 15.24 m (50 ft) Door Switch Sensor for Rooms or Third Party Racks (NBES0302)</b>	
User input response times	200 mS
Maximum cable length	30.48 m (100 ft)
Gap distance	Less than 2.54 cm (1 in.) in air
<b>Dry Contact Cable (NBES0304)</b>	
User input response times	200 mS
Maximum cable length	30.48 m (100 ft)
<b>Temperature Sensor (AP9335T)</b>	
Temperature accuracy	$\pm 1$ °C ( $\pm 2$ °F), from 0 to 40°C (32 to 104°F)
Sensor operating temperature	-10 to 70°C (14 to 159°F)
Maximum length of cable	15.2 m (50 ft)
<b>Temperature/Humidity Sensor (AP9335TH)</b>	
Temperature accuracy	$\pm 1$ °C ( $\pm 2$ °F), from 32 to 0 to 40°C (104°F)
Humidity accuracy	$\pm 4$ % RH, 20 to 90% RH, at 25°C (77°F) $\pm 8$ % RH, 30 to 80% RH, from 15 to 30°C (59 to 95°F)
Sensor operating temperature	-10 to 70°C (14 to 159°F)

# Two-year Factory Warranty

This warranty applies only to the products you purchase for your use in accordance with this manual.

## Terms of Warranty

APC by Schneider Electric warrants its products to be free from defects in materials and workmanship for a period of two years from the date of purchase. APC by Schneider Electric will repair or replace defective products covered by this warranty. This warranty does not apply to equipment that has been damaged by accident, negligence or misapplication or has been altered or modified in any way. Repair or replacement of a defective product or part thereof does not extend the original warranty period. Any parts furnished under this warranty may be new or factory-remanufactured.

## Non-transferable Warranty

This warranty extends only to the original purchaser who must have properly registered the product. The product may be registered at [www.apc.com](http://www.apc.com).

## Exclusions

APC by Schneider Electric shall not be liable under the warranty if its testing and examination disclose that the alleged defect in the product does not exist or was caused by end user's or any third person's misuse, negligence, improper installation or testing. Further, APC by Schneider Electric shall not be liable under the warranty for unauthorized attempts to repair or modify wrong or inadequate electrical voltage or connection, inappropriate on-site operation conditions, corrosive atmosphere, repair, installation, exposure to the elements, Acts of God, fire, theft, or installation contrary to APC by Schneider Electric recommendations or specifications or in any event if the APC by Schneider Electric serial number has been altered, defaced, or removed, or any other cause beyond the range of the intended use.

**THERE ARE NO WARRANTIES, EXPRESS OR IMPLIED, BY OPERATION OF LAW OR OTHERWISE, OF PRODUCTS SOLD, SERVICED OR FURNISHED UNDER THIS AGREEMENT OR IN CONNECTION HERewith. APC BY SCHNEIDER ELECTRIC DISCLAIMS ALL IMPLIED WARRANTIES OF MERCHANTABILITY, SATISFACTION AND FITNESS FOR A PARTICULAR PURPOSE. APC BY SCHNEIDER ELECTRIC EXPRESS WARRANTIES WILL NOT BE ENLARGED, DIMINISHED, OR AFFECTED BY AND NO OBLIGATION OR LIABILITY WILL ARISE OUT OF, APC BY SCHNEIDER ELECTRIC RENDERING OF TECHNICAL OR OTHER ADVICE OR SERVICE IN CONNECTION WITH THE PRODUCTS. THE FOREGOING WARRANTIES AND REMEDIES ARE EXCLUSIVE AND IN LIEU OF ALL OTHER WARRANTIES AND REMEDIES. THE WARRANTIES SET FORTH ABOVE CONSTITUTE APC BY SCHNEIDER ELECTRIC'S SOLE LIABILITY AND PURCHASER'S EXCLUSIVE REMEDY FOR ANY BREACH OF SUCH WARRANTIES. APC BY SCHNEIDER ELECTRIC WARRANTIES EXTEND ONLY TO PURCHASER AND ARE NOT EXTENDED TO ANY THIRD PARTIES.**

**IN NO EVENT SHALL APC BY SCHNEIDER ELECTRIC, ITS OFFICERS, DIRECTORS, AFFILIATES OR EMPLOYEES BE LIABLE FOR ANY FORM OF INDIRECT, SPECIAL, CONSEQUENTIAL OR PUNITIVE DAMAGES, ARISING OUT OF THE USE, SERVICE OR INSTALLATION, OF THE PRODUCTS, WHETHER SUCH DAMAGES ARISE IN CONTRACT OR TORT, IRRESPECTIVE OF FAULT, NEGLIGENCE OR STRICT LIABILITY OR WHETHER APC BY SCHNEIDER**



**ELECTRIC HAS BEEN ADVISED IN ADVANCE OF THE POSSIBILITY OF SUCH DAMAGES. SPECIFICALLY, APC BY SCHNEIDER ELECTRIC IS NOT LIABLE FOR ANY COSTS, SUCH AS LOST PROFITS OR REVENUE, LOSS OF EQUIPMENT, LOSS OF USE OF EQUIPMENT, LOSS OF SOFTWARE, LOSS OF DATA, COSTS OF SUBSTITUENTS, CLAIMS BY THIRD PARTIES, OR OTHERWISE.**

**NO SALESMAN, EMPLOYEE OR AGENT OF APC BY SCHNEIDER ELECTRIC IS AUTHORIZED TO ADD TO OR VARY THE TERMS OF THIS WARRANTY. WARRANTY TERMS MAY BE MODIFIED, IF AT ALL, ONLY IN WRITING SIGNED BY AN APC BY SCHNEIDER ELECTRIC OFFICER AND LEGAL DEPARTMENT.**

## Warranty Claims

Customers with warranty claims issues may access the customer support network through the Support page, [www.apc.com/support](http://www.apc.com/support). Select your country from the country selection pull-down menu at the top of the Web page. Select the **Support** tab to obtain contact information for customer support in your region.

# Radio Frequency Interference

## USA—FCC

This equipment has been tested and found to comply with the limits for a Class A digital device, pursuant to part 15 of the FCC Rules. These limits are designed to provide reasonable protection against harmful interference when the equipment is operated in a commercial environment. This equipment generates, uses, and can radiate radio frequency energy and, if not installed and used in accordance with this user manual, may cause harmful interference to radio communications. Operation of this equipment in a residential area is likely to cause harmful interference. The user will bear sole responsibility for correcting such interference.

After an electrostatic discharge (ESD) event, the appliance may require up to 2 minutes to restart services that are necessary for normal operation. During this time, the Web UI of the appliance will be unavailable. If any necessary services or devices external to the appliance, such as a DHCP server, were affected by the ESD event, these devices also need to restart properly.

## Canada—ICES

This Class A digital apparatus complies with Canadian ICES-003.

Cet appareil numérique de la classe A est conforme à la norme NMB-003 du Canada.

## Japan — VCCI

This is a Class A product based on the standard of the Voluntary Control Council for Interference by Information Technology Equipment (VCCI). If this equipment is used in a domestic environment, radio disturbance may occur, in which case, the user may be required to take corrective actions.

この装置は、情報処理装置等電波障害自主規制協議会 ( VCCI ) の基準に基づくクラス A 情報技術装置です。この装置を家庭環境で使用すると、電波 妨害を引き起こすことがあります。この場合には、使用者が適切な対策を講ずるように要求されることがあります。

## Taiwan—BSMI

警告使用者:  
這是甲類的資訊產品, 在居住的  
環境中使用時, 可能會造成射頻  
干擾, 在這種情況下, 使用者會  
被要求採取某些適當的對策。

## Australia and New Zealand

**Attention:** This is a Class A product. In a domestic environment this product may cause radio interference in which case the user may be required to take adequate measures.

### **European Union**

This product is in conformity with the protection requirements of EU Council Directive 2014/30/EU on the approximation of the laws of the Member States relating to electromagnetic compatibility. APC by Schneider Electric cannot accept responsibility for any failure to satisfy the protection requirements resulting from an unapproved modification of the product.

This product has been tested and found to comply with the limits for Class A Information Technology Equipment according to CISPR 32/European Standard EN 55032. The limits for Class A equipment were derived for commercial and industrial environments to provide a reasonable protection against interference with licensed communication equipment.

**Attention:** This is a Class A product. In a domestic environment this product may cause radio interference in which case the user may be required to take adequate measures.

APC by Schneider Electric  
132 Fairgrounds Rd  
West Kingston, RI 02892  
USA

[www.apc.com](http://www.apc.com)

As standards, specifications, and design change from time to time,  
please ask for confirmation of the information given in this publication.

© 2019 – APC by Schneider Electric. All rights reserved.

990-6171A-001