

0099927A -04

circuit breaker
disjoncteur
interruptor
automático

The manufacturer assumes no responsibility for damage resulting from the non-application or incorrect application of the instructions provided herein.

Le non respect des indications de la présente notice ne saurait engager la responsabilité du constructeur.

El fabricante no se responsabiliza de los daños originados como resultado de la falta de aplicación o aplicación incorrecta de las presentes instrucciones.

Merlin Gerin
Square D
Telemecanique

**Compact
NB400-600N**

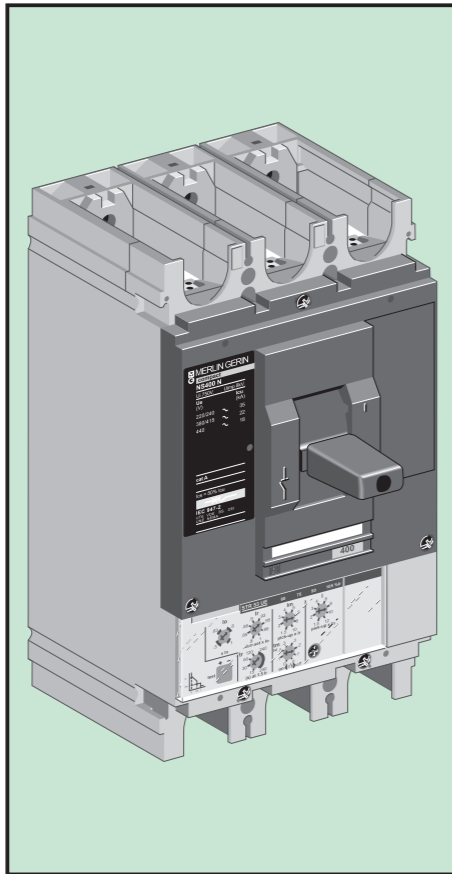

**Schneider
Electric**

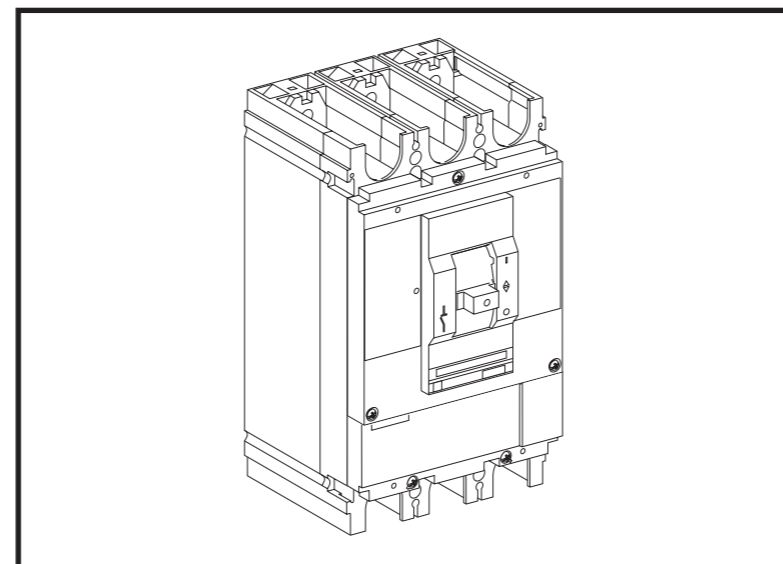

6	M10 x 27,5		
6			
4	M5 x 85		
1			

pozidriv n°1, 2
ou plat /
slotted screwdriver

mm
inch

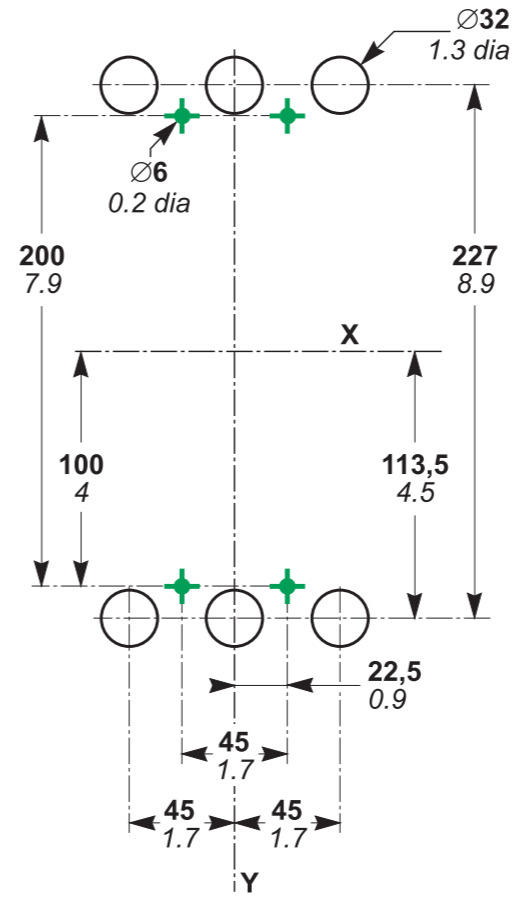

M5 x 85

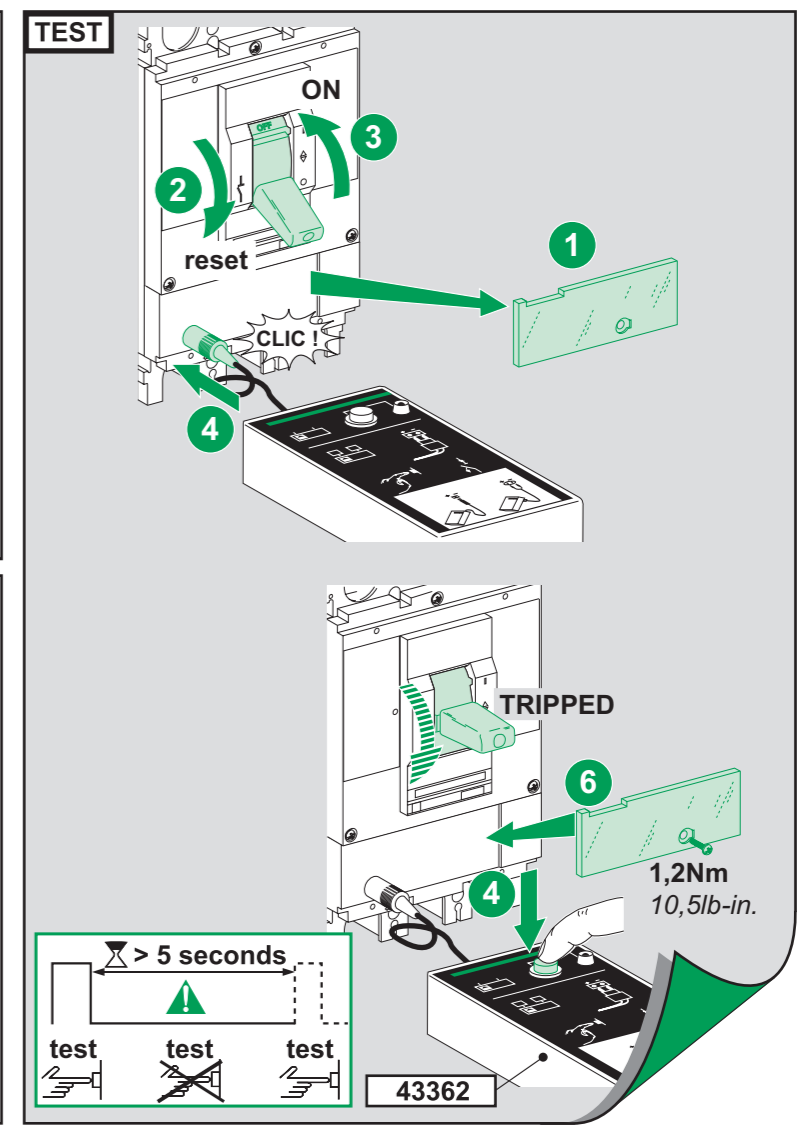
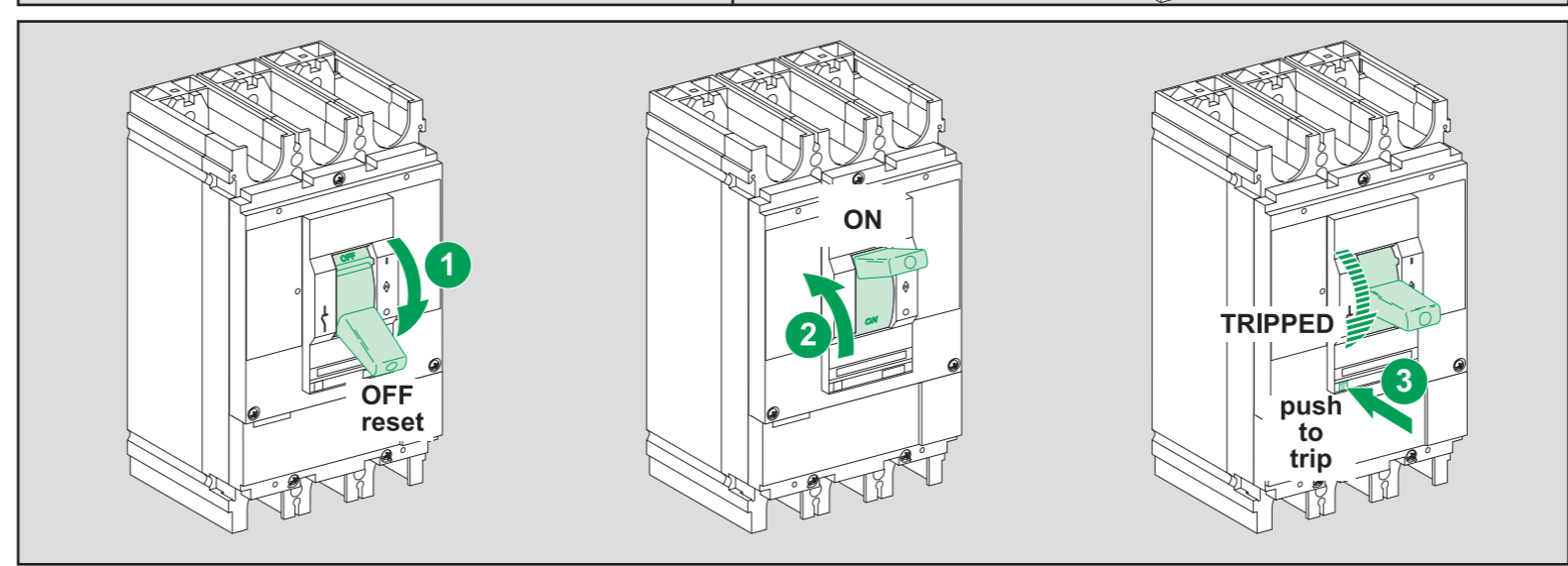
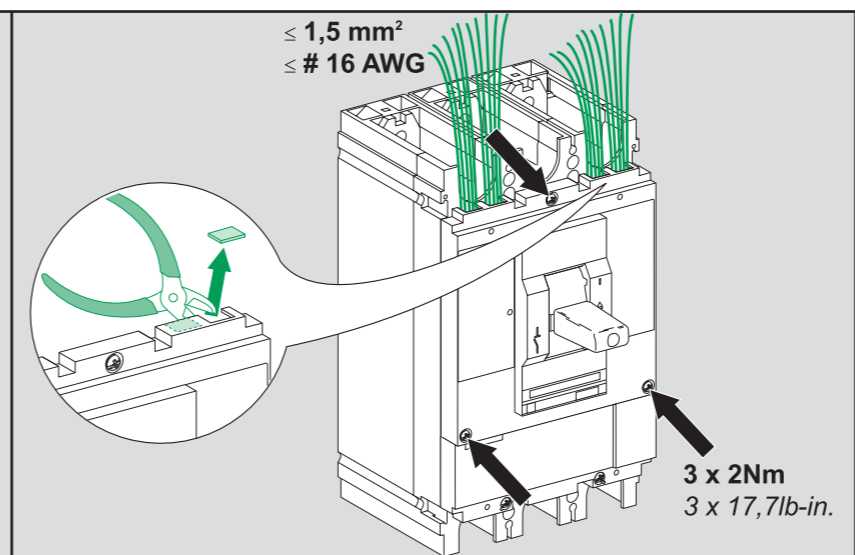
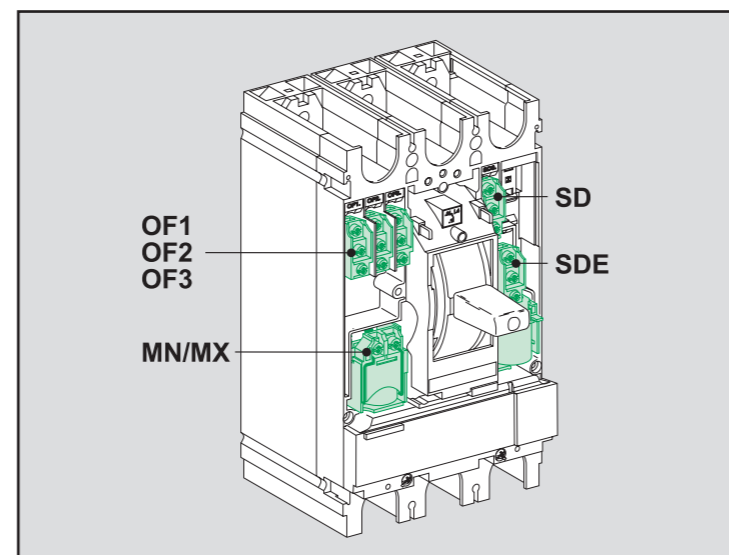
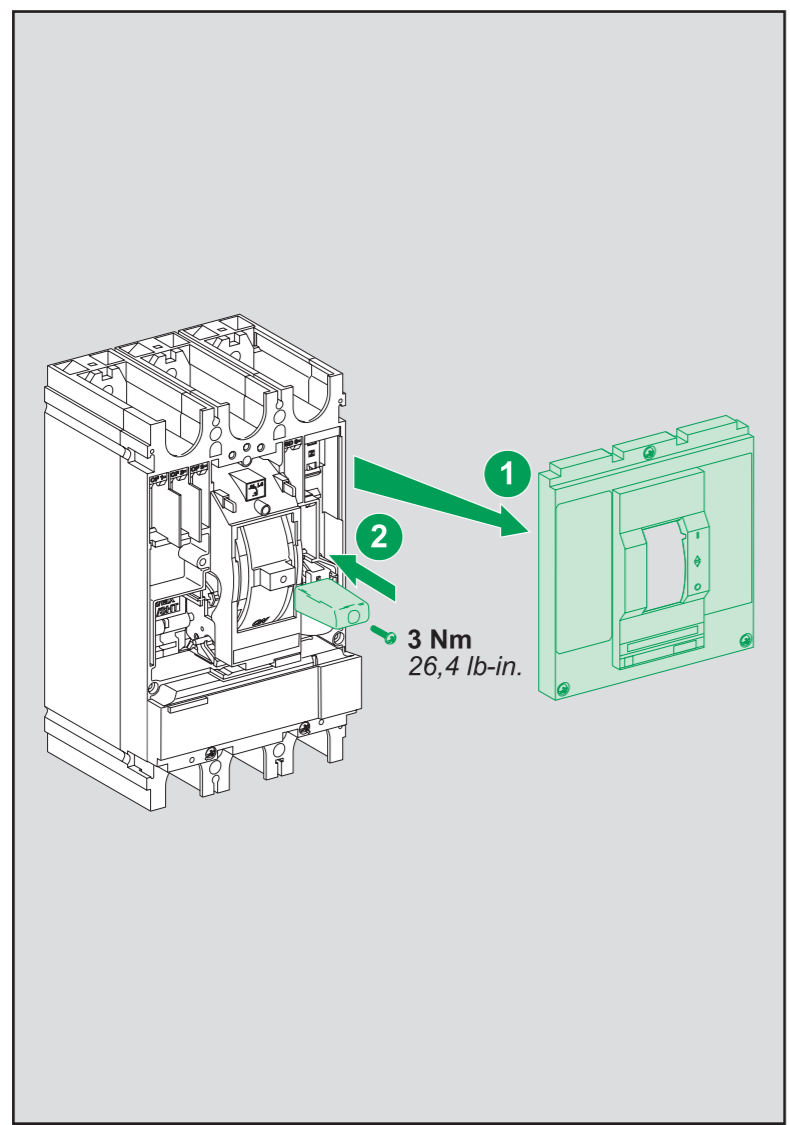
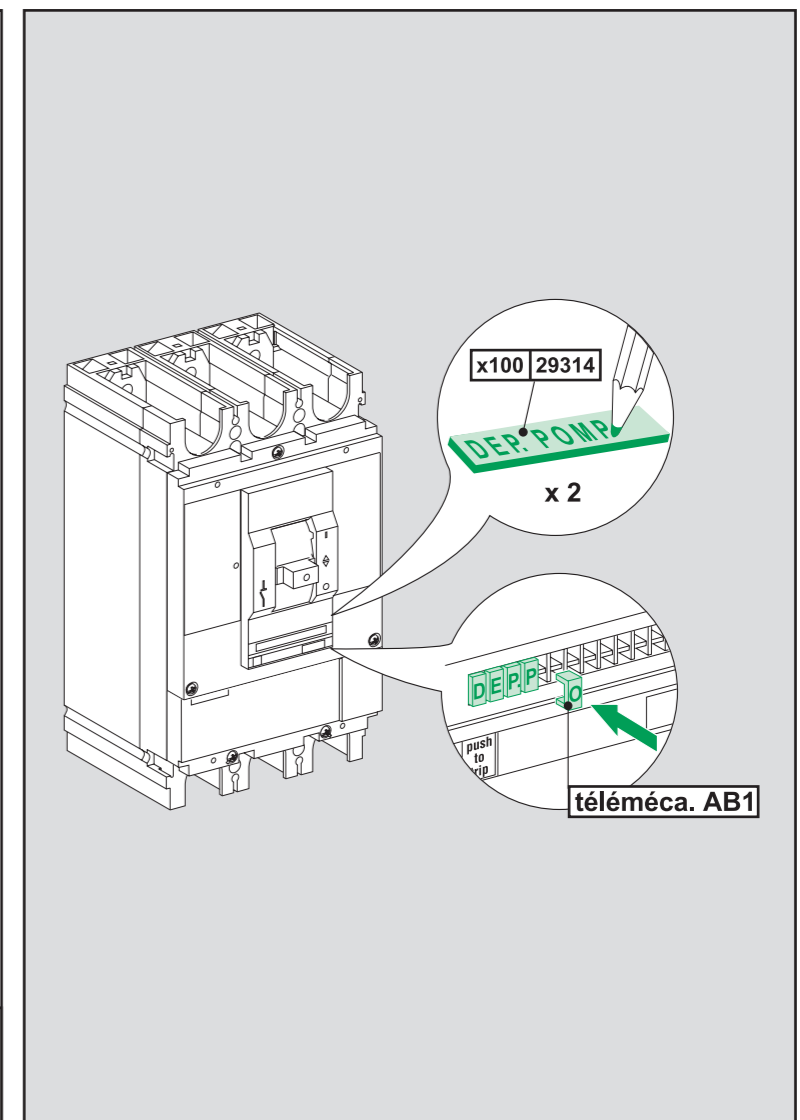



Selection de la longueur de la vis en fonction de la section du câble
 Screw length selection according to the cable cross-section

SECTION DES CABLES CABLES CROSS-SECTION 35 mm ² → 300 mm ² Cu, Al # 2 AWG → 600 kcmil Cu/Al9Cu	mm In.
Couple de serrage Tightening torque 31 Nm 274 lb-in.	
SECTION DES CABLES CABLES CROSS-SECTION 2 x 35 mm ² → 2 x 95 mm ² Cu, Al 2 x # 2 AWG → 2 x 4/0 AWG Cu/Al9Cu	mm In.
Couple de serrage Tightening torque 31 Nm 274 lb-in.	
SECTION DES CABLES CABLES CROSS-SECTION 2 x 120 mm ² → 2 x 240 mm ² Cu, Al 2 x 250 kcmil → 2 x 500 kcmil Cu/Al9Cu	mm In.
Couple de serrage Tightening torque 31 Nm 274 lb-in.	

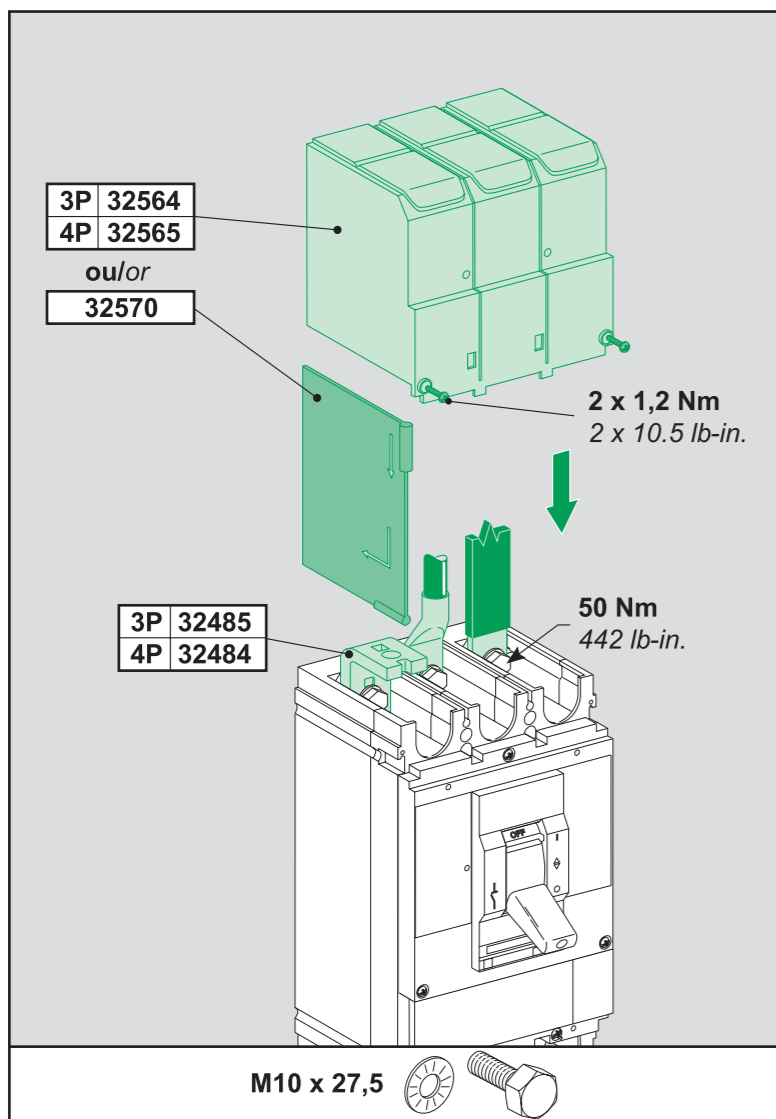
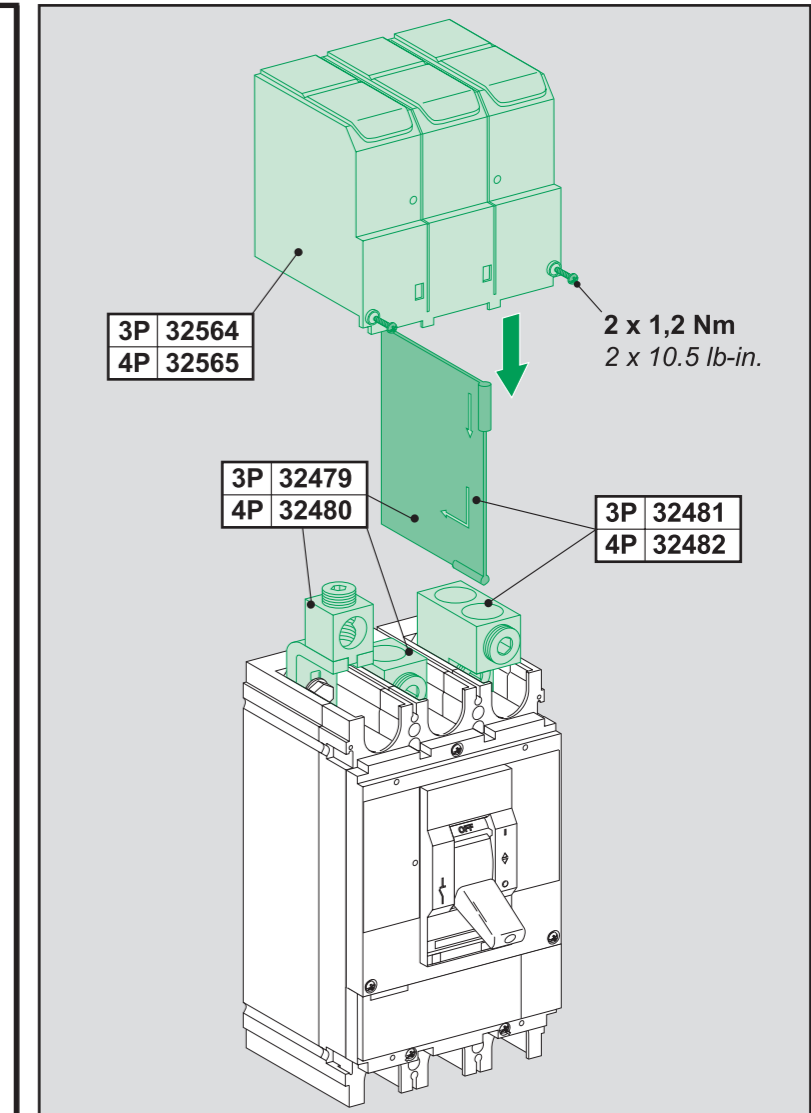
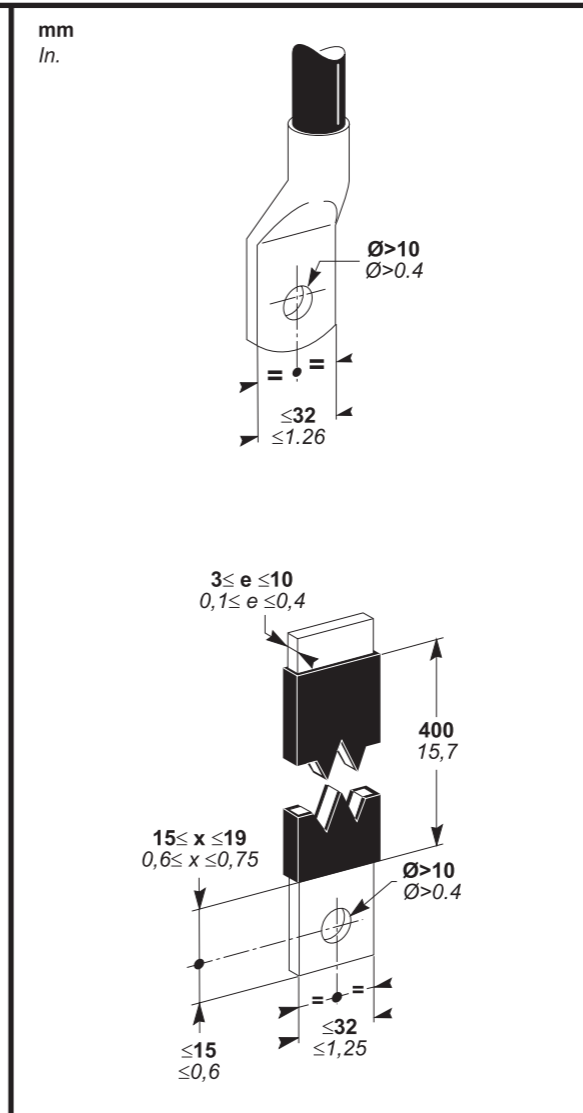
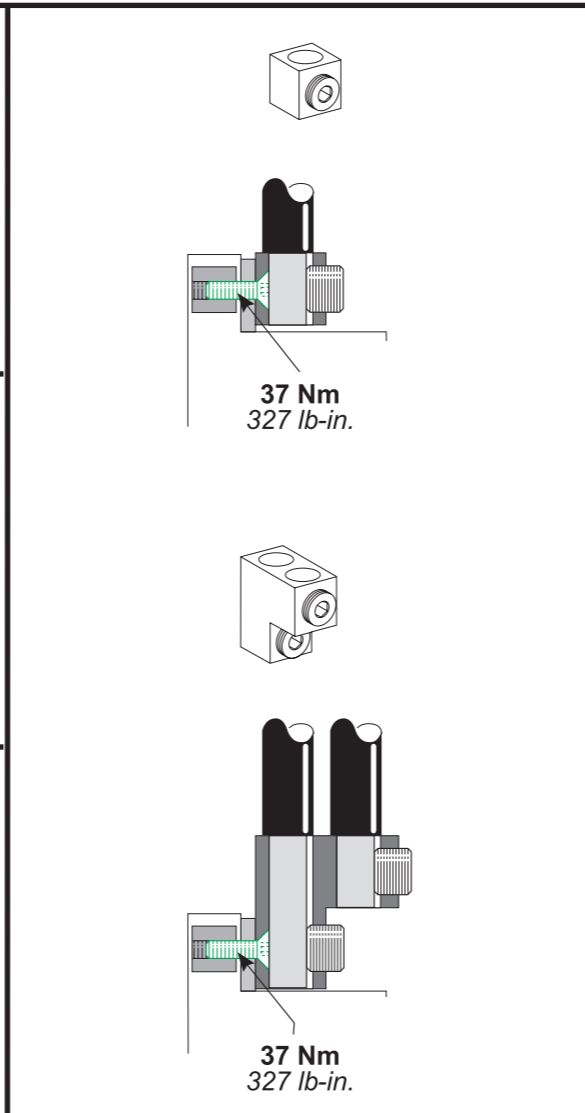
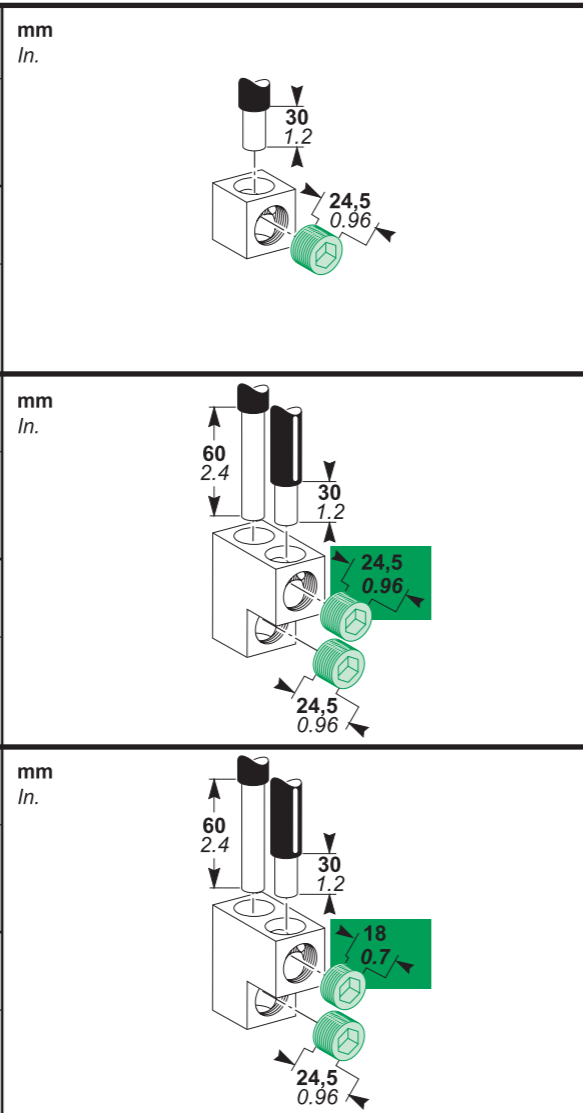

M10 x 27,5

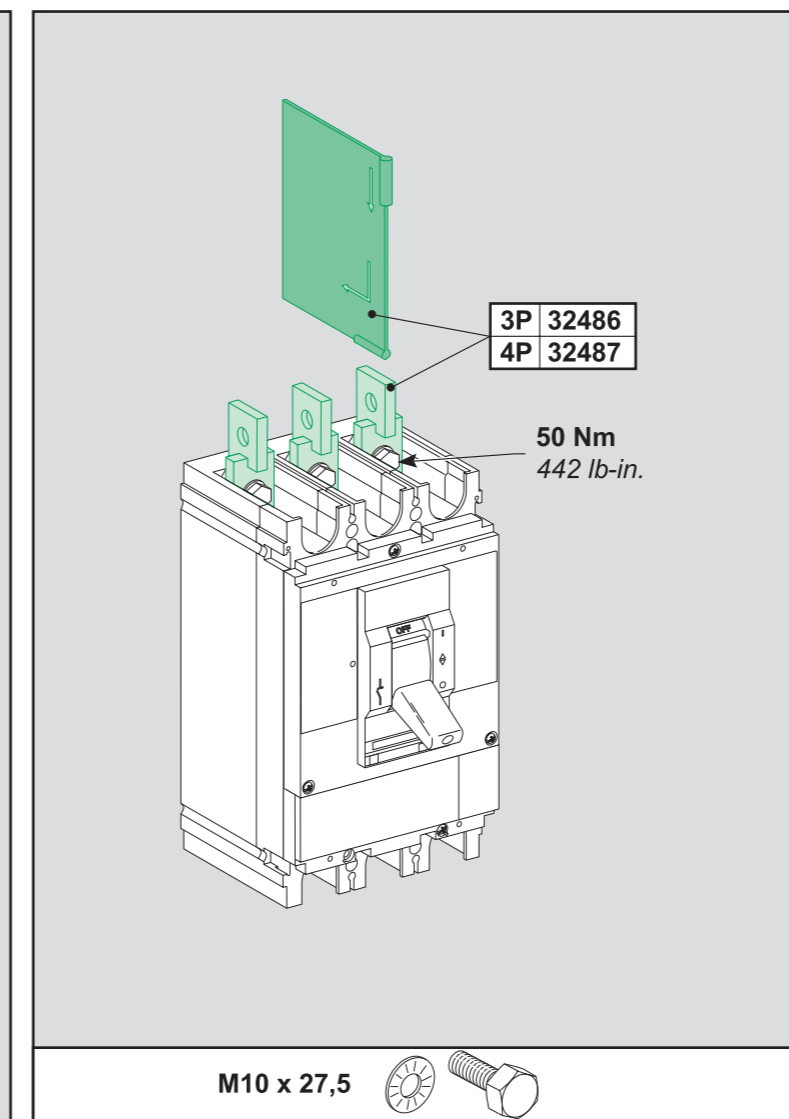
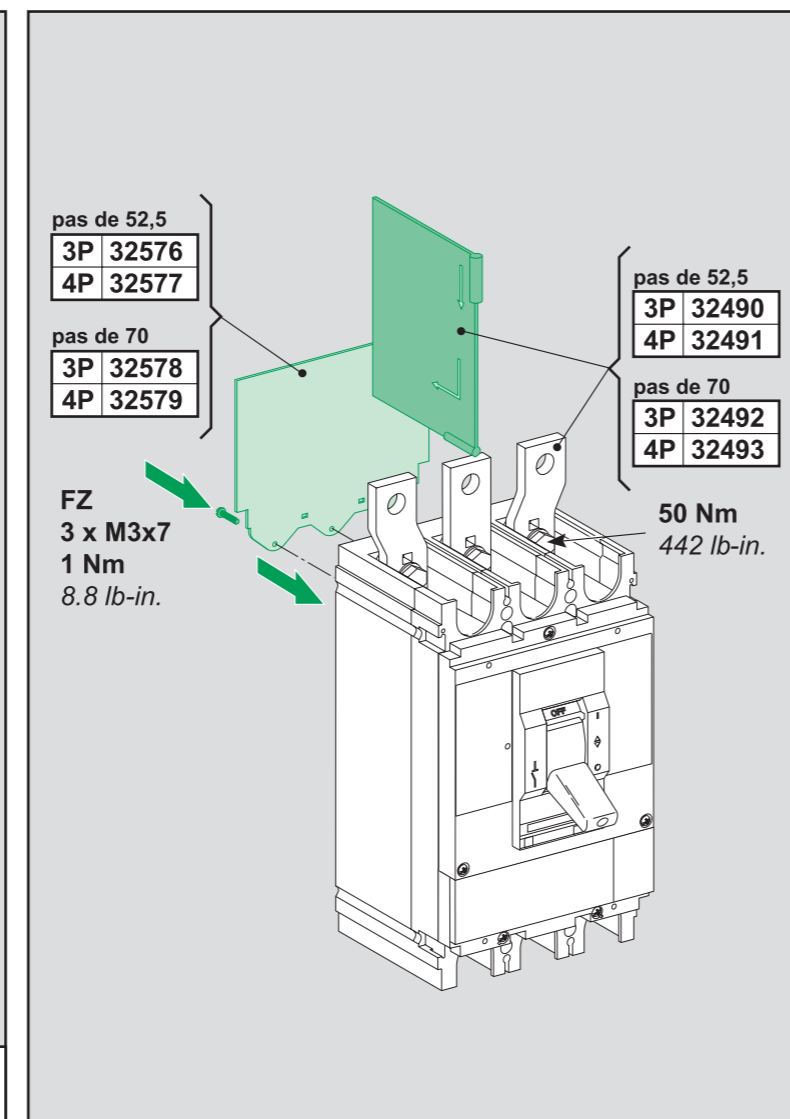

M10 x 27,5

