

# SE8000 Room Controllers

## SE8650 Installation Guide

Roof Top Unit (RTU), Heat Pump and Indoor Air Quality (IAQ)



## TABLE OF CONTENTS

SAFETY INFORMATION .....	3
INSTALLATION .....	6
TERMINAL IDENTIFICATION AND FUNCTION.....	7
REMOTE SENSOR ACCESSORIES .....	7
TYPICAL APPLICATIONS .....	8
HOME SCREEN DISPLAY.....	11
HOW TO ENTER SET-UP SCREEN.....	12
SET-UP SCREEN DISPLAY .....	12
APPENDIX A. TERMINAL CORRESPONDENCE .....	13
APPENDIX B. POWER OUTAGE CLOCK RESET .....	13
APPENDIX C. DEPLOYMENT .....	14

## SAFETY INFORMATION

### Important Information

Read these instructions carefully and look at the equipment to become familiar with the device before trying to install, operate, service or maintain it. The following special messages may appear throughout this bulletin or on the equipment to warn of potential hazards or to call attention to information that clarifies or simplifies a procedure.



The addition of either symbol to a “Danger” or “Warning” safety label indicates that an electrical hazard exists which will result in personal injury if the instructions are not followed.



This is the safety alert symbol. It is used to alert you to potential personal injury hazards. Obey all safety messages that follow this symbol to avoid possible injury or death.

### **DANGER**

**DANGER** indicates a hazardous situation which, if not avoided, **will result in** death or serious injury.

### **WARNING**

**WARNING** indicates a hazardous situation which, if not avoided, **could result in** death or serious injury.

### **CAUTION**

**CAUTION** indicates a hazardous situation which, if not avoided, **could result in** minor or moderate injury.

### **NOTICE**

NOTICE is used to address practices not related to physical injury. The safety alert symbol shall not be used with this signal word.

### Please Note

Electrical equipment should be installed, operated, serviced, and maintained only by qualified personnel. No responsibility is assumed by Schneider Electric for any consequences arising out of the use of this material.

A qualified person is one who has skills and knowledge related to the construction, installation, and operation of electrical equipment and has received safety training to recognize and avoid the hazards involved.

## Before You Begin

### Loss of Control

#### **⚠ WARNING**

##### LOSS OF CONTROL

- The designer of any control scheme must consider the potential failure modes of control paths and, for certain critical control functions, provide a means to achieve a safe state during and after a path failure. Examples of critical control functions are emergency stop and over travel stop.
- Separate or redundant control paths must be provided for critical control functions.
- System control paths may include communication links. Consideration must be given to the implications of anticipated transmission delays or failures of the link.<sup>1</sup>
- Each implementation of equipment utilizing communication links must be individually and thoroughly tested for proper operation before being placed into service.

**Failure to follow these instructions can result in death, serious injury, or equipment damage.**

### California Proposition 65

#### **⚠ WARNING**

##### CALIFORNIA PROPOSITION 65

This product can expose you to chemicals including Lead and Lead compounds, which are known to the State of California to cause cancer and birth defects or other reproductive harm. For more information, go to [www.P65Warnings.ca.gov](http://www.P65Warnings.ca.gov).

**Failure to follow these instructions can result in birth defects or other reproductive harm.**

### Electrostatic Discharge

#### **NOTICE**

##### STATIC SENSITIVE COMPONENTS

Circuit boards and option cards can be damaged by static electricity. Observe the electrostatic precautions below when handling controller circuit boards or testing components.

**Failure to follow these instructions can result in equipment damage.**

Observe the following precautions for handling static-sensitive components:

- Keep static-producing material such as plastic, upholstery, and carpeting out of the immediate work area.
- Store static-sensitive components in protective packaging when they are not installed in the drive.
- When handling a static-sensitive component, wear a conductive wrist strap connected to the component or drive through a minimum of 1 megohm resistance.
- Avoid touching exposed conductors and components leads with skin or clothing.

<sup>1</sup> For additional information about anticipated transmission delays or failures of the link, refer to NEMA ICS 1.1 (latest edition), *Safety Guidelines for the Application, Installation, and Maintenance of Solid State Control* or its equivalent

## Installation

### **NOTICE**

#### **INSTALLATION**

- The system must be installed correctly by a qualified technician.
- If replacing an existing Room Controller, label wires before removal of Controller.
- Electronic controls are static sensitive devices. Discharge yourself correctly before manipulating and installing Room Controller.
- A short circuit or wrong wiring may permanently damage Room Controller or equipment.
- All Room Controllers are designed for use as operating controls only and are not safety devices. Tampering with the devices or unintended application of the devices will result in a void of warranty.
- This device must be installed to provide a separation distance of at least 8in (20cm) from all persons and must not be located or operating in conjunction with any other antenna or transmitter.
- Refer to the Room Controller User Interface Guide for information on how to configure the Room Controller.

**Failure to follow these instructions can result in equipment damage.**

## Location

### **NOTICE**

#### **LOCATION**

- Do not install on an exterior wall.
- Do not install behind a door.
- Do not install in areas with direct heat source.
- Do not install near any air discharge grill.
- Do not install in areas exposed to direct sunlight.
- Ensure Room Controller has sufficient natural air circulation.
- Ensure wall surface is flat and clean.
- Ensure external thermal sensor wirings are away from noisy electrical sources.
- Install 1.3 to 1.5 meter (52 to 60 inches) above the floor.
- Perform preventive maintenance on the damper and Variable Air Volume (VAV) box, according to the supplier documentation.

**Failure to follow these instructions can result in equipment damage.**

## Cleaning the Room Controller

### **NOTICE**

#### **CLEANING THE ROOM CONTROLLER**

- Use a soft, pre-moistened lint-free cloth for cleaning.
- Avoid getting moisture in openings.
- Do not spray anything directly on the Room Controller or use compressed air.
- Do not use caustic/corrosive products, ammonia, solvents or any cleaning product containing alcohol or grit.
- Never use tools directly on the touchscreen.
- Never use paint on the Room Controller.
- Do not drop or crush the Room Controller, or allow it to come into contact with liquids.
- Do not use a damaged device (such as one with a cracked screen).

**Failure to comply with these recommendations will result in damage to the unit and void the manufacturer's warranty.**

## INSTALLATION

1. Remove security screw (if any) on bottom of Room Controller cover.
2. Open unit by pulling on bottom side of Room Controller (Figure 1).
3. Read FCC ID and IC label installed in cover before installing any wireless product.
4. Ensure correct side of base faces up.
5. Pull cables 6in (15cm) out from wall.
6. Align base and mark location of two mounting holes on wall (Figure 2).
7. Install anchors in wall.
8. Insert cable in central hole of base.
9. Insert screws in mounting holes on each side of base.
10. Strip each wire 1/4in (0.6cm) from end.
11. Insert each wire and screw according to wiring chart.
12. Gently push excess wiring back into hole.
13. Gently align cover to top of base and snap in place from bottom (Figure 3).
14. Install security screw.

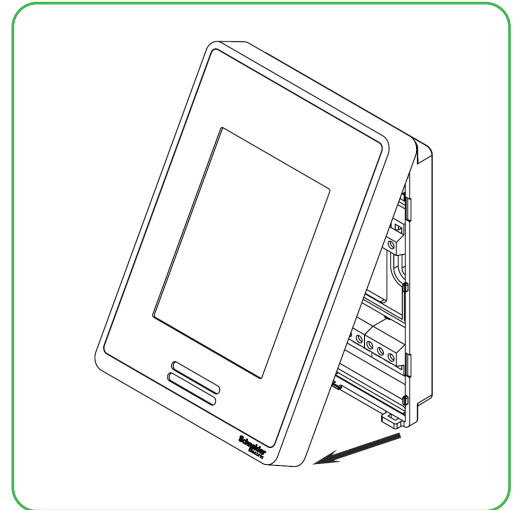

Figure 1 Open cover

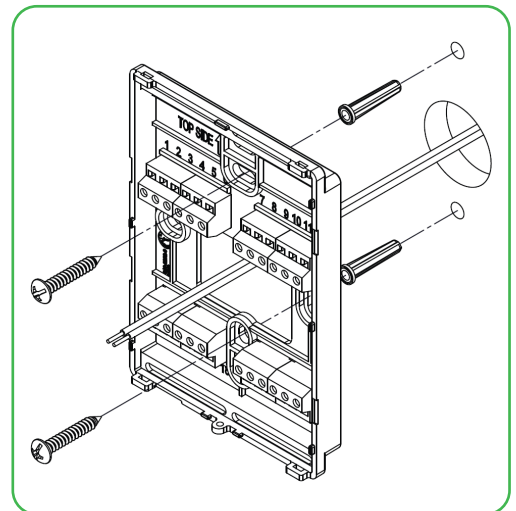

Figure 2 Install base

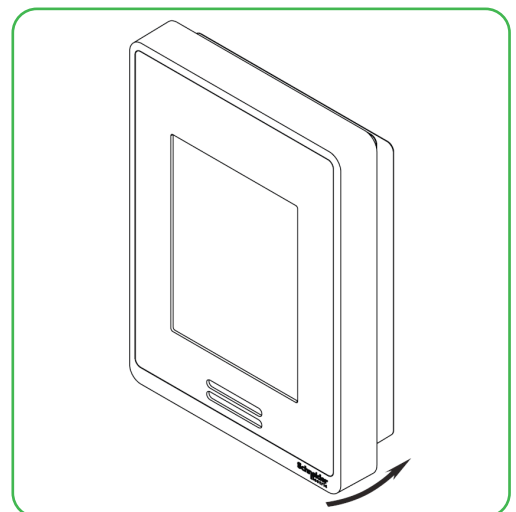

Figure 3 Reinstall cover

## TERMINAL IDENTIFICATION AND FUNCTION

SE8650 Description / Application	Used in applications
	<b>IAQ, HP &amp; RTU</b>
<b>Internal Temperature</b>	<b>X</b>
<b>1- BO1</b>	Aux
<b>2- BO2</b>	Y2
<b>3- BO3</b>	Y1
<b>4- BO4</b>	G
<b>5- RC</b>	RC (24 Vac)
<b>6- C</b>	Common
<b>7- RH</b>	RH
<b>8- BO8</b>	W1
<b>9- UO9</b>	W2 / OB
<b>10- UO10</b>	Econo (0-10 Vdc)
<b>11- UO11</b>	Heat (0-10 Vdc), set "Heat Stages" to 0 to enable
<b>12- UO12</b>	Dehumidification output (24 Vac On/Off)
<b>13- RS485 +</b>	BACnet (+)
<b>14- RS485 -</b>	BACnet (-)
<b>15- RS485 Ref</b>	BACnet Ref. (do not sire shield in this terminal)
<b>16- UI16</b>	UI16 (multifunction input)
<b>17- UI17</b>	UI17 (multifunction input)
<b>18- Scom</b>	Common
<b>19- UI19</b>	CO2 (0-10 Vdc input)
<b>20- UI20</b>	RS (Remote sensor input 10K, type 2 thermistor)
<b>21- Scom</b>	Common
<b>22- UI22</b>	SS (Supply sensor input 10K, type 2 thermistor)
<b>23- UI23</b>	OS (Outside sensor input 10K, type 2 thermistor)
<b>24- UI24</b>	Airflow (0-10 Vdc input)

## REMOTE SENSOR ACCESSORIES

Model no.	Description
S3010W1031	Wall mounted temperature sensor
S3020W1031	Wall mounted temperature sensor with override button and occupancy status LED

### NOTE:

If one or multiple sensor(s) is/are connected into the RS terminal, the internal temperature sensor is automatically disabled. Disconnecting the sensor(s) in RS terminal will re-activate the internal sensor.

Remote mount temperature sensors inputs use 10K type 2 NTC thermistors.

### Features:

- Each sensor can be configured for various averaging combinations. Refer to S3000 series remote sensors for more details.

### Temperature vs. resistance chart for 10 Kohm NTC thermistor (R25°C = 10KΩ±3%, B25/85°C = 3975K±1.5%)

°C	°F	Kohm	°C	°F	Kohm	°C	°F	Kohm	°C	°F	Kohm	°C	°F	Kohm
-40	-40	324.3197	-20	-4	94.5149	0	32	32.1910	20	68	12.4601	40	104	5.3467
-35	-31	234.4009	-15	5	71.2430	5	41	25.1119	25	77	10.0000	45	113	4.3881
-30	-22	171.3474	-10	14	54.1988	10	50	19.7390	30	86	8.0694	50	122	3.6202
-25	-13	126.6109	-5	23	41.5956	15	59	15.6286	35	95	6.5499	55	131	3.0016

### TYPICAL APPLICATIONS

#### RTU: 2 HEATING / 2 COOLING

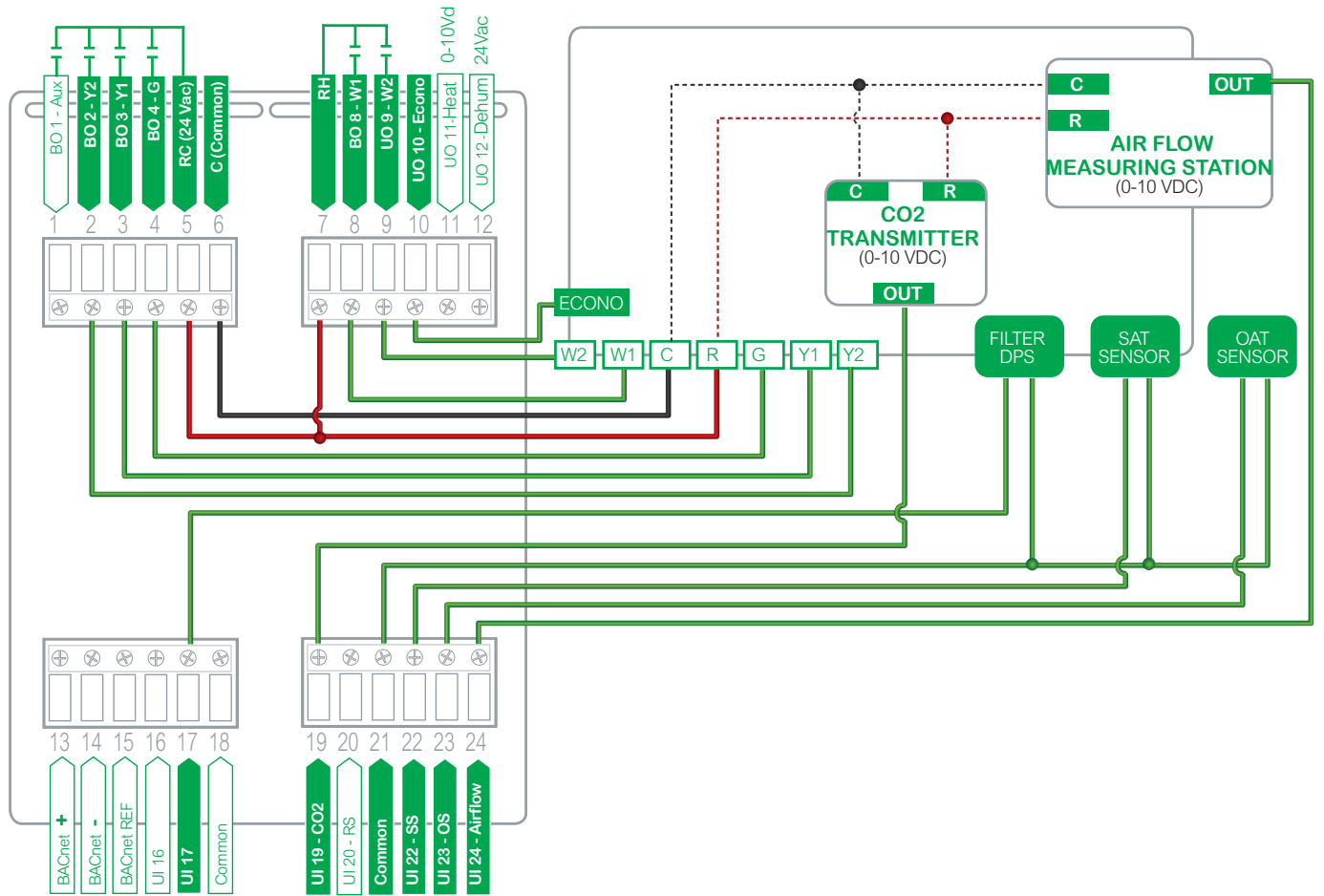



**RTU: 2 COOLING / MODULATING HEAT**

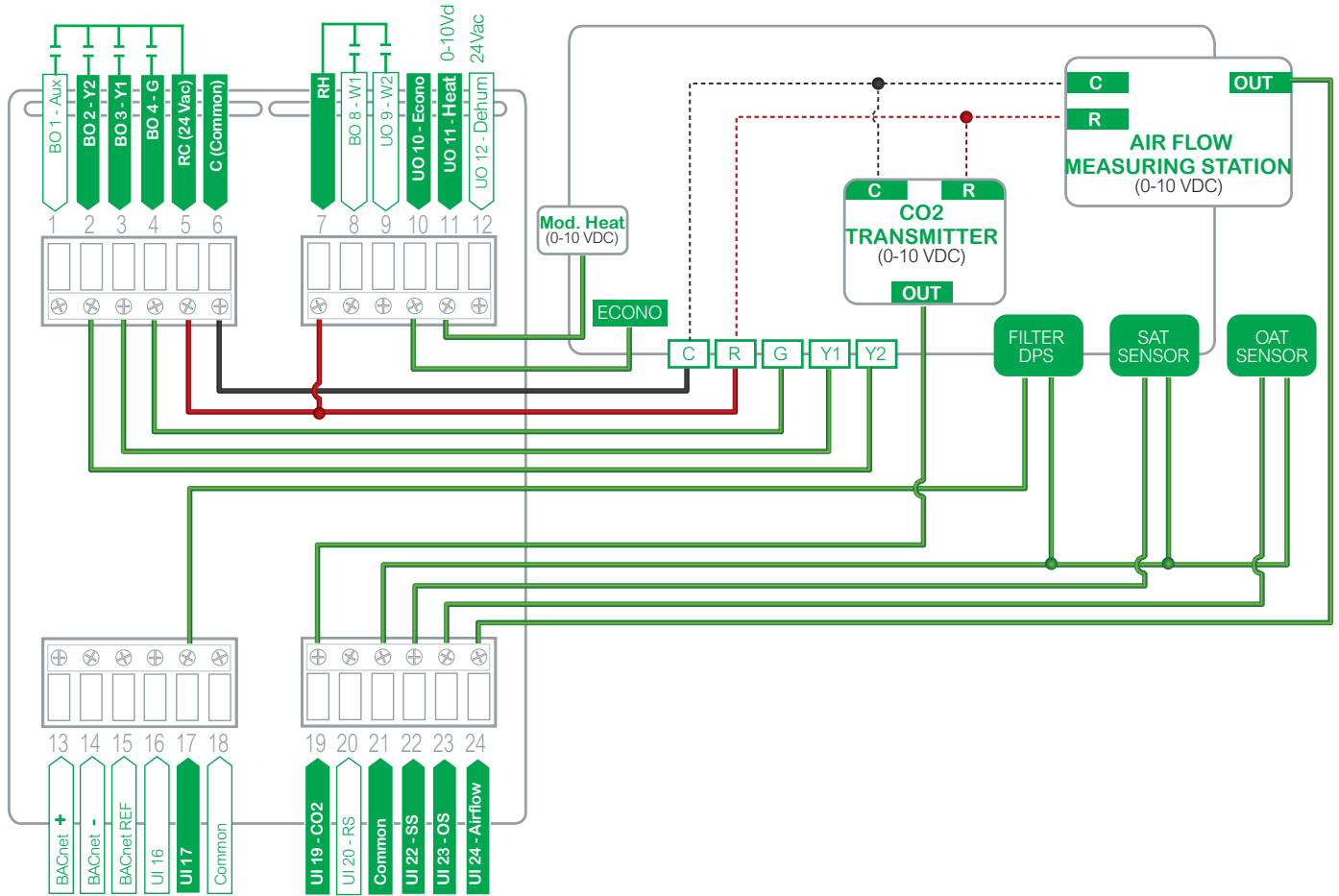

## 2 COMPRESSORS, AUXILIARY HEAT AND ECONOMIZER

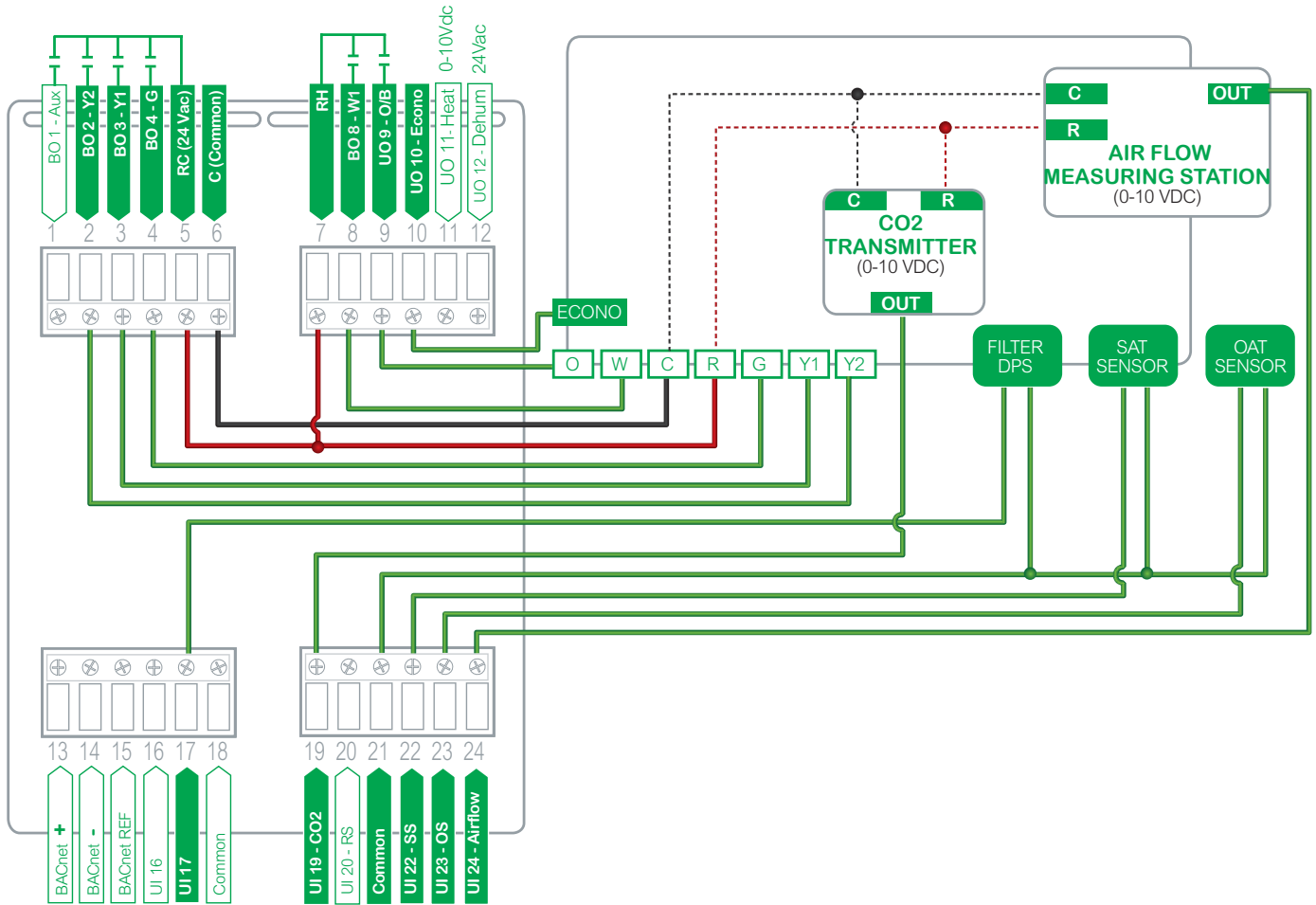

## HOME SCREEN DISPLAY

Typical Hospitality User Interface Shown

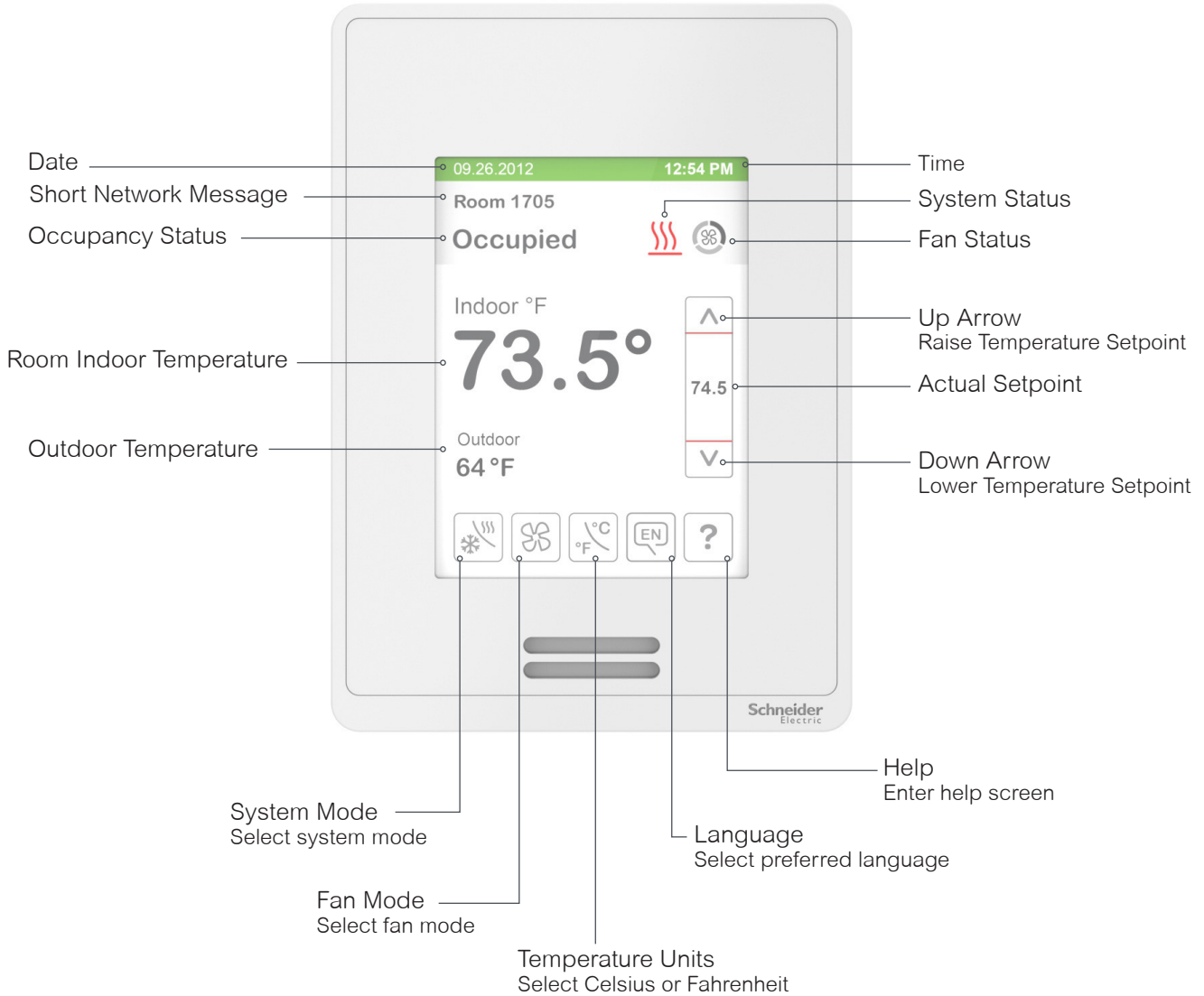

**NOTE:** User HMI is configurable and allows display functions such as Outdoor Temperature, Setpoint, and other buttons to be enabled or disabled by setting various parameters in the setup screens.

### HOW TO ENTER SET-UP SCREEN

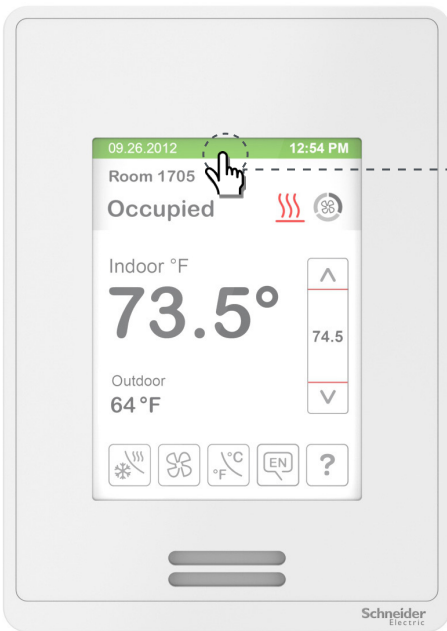

Touch and hold this point for 3 seconds to enter set-up mode

For more information on using and configuring the functions of the HMI, refer to **SE8650 User Interface Guide**

**NOTE:** If a configuration/installer password is activated to prevent unauthorised access to the configuration menu parameters, a password entry prompt shows to prevent access to device configuration components.

### SET-UP SCREEN DISPLAY

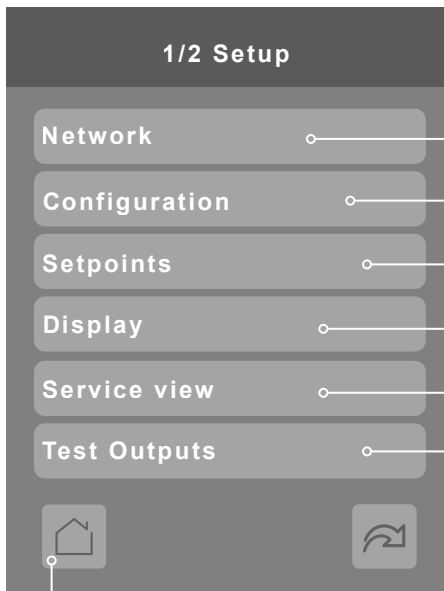

Enter BACnet® & ZigBee® network settings

Enter parameter configuration menu

Enter setpoint settings

Enter display settings

Enter status display (read only)

Enter test outputs settings

Return to home screen

General Note:

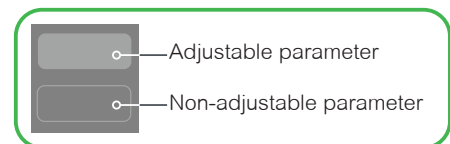

## APPENDIX A. TERMINAL CORRESPONDENCE

The terminals of a SE8650 are identified differently and have a wider range of possible functions compared to those of any of the SE7000 Room Controllers. Nonetheless, there is a direct correspondence of functions between the terminals of the SE7000 and the SE8650. Consult the table below to verify the appropriate terminal when replacing a SE7000 Room Controller with a SE8650 Room Controller.

SE7000		SE8650	
Terminal name	Terminal ID	Terminal name	Terminal ID
Binary Input 1	BI1	Universal Input 16	UI16
Binary Input 2	BI2	Universal Input 17	UI17
Universal Input 3	UI3	Universal Input 19	UI19
Sensor Common	Scom	Terminal 18 Common	COM
Remote Sensor	RS	Universal Input 20	UI20 - RS
Sensor Common	Scom	Terminal 21 Common	COM
Mix/Supply Sensor	MS	Universal Input 22	UI22 - SS

## APPENDIX B. POWER OUTAGE CLOCK RESET

In the event of a power outage, Room Controllers retain the correct time as long as the duration of the power outage is not prolonged. Depending on the duration of the power outage, the Room Controllers internal clock may need to be updated or reset completely. The following table gives an indication of the expected clock performance after a power outage of a given duration.

Outage duration	Room Controller behavior
0 - 24 hours	Clock functions are normal
24 - 36 hours	Clock accuracy not guaranteed, time may need to be adjusted
36 - 72 hours	Clock no longer increments and must be adjusted when power is restored.
72+ hours	Clock functions are fully reset, and must be reinitialized as per a new installation.

## APPENDIX C. DEPLOYMENT

Placement of the Room Controller must be given consideration. It is recommended to install the Room Controller as close to a door as possible (but not so as to be blocked by the door), or in an area with high occupant movement.

Ideally the Room Controller should be installed 5 feet (1.5 meters) above the floor surface to ensure maximum detection range is achieved. As well, Room Controller placement should ensure the occupant crosses the lens beam in a perpendicular path within the prescribed detection zone.

### C.1 EXAMPLE OF RECOMMENDED DEPLOYMENT

The below shows Room Controllers installed in ideal locations for two rooms.

The examination room shows one Room Controller installed adjacent to the door. In this area of the room, occupant traffic is high and ensures the occupant will almost always cross the PIR detection path laterally and within the detection range.

The waiting room shows one Room Controller installed beside a door in the middle of the room. As shown in the diagram below, occupant traffic is high in several areas of the room including the entrance, waiting room, access to the door and activity around the reception desk. Moreover, for each case aforementioned, occupant movement almost always moves lateral to the PIR, which ensures detection by the PIR, as well as respecting the PIR detection range of 20 feet (6 meters) at 140°, and 16 feet (5 meters) between 15° to 30° laterally.

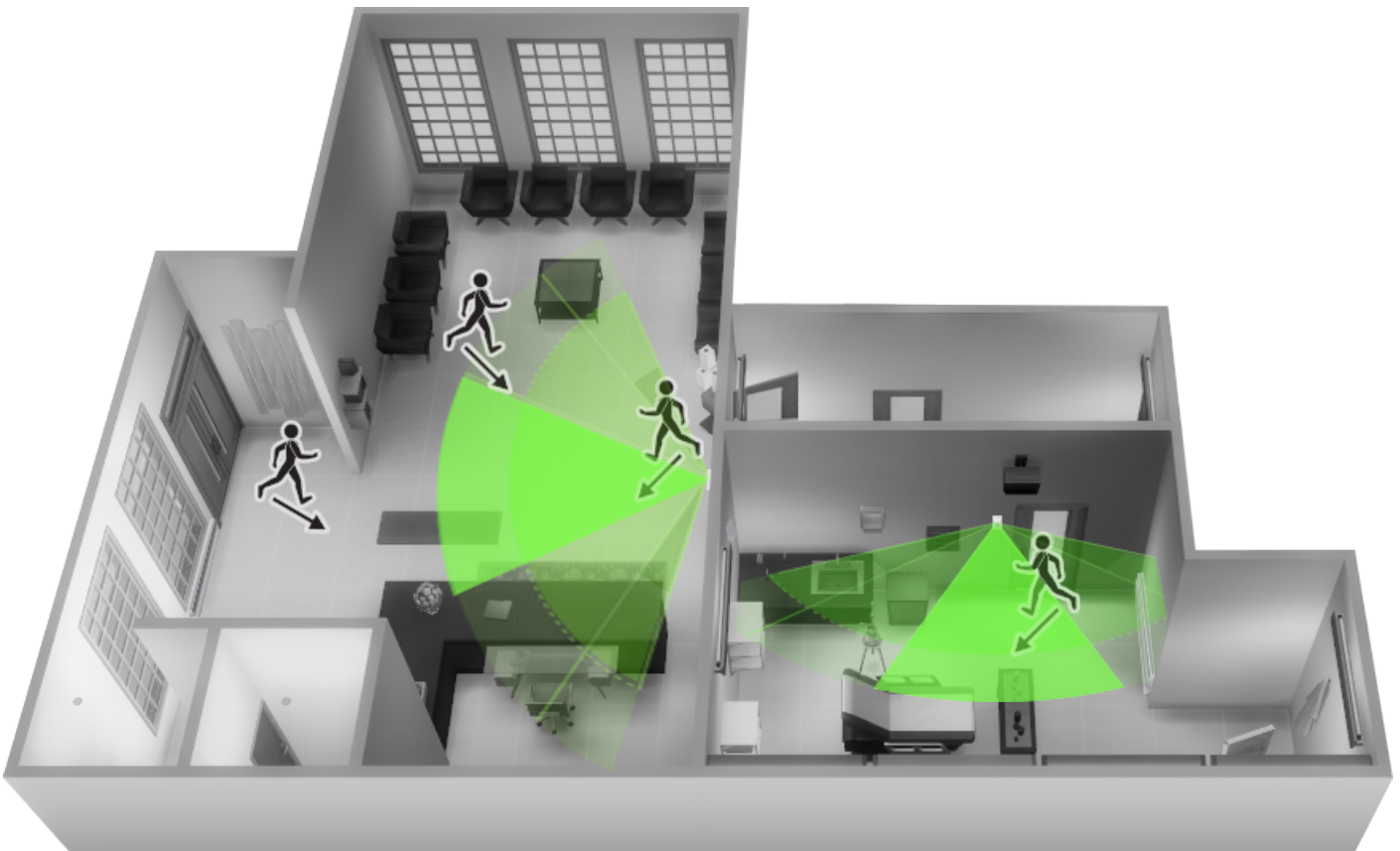

Recommended Installation

## C.2 EXAMPLE OF NON-RECOMMENDED DEPLOYMENT

The below shows four Room Controllers (two for each room) installed in non-ideal locations for the two rooms.

The examination room shows one Room Controller installed in a low traffic area near the door, and a second Room Controller installed on the wall directly opposite the door. For the Room Controller installed in the corner wall, the PIR could be blocked by the opened door, while occupant traffic could also be minimal in this area of the room. For the second Room Controller installed opposite the door, the PIR detection could fall outside the specified detection zone, while at the same time most occupant movement would be not be lateral to the PIR, thereby not respecting optimal crossing patterns for PIR detection.

The waiting room shows one Room Controller installed in the corner of the room, and a second Room Controller installed beside the reception area. For the Room Controller installed in the corner, the opening/closing of the door creates high probability that the PIR would get blocked, and therefore, occupancy going undetected. For the Room Controller installed beside the reception area, occupant traffic could fall outside the detection zone, and the receptionist would often be below the 5 foot recommended installation height for the Room Controller.

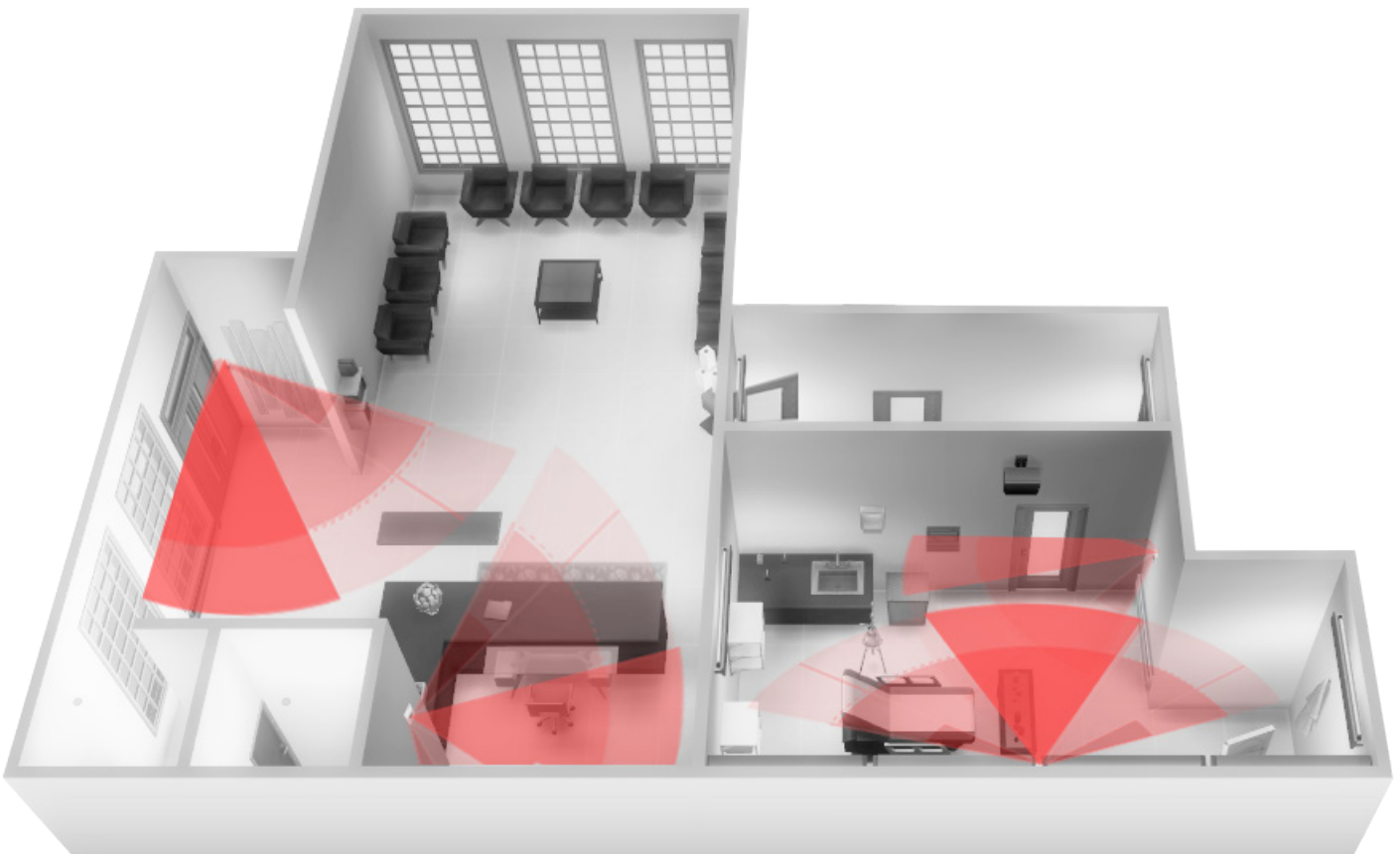

Non-Recommended Installation

### C.3 ROOM CONTROLLER PIR SENSOR DETAILS

The internal Room Controller PIR sensor only detect lateral movement. It cannot detect movement when a person is moving toward it. It will not detect someone seating on a chair and/or lying on the bed.

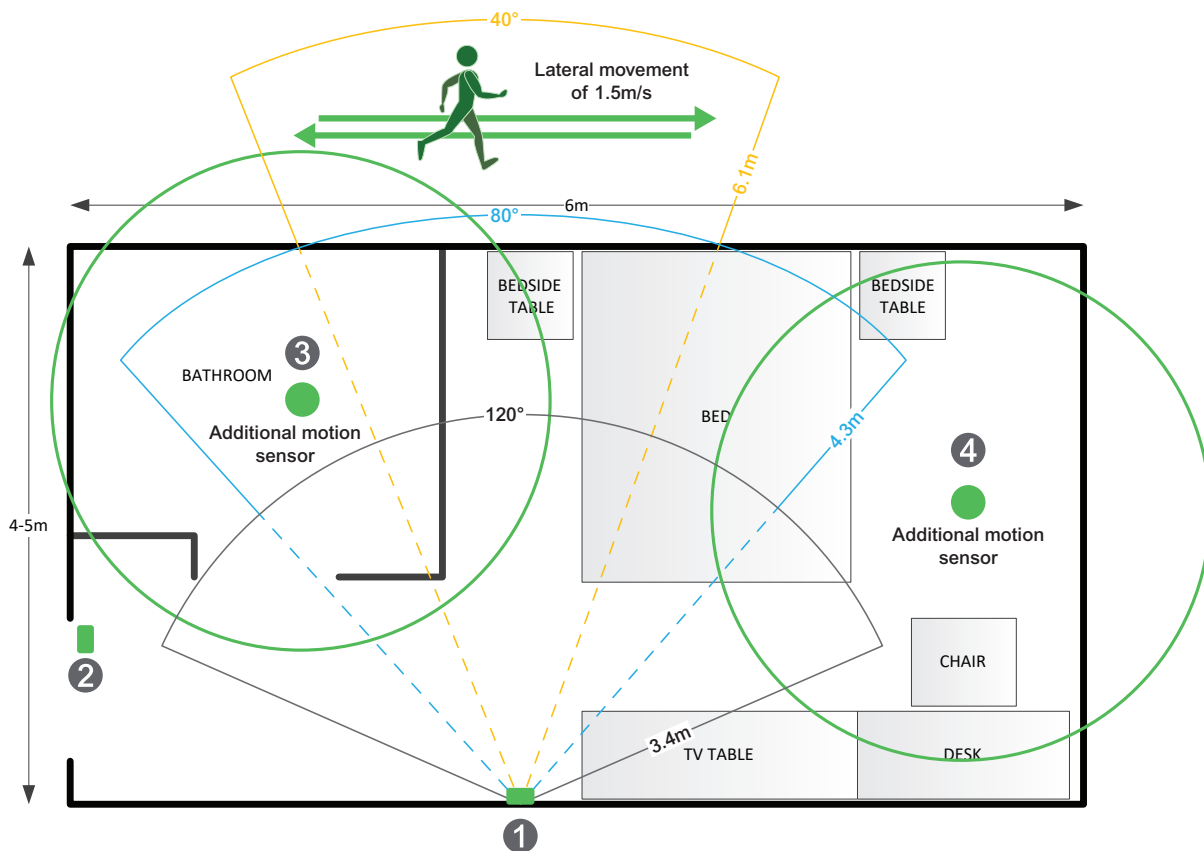

### C.4 RECOMMENDATIONS FOR INSTALLATIONS

1. Install the Room Controller to cover more lateral movement.
2. Install a door sensor, the internal Room Controller occupancy logic works better with a door sensor. Once a motion is detected after a door is opened, the room stays in occupied state until the door is opened again which put the Room Controller in stand-by mode and if there is a motion then it goes back in occupied mode. It is also recommended to disable the unoccupied mode, set the unoccupied time to 0, so there is only 2 modes in the Room Controller: stand-by and occupied for a stand-alone solution. Please refer to the two(2) diagrams below for the Room Controller internal occupancy states transition.

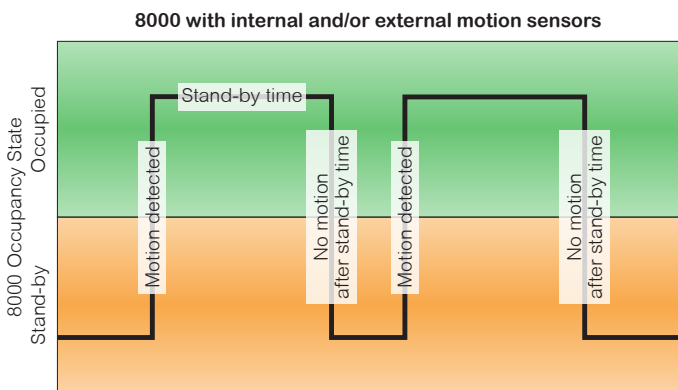

More aggressive energy savings logic but may cause bad guest experience (when guest is sleeping or not moving)

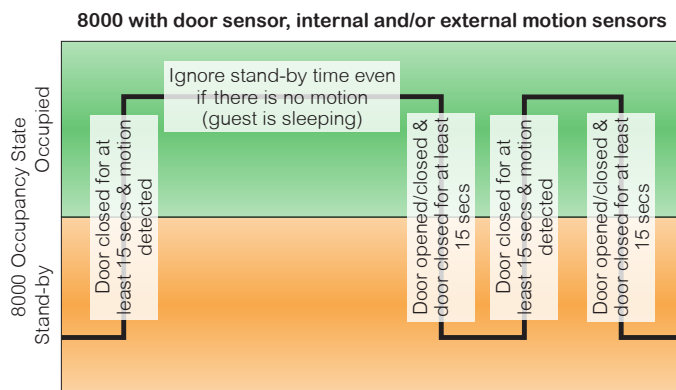

Good energy savings logic and better guest experience even when the guest is sleeping or not moving

3. Install additional motion sensor in the bathroom.
4. Install additional motion sensor for better motion detection in the entire room.



### C.5 ENERGY SAVINGS

PIR can maximize your energy saving from 10-30% by adjusting temperature set points in unoccupied zones during scheduled periods.

PIR can maximize your energy saving from 10-30% by adjusting temperature set points in unoccupied zones during scheduled periods.

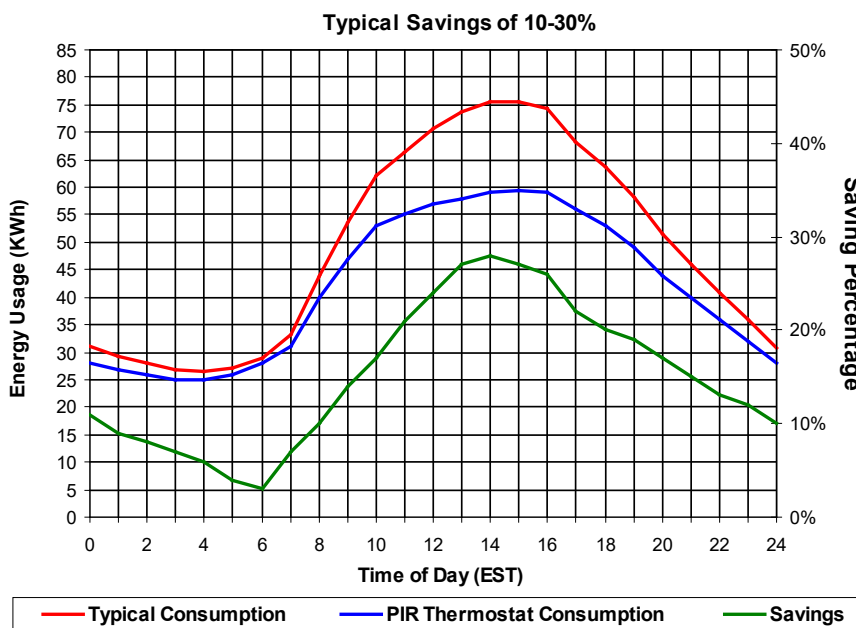

# Technical Support



For any issues with SmartStruxure Solution or SmartStruxure Lite, contact Schneider Electric Technical Support according to your region.

North America (NAM) Product Support  
Building Management Systems (BMS): [www.nampss.com](http://www.nampss.com)

Global Product Support  
Building Management Systems (BMS): [productsupport.BMS@schneider-electric.com](mailto:productsupport.BMS@schneider-electric.com)

Schneider Electric  
CS 30323  
F-92506 Rueil-Malmaison Cedex  
France

Schneider Electric is leading the Digital Transformation of Energy Management and Automation in Homes, Buildings, Data Centers, Infrastructure and Industries.

With global presence in over 100 countries, Schneider is the undisputable leader in Power Management – Medium Voltage, Low Voltage and Secure Power, and in Automation Systems. We provide integrated efficiency solutions, combining energy, automation and software.

In our global Ecosystem, we collaborate with the largest Partner, Integrator and Developer Community on our Open Platform to deliver real-time control and operational efficiency.

We believe that great people and partners make Schneider a great company and that our commitment to Innovation, Diversity and Sustainability ensures that Life Is On everywhere, for everyone and at every moment.

[www.schneider-electric.com](http://www.schneider-electric.com)