

Uniflair™ SP

UCF0341I, UCF0481I, MRA0221I, MRA0661D

Technical Specifications

990-91231A-001

Release Date: 05/2019



Legal Information

The Schneider Electric brand and any trademarks of Schneider Electric SE and its subsidiaries referred to in this guide are the property of Schneider Electric SE or its subsidiaries. All other brands may be trademarks of their respective owners.

This guide and its content are protected under applicable copyright laws and furnished for informational use only. No part of this guide may be reproduced or transmitted in any form or by any means (electronic, mechanical, photocopying, recording, or otherwise), for any purpose, without the prior written permission of Schneider Electric.

Schneider Electric does not grant any right or license for commercial use of the guide or its content, except for a non-exclusive and personal license to consult it on an "as is" basis. Schneider Electric products and equipment should be installed, operated, serviced, and maintained only by qualified personnel.

As standards, specifications, and designs change from time to time, information contained in this guide may be subject to change without notice.

To the extent permitted by applicable law, no responsibility or liability is assumed by Schneider Electric and its subsidiaries for any errors or omissions in the informational content of this material or consequences arising out of or resulting from the use of the information contained herein.

Table of Contents

Technical Data	5
Model Nomenclature	5
Indoor Units	5
Outdoor Units	5
Overview	6
General Description	6
Features	6
Compliance	8
Equipment Guidelines	9
Working Conditions and Environmental Limits	9
Free-Cooling Cycle	10
UCF Models	10
Component Identification	11
External Components	11
Indoor Units	11
Outdoor Units	12
Internal Components	14
Indoor Units	14
Outdoor Units	16
Electrical Panels	18
Indoor Units	18
Outdoor Units	18
Display Interface	20
Alarm LED	20
Status LED	21
Link-RX/TX (10/100) LED	21
Performance Specifications	22
Cooling Capacity	22
Electrical Data	26
Indoor Units	26
Outdoor Units	27
Dimensions and Weights	28
Indoor Units	28
Outdoor Units	29

Technical Data

Model Nomenclature

Indoor Units

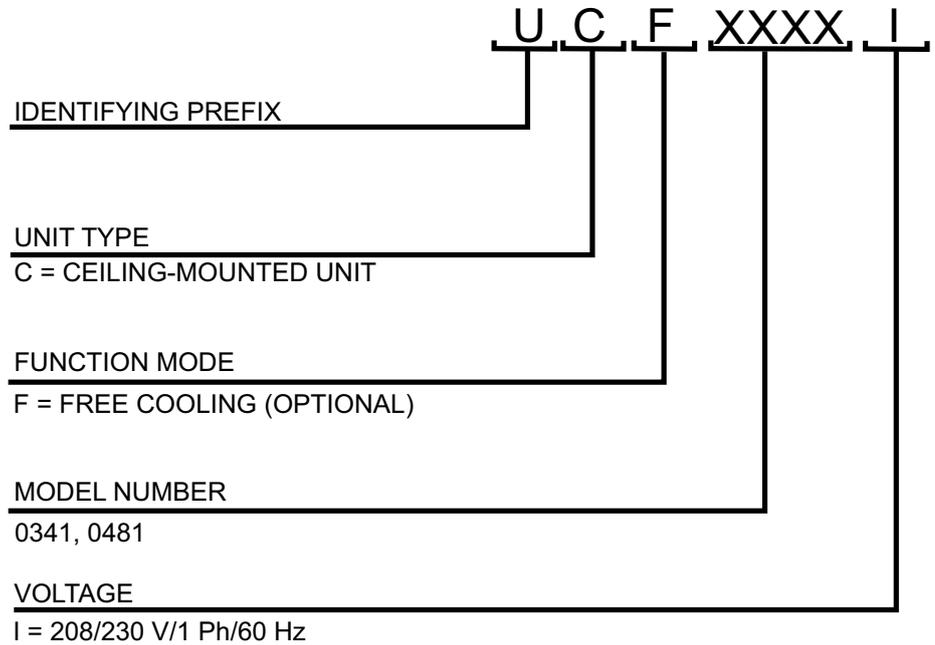

Outdoor Units

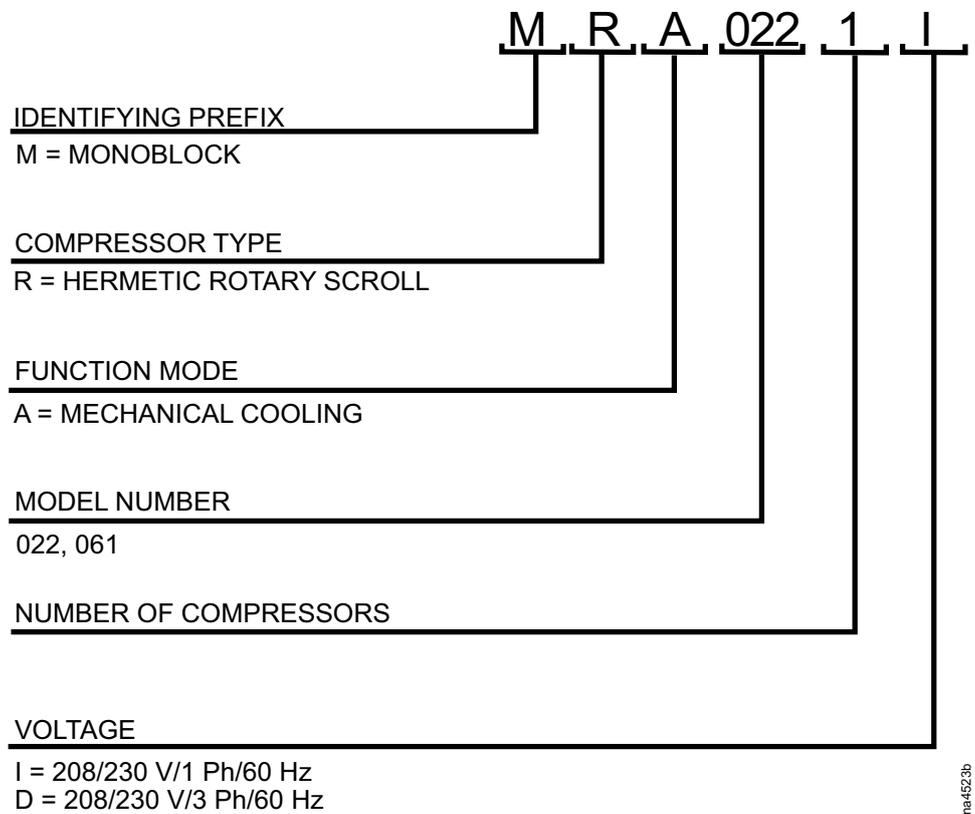

Overview

General Description

Uniflair SP direct-expansion air conditioning units with air-cooled condensing units are designed for Telecom, ITE, and computer room/DC applications. Uniflair SP units have two separate sections: the evaporating section (UCF) in the room to be air conditioned and the condensing section (MRA), that is installed externally. The evaporating section is installed on the ceiling and enables management of room parameters through a sophisticated microprocessor controller. The UCF model can be accessorized to include an optional intelligent free-cooling system that allows the free-cooling of the room even with high external temperatures. The UCF units are intended for ceiling mount, horizontal flow applications with a free air discharge.

Features

Evaporating Unit (Indoor Unit)

Feature	Description
Self-supporting frame	Self-supporting frame in galvanized steel with panels finished in epoxy powders (color RAL9003). The paint, which conforms to the ASTM B117 standards, provides resistance to saline humidity, allowing units to be installed in the most testing atmospheric conditions.
Filter	Filter is EU2 efficiency equipped in a rigid frame. The air filter rating is MERV4.
Refrigerant circuit	Refrigerant circuit includes filter drier, liquid sight glass, thermostatic expansion valve, and refrigerant shut-off valves.
Cooling coil	Cooling coil has a large frontal area, is made out of copper tubing mechanically expanded into aluminum fins, and has a stainless steel condensate drain tray with flexible tube.
Air distribution plenum	Air distribution plenum is complete with delivery grille with double row of slats.
Airflow sensor	Airflow sensor activates an Insufficient Airflow alarm.
Free-cooling damper (optional)	Free-cooling damper for introduction of external air and free-cooling of the room.

Condensing Unit (Outdoor Unit)

Feature	Description
Self-supporting frame	Self-supporting frame in galvanized steel with panels finished in epoxy powders (color RAL9003). The paint, which conforms to the ASTM B117 standards, provides resistance to saline humidity, allowing units to be installed in the most testing atmospheric conditions.
Hermetic-scroll compressors	Equipped with hermetic-scroll compressors with high efficiency and internal thermal protection.
Refrigerant circuit	Refrigerant circuit includes filter dryer, liquid sight glass, thermostatic expansion valve, and refrigerant shut-off valves.

Feature	Description
Variable speed condenser fan	Condenser fan speed varies in relation to condensation pressure.
High-pressure pressostat transducer	Transducer for reading of condensation pressure.
Fans	Axial fans, statically and dynamically balanced on two planes, with non-rusting blades, external rotor motor suitable for variable speed control, mounting on a metal support frame, and which conforms to safety norms.

Compliance

These units are intended for installation in a non-public location with restricted access, and with installation, use, and maintenance performed by professionally trained personnel.

The manufacturer declares that this product is compliant with the following standards:

- UL 1995
- CSA 22.2 No. 236-11
- FCC Part 15 Subpart B
- CSA ICES-003 Issue 5

The appliance operates safely in the areas of application for which it was intended, provided its installation, commissioning, and maintenance are performed in compliance with the documentation for the unit and with the labels affixed to the unit.

It is necessary to install a supply disconnect on the fixed wiring located near the unit to provide the safety shutdown and disconnection of the power supply. Follow local and national codes and regulations.

The installed mains power disconnect must do the following:

- Isolate the electrical equipment from the supply and have one OFF and one ON position.
- Be provided with a means for locking the device in the OFF (isolated) position with Lockout Tagout
- Have a breaking capacity sufficient to interrupt the rated current (see rated parameter on the unit nameplate or Technical Specifications)
- Be easily accessible and located between 0.6 m (2 ft) and 1.9 m (6 ft) above where the service personnel stands to service the unit

After unit installation, it is necessary to evaluate the fault-loop impedance and automatic protection coordination.

Equipment Guidelines

Working Conditions and Environmental Limits

Limit Working Conditions	
Power supply	208 V, 1 Ph, 60 Hz 230 V, 1 Ph, 60 Hz
Voltage input tolerance	±10%*
Voltage imbalance	Maximum 3% for 3-phase units
Frequency input tolerance—continuously	±0.5 Hz
Frequency input tolerance—short time	±1 Hz
Maximum altitude	2000 m (6562 ft)
Room Conditions	
Temperature	18°C to 40°C (64.4°F to 104°F)
Humidity	Relative humidity: 30 to 70%RH
DX Operational Conditions	
Temperature	-23°C to 46°C (-10°F to 115°F)
Storage Temperature	
Temperature	-23°C to 50°C (-10°F to 122°F)

*MRA0221I is only -5%/+10%

Unit	Assembly	Power Supply
UCF0341I	Indoor	208 V, 1 Ph, 60Hz 230 V, 1 Ph, 60Hz
UCF0481I		208 V, 1 Ph, 60Hz 230 V, 1 Ph, 60Hz
MRA0221I	Outdoor	208 V, 1 Ph, 60Hz 230 V, 1 Ph, 60Hz
MRA0611D		208 V, 3 Ph, 60Hz 230 V, 3 Ph, 60Hz

Free-Cooling Cycle

UCF Models

The free-cooling cycle consists of the introduction of outdoor air into the room when the outdoor air is sufficiently cool to absorb the thermal load of the room. The unit is equipped with a butterfly damper and two air intakes:

- Recycled air intake
- Outdoor air intake

When the unit is properly equipped with the field-installed damper kit and other customer-supplied accessories, the air intake is based on the customer setpoint.

Normal Function

During normal operation, the damper takes in air from the room only, closing the outdoor air intake. The fan sends air over the cooling coil and into the room. Cooling is through the cooling cycle (starting the compressor) and controlled by the thermostat.

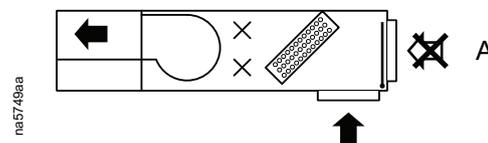

Free-Cooling

When the outdoor air temperature is low enough to maintain room temperature at the desired level, the damper changes position, delivering into the room outdoor air instead of recycled. During free-cooling operation, the compressor is off.

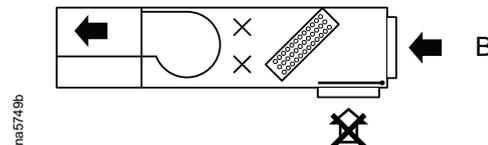

Modulated Function

When the outdoor temperature falls further, the introduction of 100% outdoor air causes return air temperatures that are too low. The control system changes the position of the damper to mix outdoor and recycled air to maintain the temperature in the room at the required level. The temperature of the return air is maintained above a pre-set minimum.

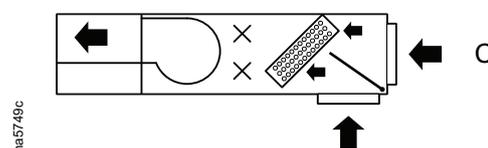

Component Identification

External Components

Indoor Units

UCF0341I and UCF0481I

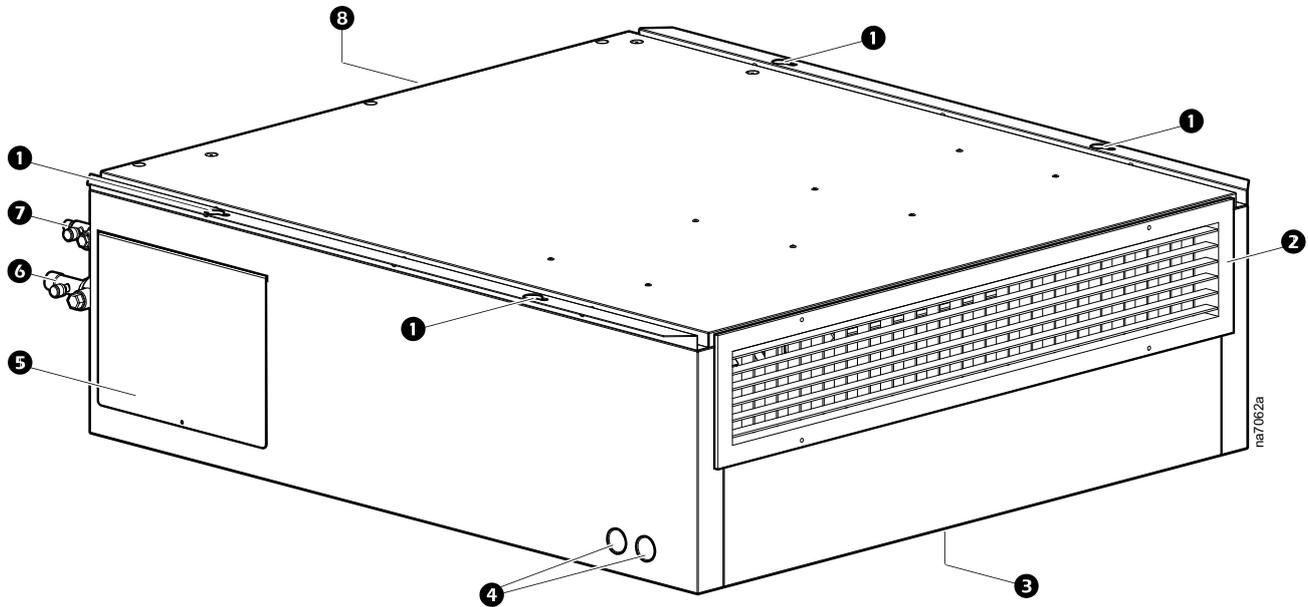

NOTE: Model shown is UCF0341I.

Item	Description	Item	Description
1	Mounting holes	5	Service panel
2	Fan protection grille	6	Suction line service valve
3	Electrical panel cover (on bottom of unit)	7	Liquid line service valve
4	Low-voltage conduit knock-out panels*	8	Damper connection cover panel (on rear of unit)

* High-voltage conduit knock-out panels are located on the opposite side.

Outdoor Units

MRA0221I

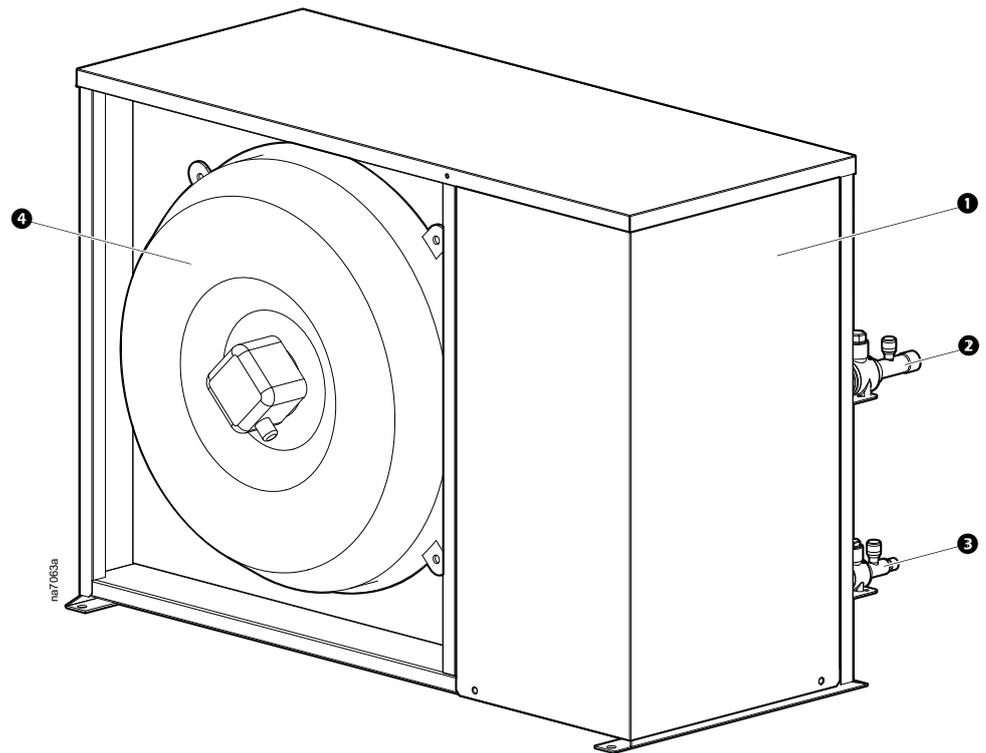

Item	Description
①	External panel
②	Suction line
③	Liquid line
④	Fan protection grille

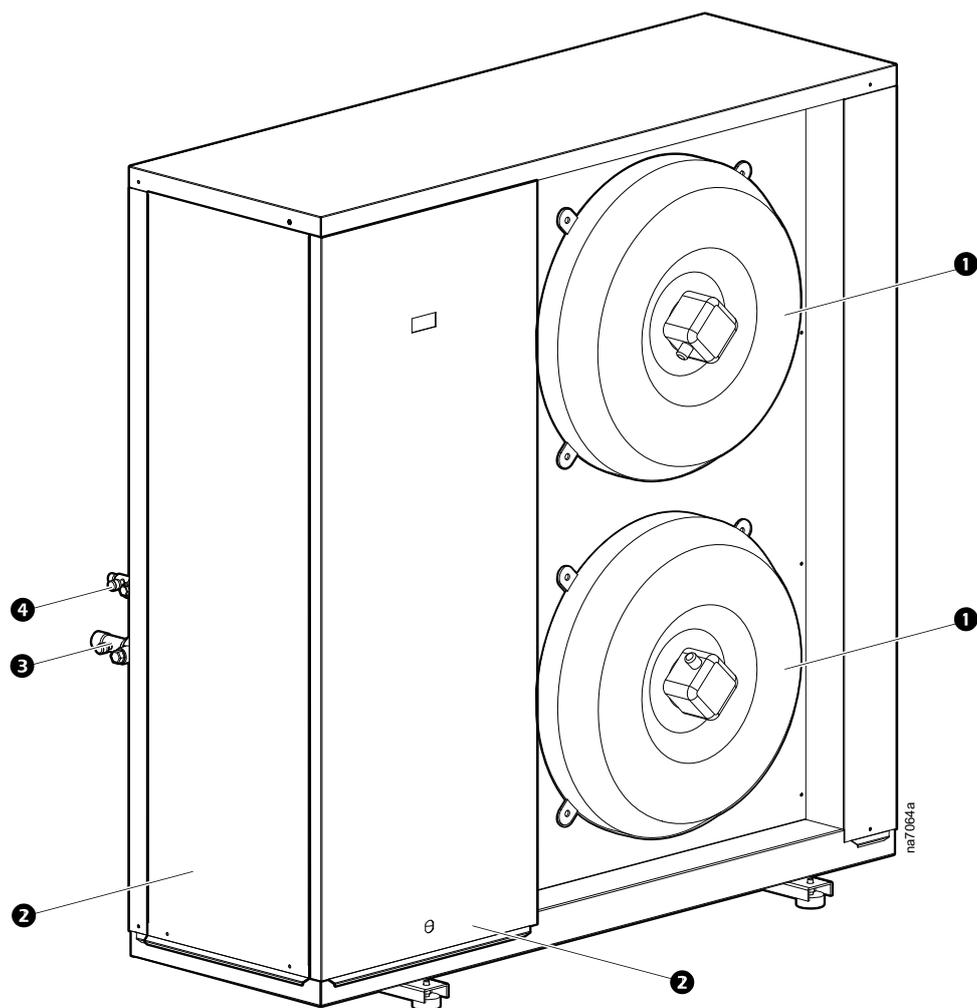
MRA0661D

Item	Description
1	Fan protection grille
2	External panels
3	Suction line connection
4	Liquid line connection

Internal Components

Indoor Units

UCF0341I

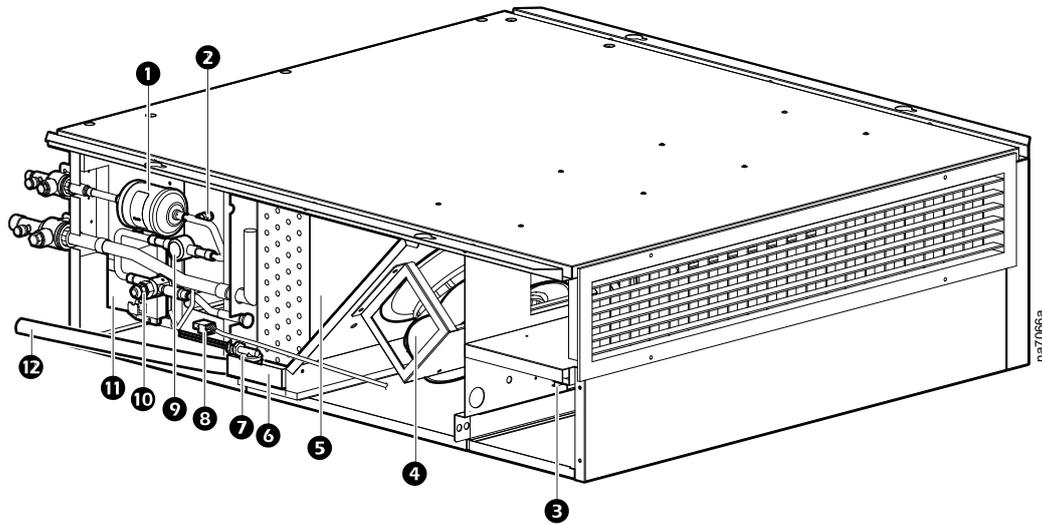

Item	Description	Item	Description
1	Filter drier	7	Float switch
2	Service port	8	Direct Air Economizer damper actuator connection (optional)
3	Electrical panel (facing bottom of unit)	9	Sight glass
4	Evaporative fans	10	Thermostatic expansion valve (TXV)
5	Evaporative coil	11	Motorized free-cooling damper actuator (optional with damper kit)
6	Condensate drain pan	12	Condensate drain hose

UCF0481I

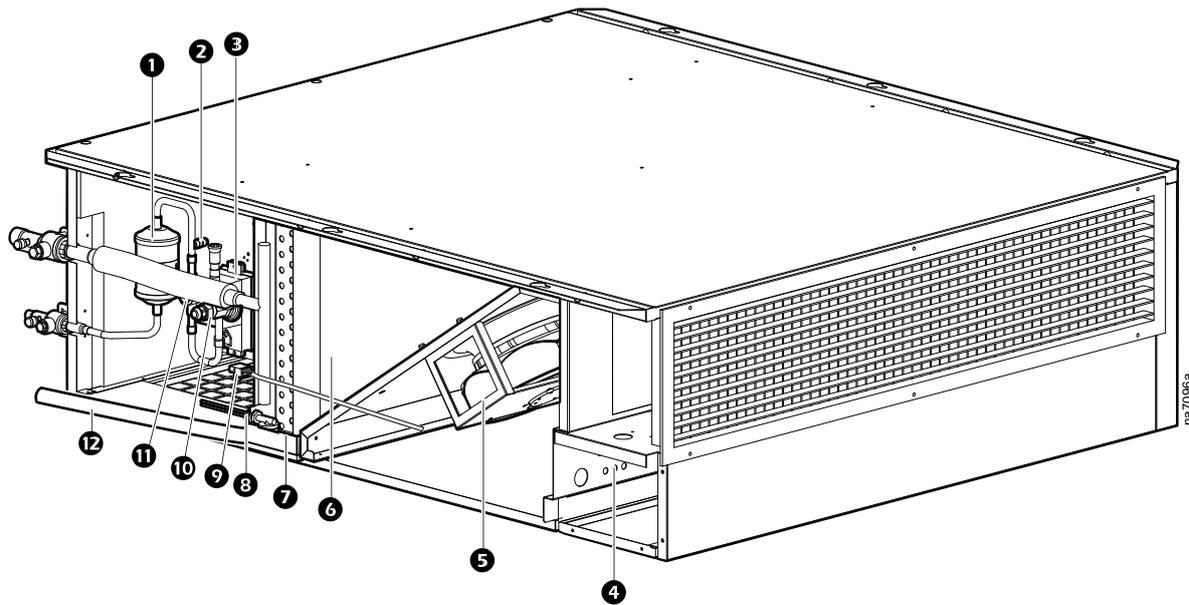

na7096a

Item	Description	Item	Description
1	Filter drier	7	Condensate drain pan
2	Service port	8	Float switch
3	Motorized free-cooling damper actuator (optional with damper kit)	9	Direct Air Economizer damper actuator connection (optional)
4	Electrical panel (facing bottom of unit)	10	Thermostatic expansion valve (TXV)
5	Evaporative fans	11	Sight glass
6	Evaporative coil	12	Condensate drain hose

Outdoor Units

MRA0221I

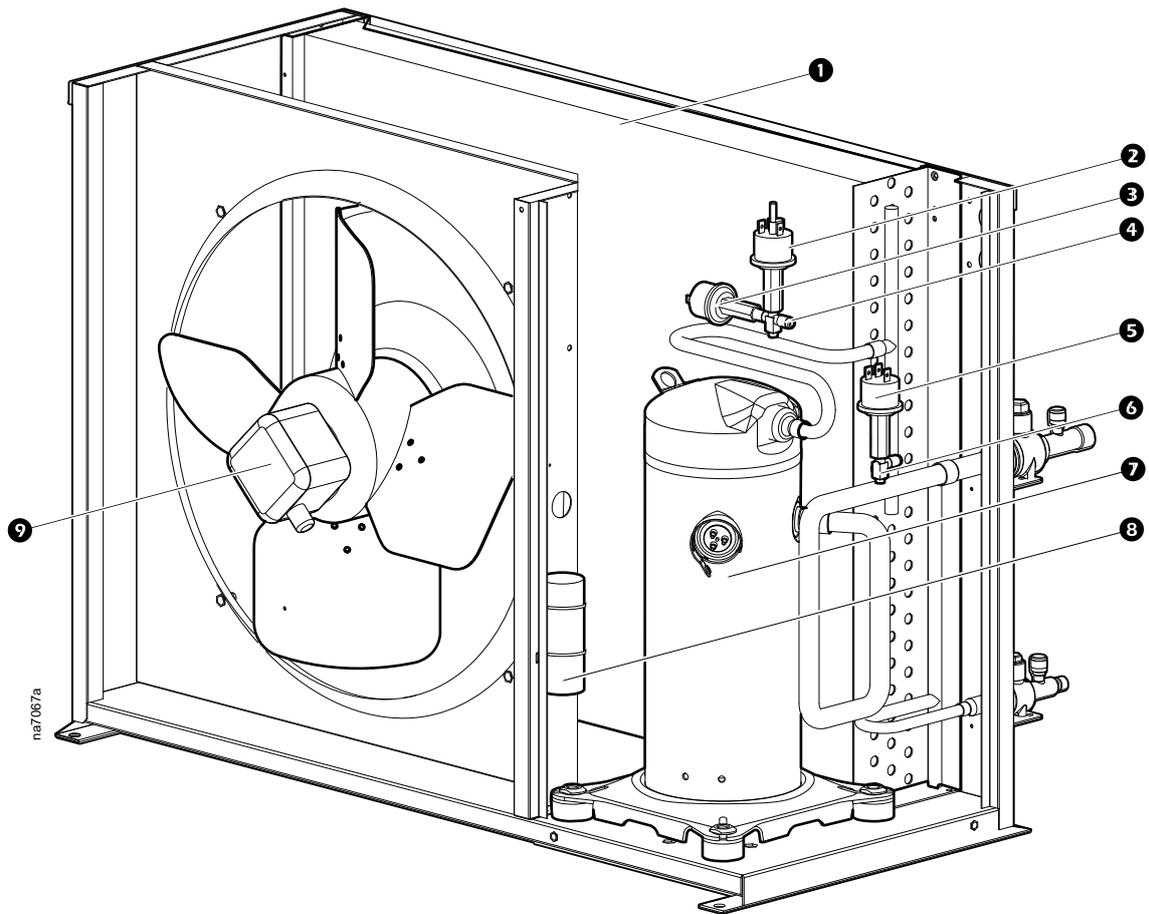

Item	Description	Item	Description
1	Condensing coil	6	Suction service port
2	High-pressure switch	7	Scroll compressor
3	Pressure transducer	8	Capacitor
4	Discharge service port	9	Condensing fan
5	Low-pressure switch		

NOTE: Crankcase heater and compressor blanket are not shown.

MRA0611D

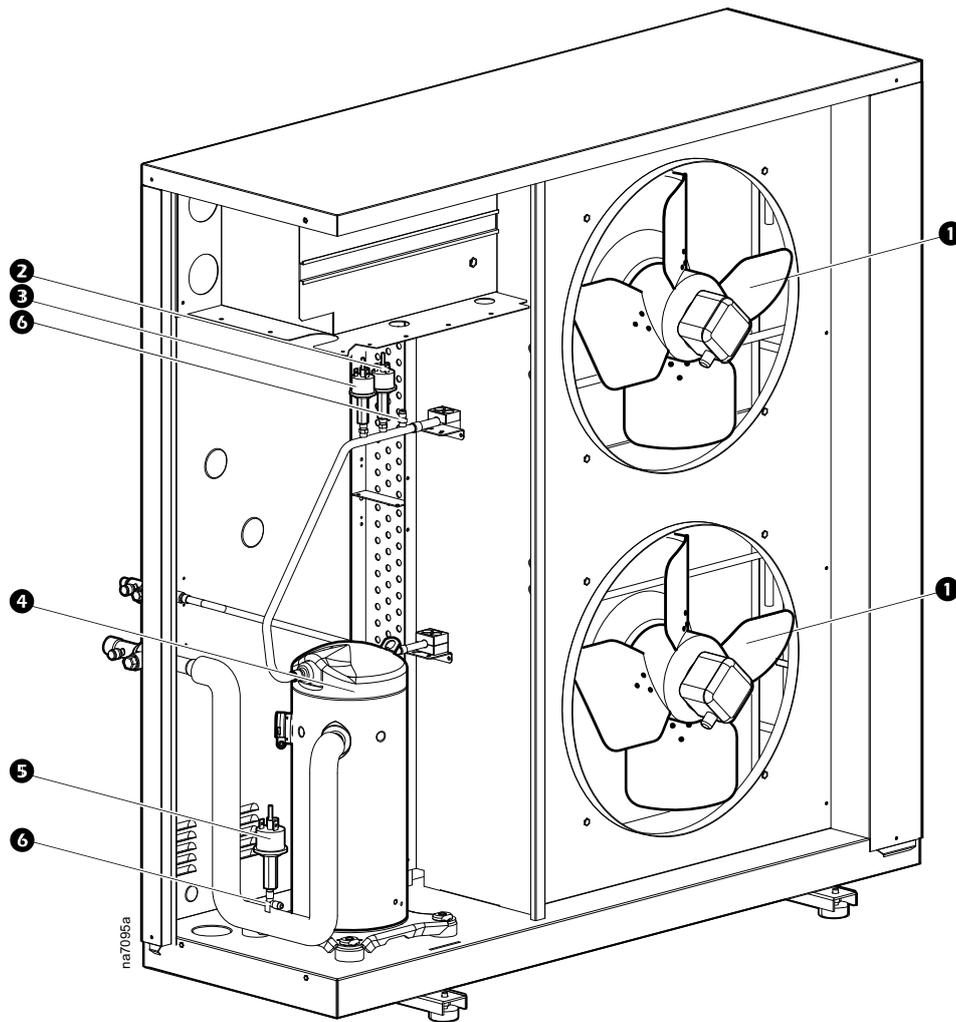

Item	Description	Item	Description
1	Condensing fans	4	Scroll compressor
2	High-pressure switch	5	Low-pressure switch
3	Pressure transducer	6	Service port

NOTE: Crankcase heater and compressor blanket are not shown.

Electrical Panels

Indoor Units

UCF0341I, UCF0481I

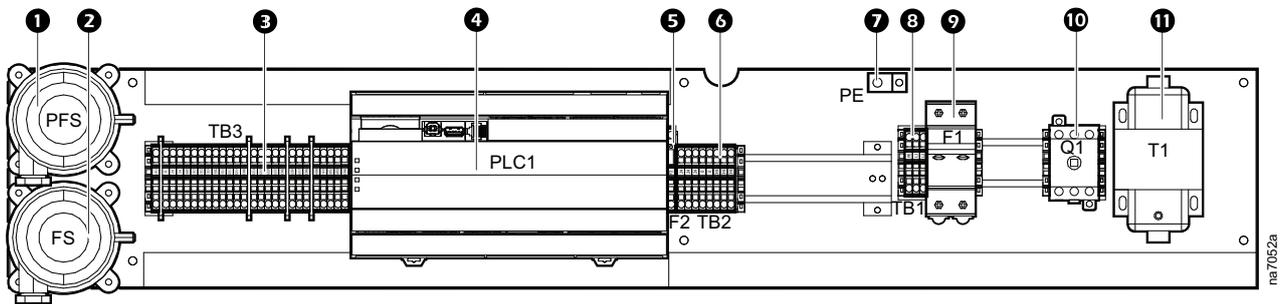

Item	Description	Item	Description
1	Clogged filter pressure switch (PFS)	7	Ground (PE)
2	Air flow pressure switch (FS)	8	Terminal block (TB1)
3	Terminal block (TB3)	9	Fuse (F1)
4	J5 controller (PLC1)	10	Internal power disconnect switch (Q1)
5	Fuse (F2)	11	Transformer (T1)
6	Terminal block (TB2)		

Outdoor Units

MRA0221I

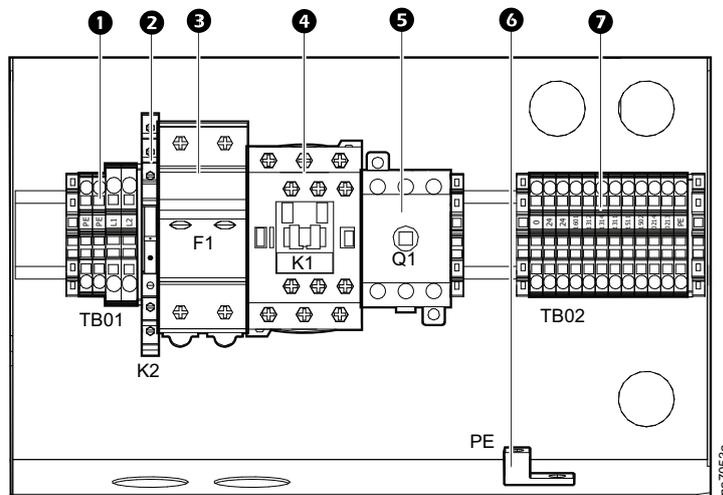

Item	Description	Item	Description
1	Terminal block (TB01)	5	Internal power disconnect switch (Q1)
2	Voltage presence relay (K2)	6	Ground (PE)
3	Fuse (F1)	7	Terminal block (TB02)
4	Compressor contactor (K1)		

MRA0611D

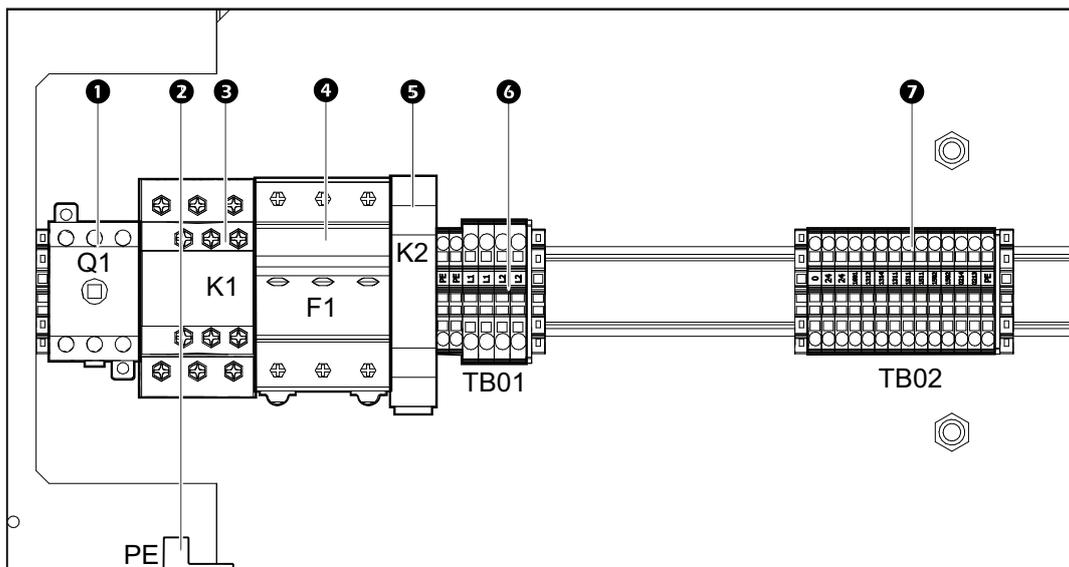

na7054a

Item	Description	Item	Description
1	Internal power disconnect switch (Q1)	5	Voltage presence relay/3-phase monitor (K2)
2	Ground (PE)	6	Terminal block (TB01)
3	Compressor contactor (K1)	7	Terminal block (TB02)
4	Fuse (F1)		

Display Interface

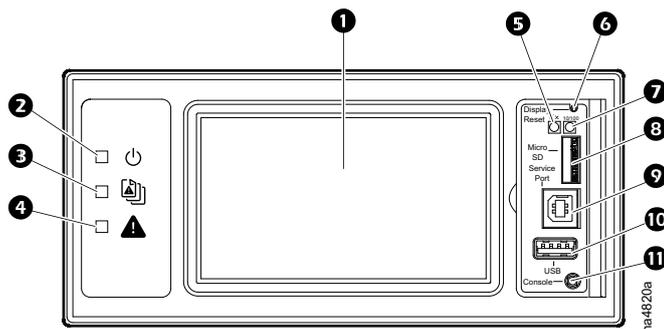

Item	Description	Function
1	LCD Display	4.3-inch touch-screen color display
2	Power LED	The cooling unit is powered when the LED is illuminated. Unit firmware is updating when LED is blinking.
3	Check Log LED	When this LED is illuminated, a new entry has been made to the event log.
4	Alarm LED	Displays current alarm condition of unit.
5	Status LED	Displays current network management card status.
6	Display Reset button	Resets the display microprocessor. This has no effect on the air conditioner controller.
7	Link-RX/TX (10/100) LED	Displays current network link status.
8	Micro SD card slot	Memory card expansion slot.
9	Service port	USB-B port used only by service personnel.
10	USB-A port	Supports firmware upgrades.
11	Serial Configuration port	Connects the display to a local computer to configure initial network settings or access the command line interface (CLI).

Alarm LED

This LED indicates active alarms on the display.

Condition	Description
Off	No alarm
Solid yellow	Warning alarm
Solid red	Critical alarm

Status LED

This LED indicates the status of the display.

Condition	Description
Off	One of the following situations exist: <ul style="list-style-type: none"> The display is not receiving input power. The display is not operating properly. It may need to be repaired or replaced. Contact Schneider ElectricTrane Customer Support.
Solid green	The display has valid TCP/IP settings.
Solid orange	A hardware malfunction has been detected in the display. Contact Schneider ElectricTrane Customer Support.
Flashing green	The display does not have valid TCP/IP settings.
Flashing orange	The display is making BOOTP requests.
Alternately flashing green and orange	If the LED is flashing slowly, the display is making DHCP requests. If the LED is flashing rapidly, the display is starting up.

Link-RX/TX (10/100) LED

This LED indicates the network status of the display.

Condition	Description
Off	One or more of the following situations exist: <ul style="list-style-type: none"> The display is not receiving input power. The cable or device that connects the cooling unit to the network is disconnected or not functioning properly. The display itself is not operating properly. It may need to be repaired or replaced. Contact Schneider ElectricTrane Customer Support.
Solid green	The display is connected to a network operating at 10 megabits per second (Mbps).
Solid orange	The display is connected to a network operating at 100 Mbps.
Flashing green	The display is receiving or transmitting at 10 Mbps.
Flashing orange	The display is receiving data packets at 100 Mbps.

Performance Specifications

Cooling Capacity

Ratings shown are based on 208 volt, 60 Hz operation.

	UCF0341I and MRA0221I*	UCF0481I and MRA0661D**
Outdoor DB 23.8°C (75°F), Return Air Temperature 26.6°C (80°F), 50% RH		
Total – kW (BTU/hr)	7.27 (25,000)	15.44 (53,000)
Sensible – kW (BTU/hr)	5.91 (20,000)	11.96 (41,000)
Sensible Heat Ratio (SHR)	0.81	0.77
Outdoor DB 23.8°C (75°F), Return Air Temperature 26.6°C (80°F), 45% RH		
Total – kW (BTU/hr)	7.14 (24,000)	15.08 (52,000)
Sensible – kW (BTU/hr)	6.34 (22,000)	13.06 (45,000)
Sensible Heat Ratio (SHR)	0.89	0.87
Outdoor DB 23.8°C (75°F), Return Air Temperature 23.9°C (75°F), 50% RH		
Total – kW (BTU/hr)	6.82 (23,000)	14.40 (49,000)
Sensible – kW (BTU/hr)	5.74 (20,000)	11.67 (40,000)
Sensible Heat Ratio (SHR)	0.84	0.81
Outdoor DB 23.8°C (75°F), Return Air Temperature 23.9°C (75°F), 45% RH		
Total – kW (BTU/hr)	6.69 (23,000)	14.04 (48,000)
Sensible – kW (BTU/hr)	6.17 (22,000)	12.41 (42,000)
Sensible Heat Ratio (SHR)	0.92	0.88
Outdoor DB 23.8°C (75°F), Return Air Temperature 22.2°C (72°F), 50% RH		
Total – kW (BTU/hr)	6.54 (22,000)	13.78 (47,000)
Sensible – kW (BTU/hr)	5.59 (19,000)	11.49 (39,000)
Sensible Heat Ratio (SHR)	0.85	0.83
Outdoor DB 23.8°C (75°F), Return Air Temperature 22.2°C (72°F), 45% RH		
Total – kW (BTU/hr)	6.42 (22,000)	13.42 (46,000)
Sensible – kW (BTU/hr)	6.03 (21,000)	12.02 (41,000)
Sensible Heat Ratio (SHR)	0.94	0.90
Outdoor DB 23.8°C (75°F), Return Air Temperature 21.1°C (70°F), 50% RH		
Total – kW (BTU/hr)	6.36 (22,000)	13.36 (48,000)
Sensible – kW (BTU/hr)	5.48 (19,000)	11.38 (39,000)
Sensible Heat Ratio (SHR)	0.86	0.85

*Data is measured at an air flow rate of 1700 m³/h (1000 SCFM).

**Data is measured at an air flow rate of 3058 m³/h (1800 SCFM).

	UCF0341I and MRA0221I*	UCF0481I and MRA0661D**
Outdoor DB 23.8°C (75°F), Return Air Temperature 21.1°C (70°F), 45% RH		
Total – kW (BTU/hr)	6.24 (21,000)	13.00 (44,000)
Sensible – kW (BTU/hr)	5.91 (20,000)	11.77 (40,000)
Sensible Heat Ratio (SHR)	0.95	0.90
Outdoor DB 29.4°C (85°F), Return Air Temperature 26.6°C (80°F), 50% RH		
Total – kW (BTU/hr)	7.21 (25,000)	14.87 (51,000)
Sensible – kW (BTU/hr)	5.88 (20,000)	11.72 (6000)
Sensible Heat Ratio (SHR)	0.82	0.79
Outdoor DB 29.4°C (85°F), Return Air Temperature 26.6°C (80°F), 45% RH		
Total – kW (BTU/hr)	7.08 (24,000)	14.50 (49,000)
Sensible – kW (BTU/hr)	6.31 (22,000)	12.81 (44,000)
Sensible Heat Ratio (SHR)	0.89	0.88
Outdoor DB 29.4°C (85°F), Return Air Temperature 23.9°C (75°F), 50% RH		
Total – kW (BTU/hr)	6.75 (23,000)	13.83 (47,000)
Sensible – kW (BTU/hr)	5.71 (19,000)	11.43 (39,000)
Sensible Heat Ratio (SHR)	0.84	0.83
Outdoor DB 29.4°C (85°F), Return Air Temperature 23.9°C (75°F), 45% RH		
Total – kW (BTU/hr)	6.63 (23,000)	13.47 (46,000)
Sensible – kW (BTU/hr)	6.14 (21,000)	12.17 (42,000)
Sensible Heat Ratio (SHR)	0.93	0.90
Outdoor DB 29.4°C (85°F), Return Air Temperature 22.2°C (72°F), 50% RH		
Total – kW (BTU/hr)	6.48 (22,000)	13.20 (45,000)
Sensible – kW (BTU/hr)	5.56 (19,000)	11.25 (38,000)
Sensible Heat Ratio (SHR)	0.86	0.85
Outdoor DB 29.4°C (85°F), Return Air Temperature 22.2°C (72°F), 45% RH		
Total – kW (BTU/hr)	6.36 (22,000)	12.84 (44,000)
Sensible – kW (BTU/hr)	5.99 (20,000)	11.78 (41,000)
Sensible Heat Ratio (SHR)	0.94	0.92
Outdoor DB 29.4°C (85°F), Return Air Temperature 21.1°C (70°F), 50% RH		
Total – kW (BTU/hr)	6.30 (21,000)	12.79 (44,000)
Sensible – kW (BTU/hr)	5.45 (19,000)	11.13 (38,000)
Sensible Heat Ratio (SHR)	0.86	0.87

*Data is measured at an air flow rate of 1700 m³/h (1000 SCFM).

**Data is measured at an air flow rate of 3058 m³/h (1800 SCFM).

	UCF0341I and MRA0221I*	UCF0481I and MRA0661D**
Outdoor DB 29.4°C (85°F), Return Air Temperature 21.1°C (70°F), 45% RH		
Total – kW (BTU/hr)	6.17 (21,000)	12.43 (42,000)
Sensible – kW (BTU/hr)	5.88 (20,000)	11.52 (39,000)
Sensible Heat Ratio (SHR)	0.95	0.93
Outdoor DB 35.0°C (95°F), Return Air Temperature 26.6°C (80°F), 50% RH		
Total – kW (BTU/hr)	6.88 (23,000)	14.13 (48,000)
Sensible – kW (BTU/hr)	5.76 (20,000)	11.40 (39,000)
Sensible Heat Ratio (SHR)	0.84	0.81
Outdoor DB 35.0°C (95°F), Return Air Temperature 26.6°C (80°F), 45% RH		
Total – kW (BTU/hr)	6.75 (22,000)	13.76 (47,000)
Sensible – kW (BTU/hr)	6.19 (21,000)	12.50 (43,000)
Sensible Heat Ratio (SHR)	0.92	0.91
Outdoor DB 35.0°C (95°F), Return Air Temperature 23.9°C (75°F), 50% RH		
Total – kW (BTU/hr)	6.42 (22,000)	13.09 (47,000)
Sensible – kW (BTU/hr)	5.59 (19,000)	11.11 (38,000)
Sensible Heat Ratio (SHR)	0.87	0.85
Outdoor DB 35.0°C (95°F), Return Air Temperature 23.9°C (75°F), 45% RH		
Total – kW (BTU/hr)	6.30 (21,000)	12.73 (43,000)
Sensible – kW (BTU/hr)	6.02 (21,000)	11.85 (40,000)
Sensible Heat Ratio (SHR)	0.96	0.93
Outdoor DB 35.0°C (95°F), Return Air Temperature 22.2°C (72°F), 50% RH		
Total – kW (BTU/hr)	6.15 (21,000)	12.46 (43,000)
Sensible – kW (BTU/hr)	5.45 (19,000)	10.94 (37,000)
Sensible Heat Ratio (SHR)	0.89	0.88
Outdoor DB 35.0°C (95°F), Return Air Temperature 22.2°C (72°F), 45%RH		
Total – kW (BTU/hr)	6.03 (21,000)	12.10 (41,000)
Sensible – kW (BTU/hr)	5.88 (20,000)	11.47 (39,000)
Sensible Heat Ratio (SHR)	0.98	0.95
Outdoor DB 35.0°C (95°F), Return Air Temperature 21.1°C (70°F), 50% RH		
Total – kW (BTU/hr)	5.97 (20,000)	12.05 (41,000)
Sensible – kW (BTU/hr)	5.33 (18,000)	10.82 (37,000)
Sensible Heat Ratio (SHR)	0.89	0.90

*Data is measured at an air flow rate of 1700 m³/h (1000 SCFM).

**Data is measured at an air flow rate of 3058 m³/h (1800 SCFM).

	UCF0341I and MRA0221I*	UCF0481I and MRA0661D**
Outdoor DB 35.0°C (95°F), Return Air Temperature 21.1°C (70°F), 45% RH		
Total – kW (BTU/hr)	5.85 (20,000)	11.69 (40,000)
Sensible – kW (BTU/hr)	5.76 (20,000)	11.21 (38,000)
Sensible Heat Ratio (SHR)	0.99	0.96
Outdoor DB 40.5°C (105°F), Return Air Temperature 26.6°C (80°F), 50% RH		
Total – kW (BTU/hr)	6.51 (22,000)	13.22 (45,000)
Sensible – kW (BTU/hr)	5.52 (18,000)	11.02 (38,000)
Sensible Heat Ratio (SHR)	0.85	0.83
Outdoor DB 40.5°C (105°F), Return Air Temperature 26.6°C (80°F), 45% RH		
Total – kW (BTU/hr)	6.38 (22,000)	12.86 (44,000)
Sensible – kW (BTU/hr)	5.95 (20,000)	12.11 (41,000)
Sensible Heat Ratio (SHR)	0.93	0.94
Outdoor DB 40.5°C (105°F), Return Air Temperature 23.9°C (75°F), 50% RH		
Total – kW (BTU/hr)	6.06 (21,000)	12.18 (42,000)
Sensible – kW (BTU/hr)	5.35 (18,000)	10.73 (37,000)
Sensible Heat Ratio (SHR)	0.88	0.88
Outdoor DB 40.5°C (105°F), Return Air Temperature 23.9°C (75°F), 45% RH		
Total – kW (BTU/hr)	5.93 (20,000)	11.82 (40,000)
Sensible – kW (BTU/hr)	5.78 (20,000)	11.47 (39,000)
Sensible Heat Ratio (SHR)	0.97	0.97
Outdoor DB 40.5°C (105°F), Return Air Temperature 22.2°C (72°F), 50% RH		
Total – kW (BTU/hr)	5.79 (20,000)	11.56 (39,000)
Sensible – kW (BTU/hr)	5.21 (17,000)	10.55 (36,000)
Sensible Heat Ratio (SHR)	0.90	0.91
Outdoor DB 40.5°C (105°F), Return Air Temperature 22.2°C (72°F), 45% RH		
Total – kW (BTU/hr)	5.66 (19,000)	11.20 (38,000)
Sensible – kW (BTU/hr)	5.64 (19,000)	11.08 (38,000)
Sensible Heat Ratio (SHR)	1.00	0.99
Outdoor DB 40.5°C (105°F), Return Air Temperature 21.1°C (70°F), 50% RH		
Total – kW (BTU/hr)	5.60 (19,000)	11.14 (38,000)
Sensible – kW (BTU/hr)	5.09 (17,000)	10.43 (36,000)
Sensible Heat Ratio (SHR)	0.91	0.94
Outdoor DB 40.5°C (105°F), Return Air Temperature 21.1°C (70°F), 50% RH		
Total – kW (BTU/hr)	5.48 (19,000)	10.78 (37,000)
Sensible – kW (BTU/hr)	5.48 (19,000)	10.78 (37,000)
Sensible Heat Ratio (SHR)	1.00	1.00

*Data is measured at an air flow rate of 1700 m³/h (1000 SCFM).

**Data is measured at an air flow rate of 3058 m³/h (1800 SCFM).

Electrical Data

Indoor Units

Overall Unit

Model	UCF0341I	UCF0481I
Voltage	208 V, 1 Ph, 60 Hz 230 V, 1 Ph, 60 Hz	
FLA (A)	3.0	4.5
MCA (A)	4.5	6.4
MOP (A)	15	15

FLA: Full Load Amps

MCA: Minimum Circuit Amps

MOP: Maximum Overcurrent Protection

Fans

Model	UCF0341I	UCF0481I
Quantity	2	3
FLA (A)	1.5	1.5

FLA: Full Load Amps

Outdoor Units

Overall Unit

Model	MRA0221I	MRA0611D
Voltage	208 V, 1 Ph, 60 Hz 230 V, 1 Ph, 60 Hz	208 V, 3 Ph, 60 Hz 230 V, 3 Ph, 60 Hz
FLA (A)	16.4	23.1
MCA (A)	19.6	27.0
MOP (A)	30.0	40.0

FLA: Full Load Amps

MCA: Minimum Circuit Amps

MOP: Maximum Overcurrent Protection

Compressor

Model	MRA0221I	MRA0611D
Quantity	1	1
LRA (A)	64.0	110.0
RLA (A)	12.8	15.9

LRA: Locked Rotor Amps

RLA: Rated Load Amps

Axial Fans

Model	MRA0221I	MRA0611D
Quantity	1	2
FLA (A)	3.6	3.6

FLA: Full Load Amps

Dimensions and Weights

Indoor Units

UCF0341I, UCF0481I

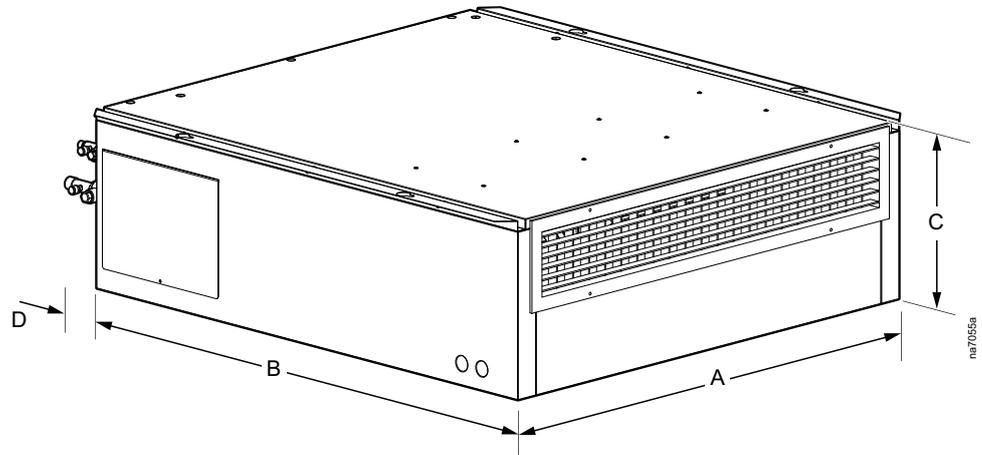

Model	Dimensions – mm (in.)				Net Weight – kg (lb)
	A	B	C	D	
UCF0341I	950 (37.4)	1050 (41.3)	330 (13.0)	125 (4.9)	75 (165.4)
UCF0481I	1150 (45.3)	1300 (51.2)	411 (16.2)	124 (4.8)	146 (321.9)

Outdoor Units

MRA0221I

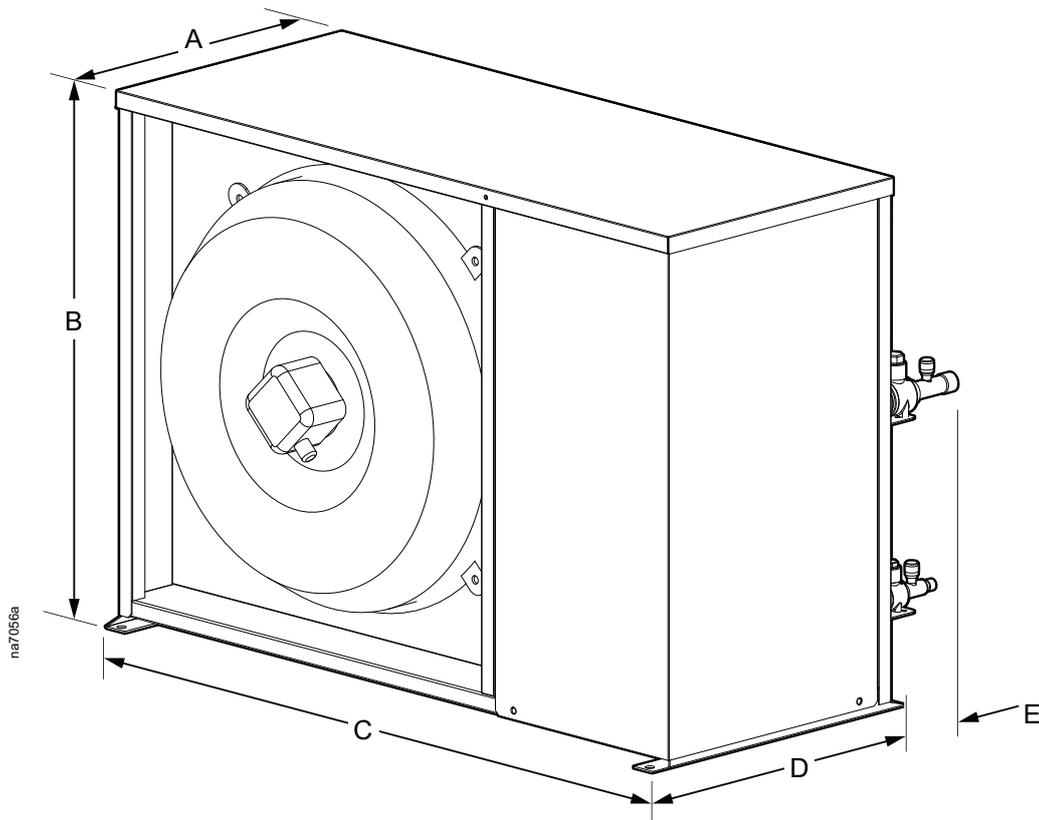

Model	Dimensions – mm (in.)					Net Weight – kg (lb)
	A	B	C	D	E	
MRA0221I	349.0 (13.7)	610.1 (24.0)	854.0 (33.6)	390.0 (15.4)	125.0 (4.9)	105 (231.5)

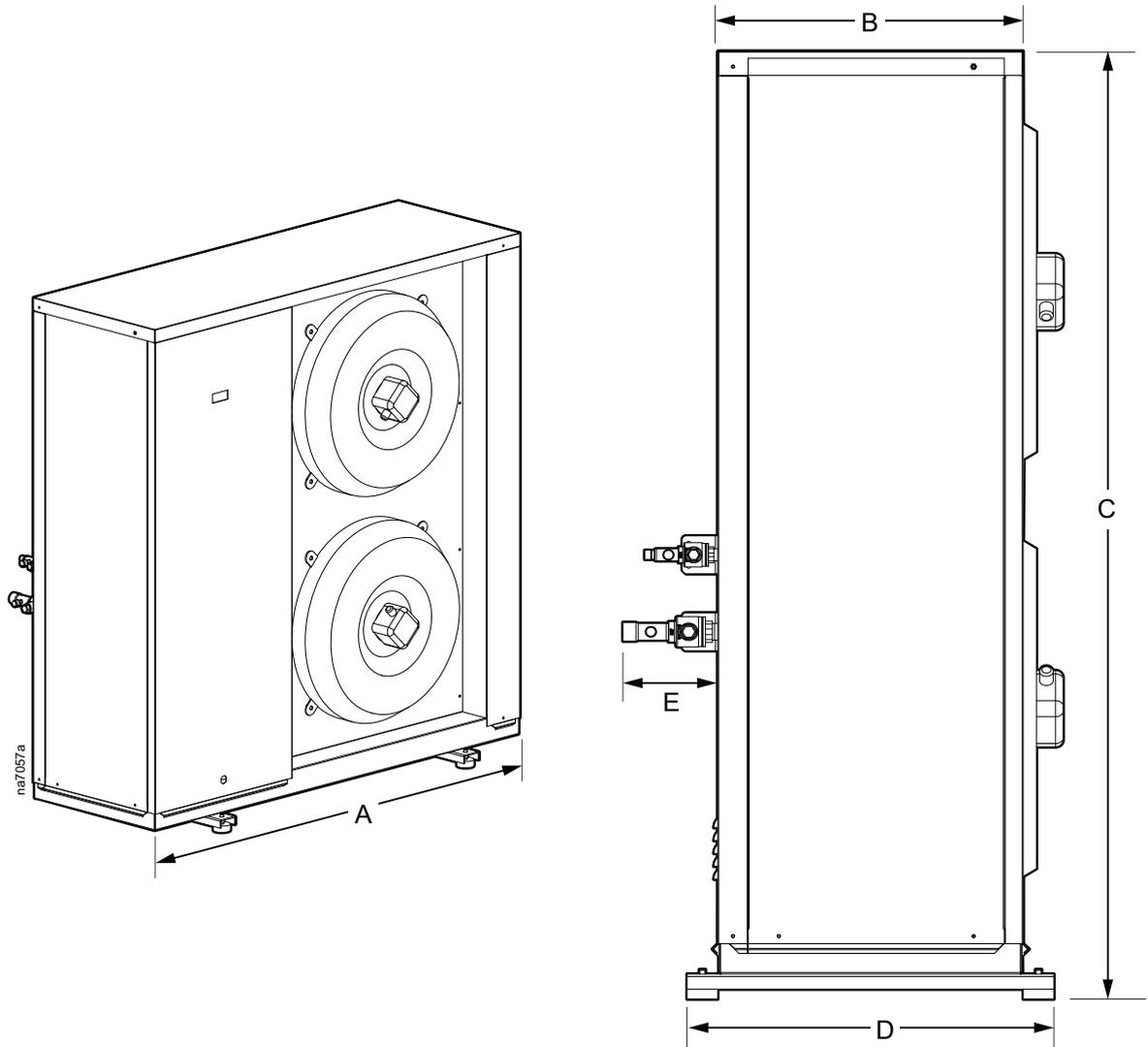
MRA0611D

Model	Dimensions – mm (in.)					Net Weight – kg (lb)
	A	B	C	D	E	
MRA0611D	1200 (47.2)	400.0 (15.7)	1250.5 (49.2)	480.0 (18.9)	124.0 (4.9)	140 (308.7)

Schneider Electric
35 rue Joseph Monier
92500 Rueil Malmaison
France

+ 33 (0) 1 41 29 70 00

www.schneider-electric.com

As standards, specifications, and design change from time to time,
please ask for confirmation of the information given in this publication.

© 2018 – 2019 Schneider Electric. All rights reserved.

990-91231A-001