

ION8650 series Technical Datasheet

Providing high accuracy and a wide range of features for transmission and distribution metering, the PowerLogic ION8650 advanced revenue and power quality meter has the flexibility to change along with your needs. The meter provides the tools necessary to:

- Manage energy procurement and supply contracts
- Perform network capacity planning and stability analysis
- Monitor power quality compliance, supply agreements, and regulatory requirements

Applications

- Transmission and distribution metering
- Revenue metering
- Extensive power quality monitoring and analysis
- Power quality compliance monitoring
- Digital fault recording
- Instrument transformer correction



[S8650A](#)

PR107500

The solution for

Markets that can benefit from a solution that includes PowerLogic ION8650 series meters:

- Transmission networks
- Distribution network

Benefits

- Reduce operations costs
- Improve power quality
- Improve continuity of service

Competitive advantages

- Be integrated into existing wholesale settlement system
- Be able to use Power Monitoring Expert software for data analysis or share operation data with SCADA systems through multiple communication channels and protocols
- Transformer/line loss compensation
- Instrument transformer correction

Power management solutions

Schneider Electric provides innovative power management solutions to increase your energy efficiency and cost savings, maximise electrical network reliability and availability, and optimise electrical asset performance.

Conformity of standards

- IEC 62053-22/23
- IEC 61000-4-4
- IEC 61000-4-30
- IEC 61000-4-5
- EN 50160
- IEC 61000-4-6
- IEC 61000-4-7
- IEC 61000-4-12
- IEC 61000-4-15
- CISPR 22
- IEEE 1159
- IEC 62052-11
- IEEE 519
- IEC 60950
- IEC 61000-4-2
- ANSI C12.20
- IEC 61000-4-3

PB107500



PowerLogic ION8650 socket meter

Main characteristics

Used to monitor electric energy provider networks, service entrances and substations, PowerLogic ION8650 meters are ideal for independent power producers and cogeneration applications that need to accurately measure energy bi-directionally in both generation and stand-by modes. These meters give utilities the tools to manage complex energy supply contracts that include commitments to power quality. Integrate them with our EcoStruxure™ Power Monitoring operations software or other energy management and SCADA systems through multiple communication channels and protocols, including Itron MV-90, Modbus, DNP, DLMS, IEC 61850 Ed. 3.

Applications

- Revenue metering.
- Cogeneration and IPP monitoring.
- Compliance monitoring.
- Power quality analysis.
- Demand and power factor control.
- Load curtailment.
- Equipment monitoring and control.
- Energy pulsing and totalisation.
- Instrument transformer correction.
- Outage Notification

Main characteristics

- ANSI Class 0.1 and IEC 62053-22/23 Class 0.2 S metering
 - For interconnection points on medium, high, and ultra-high voltage networks; twice as accurate as current IEC and meets ANSI Class standards over all conditions and including single wide range current measurement.
- Power quality compliance monitoring
 - Monitor compliance with international quality-of-supply standards (IEC 61000-4-30 Ed. 3 Class A/S, EN 50160 Ed. 4, IEC 61000-4-7, IEC 61000-4-15, IEEE 1159, IEEE 519). Also detects disturbance direction.
- Digital fault recording
 - Simultaneous capture of voltage and current channels for sub-cycle disturbance.
- Complete communications
 - Multi-port, multi-protocol ports including serial, infrared, modem and ethernet. Simultaneously supports multiple industry standard protocols including: Itron MV-90, Modbus, Modbus Master, DLMS, DNP 3.0 and IEC 61850 Ed. 2.
- Multiple tariffs and time-of-use
 - Apply tariffs, seasonal rate schedules to measure energy and demand values for time periods with specific billing requirements.
- Multiple setpoints for alarm and functions
 - Use up to 65 setpoints for single/multi-condition alarms and I/O functions with response times down to 1/2 cycle.
- Multiple setpoints for alarm and functions
 - Use up to 65 setpoints.
- Instrument transformer correction
 - Save money and improve accuracy by correcting for less accurate transformers.
- Alarm notification via email
 - High-priority alarms, data logs sent directly to the user's PC. Instant notification of power quality events by email.
- Cyber security enhancements
 - Assign communication admin rights to selected user; prevention measures ensure no loss of security logs; support syslog for external security.

Feature selection	
Commercial reference number	ION8650 meters
S8650A	ION8650A
S8650B	ION8650B
S8650C	ION8650C



PowerLogic ION8650 switchboard meter.

- 1 Terminals
- 2 Optical port
- 3 Main display status bar
- 4 Watt LED
- 5 Navigation, ALT/Enter buttons
- 6 VAR LED
- 7 Nameplate label
- 8 Demand reset switch

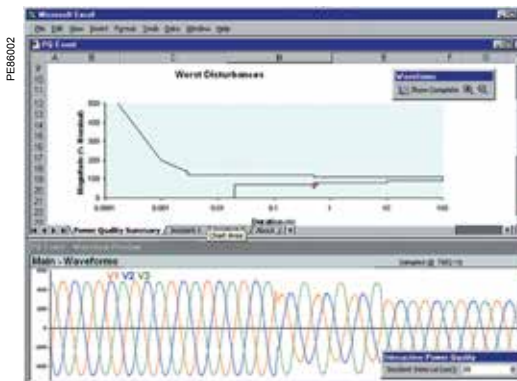

Disturbance waveform capture and power quality report

Selection guide		ION8650 A	ION8650 B	ION8650 C
General				
Use on LV, MV and HV systems		■	■	■
Current accuracy		0.1 %	0.1 %	0.1 %
Voltage accuracy		0.1 %	0.1 %	0.1 %
Power accuracy		0.1 %	0.1 %	0.1 %
Samples/cycle		1024	1024	1024
Instantaneous values				
Current, voltage, frequency		■	■	■
Active, reactive, apparent power Total & per phase		■	■	■
Power factor Total & per phase		■	■	■
Current measurement range		0 A - 20 A	0 A - 20 A	0 A - 20 A
Energy values				
Active, reactive, apparent energy		■	■	■
Settable accumulation modes		■	■	■
Demand values				
Current Present & max values		■	■	■
Active, reactive, apparent power Present & max values		■	■	■
Predicted active, reactive, apparent power		■	■	■
Synchronisation of the measurement window		■	■	■
Demand modes: Block (sliding), thermal (exponential)		■	■	■
Power quality measurements				
Harmonic distortion Current & voltage		■	■	■
Individual harmonics Via front panel		63	63	31
Waveform / transient capture		■ / ■	- / ■	- / -
Harmonics: magnitude, phase, and interharmonics		50	40	-
Detection of voltage sags and swells		■	■	■
IEC 61000-4-30 class A / S		A	S	-
IEC 61000-4-15 (Flicker)		■	■	-
High speed data recording (down to 10 ms)		■	■	-
EN 50160 compliance reporting		■	■	-
Programmable (logic and math functions)		■	■	■
Data recording				
Onboard Memory (in Mbytes)		128	64	32
Revenue logs		■	■	■
Event logs		■	■	■
Historical logs		■	■	■
Harmonics logs		■	■	■
Sag/swell logs		■	■	■
Transient logs		■	-	-
Time stamping to 1 ms		■	■	■
GPS synchronisation (IRIG-B standard)		■	■	■
Display and I/O				
Front panel display		■	■	■
Wiring self-test (requires PowerLogic ION Setup)		■	■	■
Pulse output (front panel LED)		2	2	2
Digital or analogue inputs* (max)		11	11	11
Digital or analogue outputs* (max, including pulse output)		16	16	16
Communication				
Infrared port		1	1	1
RS-485 / RS-232 port		1	1	1***
RS-485 port		1	1	1***
Ethernet port (Modbus/TCP/IP protocol) with gateway		1	1	1***
Internal modem with gateway (ModemGate)		1	1	1***
HTML web page server		■	■	■
IRIG-B port (unmodulated IRIG B00x time format)		1	1	1
Modbus TCP Master / Slave (Ethernet port)		■ / ■	■ / ■	- / ■
Modbus RTU Master / Slave (Serial ports)		■ / ■	■ / ■	- / ■
DNP 3.0 through serial, modem, and I/R ports		■	■	■
DLMS COSEM through serial, Ethernet and optical ports for all variants		■	■	■

* With optional I/O Expander.

** For 9S, and 36S only. For 35S system up to 480 V L-L.

*** C model limited to IR + 2 other ports at one time. Ports can be enabled/disabled by user.



PowerLogic ION8650 front panel harmonic display.

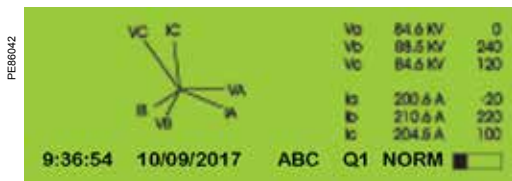

ION8650 front panel phasor display and table.

Electrical characteristics		
Type of measurement		True rms 1024 samples per cycle
Measurement accuracy	Current and voltage	0.1 % Reading
	Power	0.1 %
	Frequency	±0.001 Hz
	Power factor	0.1 %
Energy		0.1 %, twice as accurate as ANSI Class 0.2 and IEC 62053-22/23 (0,2S)
	Data update rate	0.5 cycle or 1 second (depending on value)
Input-voltage characteristics*	Nominal voltage	57 V to 277 V L-N rms 100 V to 480 V L-L rms (35S)
	Maximum voltage	347 V L-N rms, 600 V L-L rms (9S)
	Impedance	5 MΩ /phase (phase-Vref/Ground)
	Inputs	V1, V2, V3, VREF
Input-current characteristics	Rated nominal/current class	1A, 2 A, 5 A and/or 10 A (Class 1/2/10/20)
	Accuracy range	0.01 - 20 A (standard range)
	Measurement range	0.001 - 24 A
	Permissible overload	500 A rms for 1 second, non-recurring
Burden per phase		Socket: Typical: 3 W, 8 VA/phase, 3-phase operation; Maximum: 4 W, 11 VA/phase, 3-phase operation Switchboard: 0.05 V A at 1 A (0.05 Ω max)
	Standard power supply, blade powered	120-277 V L-N RMS (-15 %/+20 %) 47-63 Hz or 120-480 V L-L RMS (-15 %/+20 %) 47-63 Hz (35S)
Power supply	Auxiliary powered low voltage	AC: 65-120 (+/- 15 %) VLN RMS, 47-63 Hz DC: 80-160 (+/- 20 %) VDC
	Auxiliary powered high voltage	AC: 160-277 (+/- 20 %) V L-N RMS, 47-63 Hz DC: 200-300 (+/- 20 %) V DC
	Ride-through time, (Standard power supply)	Socket: min guaranteed: 6 cycles at nominal frequency (minimum 50 Hz), at 120 V L-N rms (208 V L-L rms) 3-phase operation Switchboard: min guaranteed: 6 cycles at nominal frequency (minimum 50 Hz), at 120 V L-N rms (208 V L-L rms) 3-phase operation
	Input/outputs**	Digital outputs
Digital inputs		upto 3 Self-excited, dry contact sensing inputs
Mechanical characteristics		
Weight		7.0 kg
IP degree of protection	Socket	Front IP65, back IP51
	Switchboard	Front IP50, back IP30
Dimensions	Socket	178 x 237 mm
	Switchboard	285 x 228 x 163 mm
Environmental conditions		
Operating temperature		-40 °C to 85 °C
Display operating range		-40 °C to 70 °C
Storage temperature		-40 °C to 85 °C
Humidity rating		5 % to 95 % RH non-condensing
Pollution degree		2
Installation category		Cat III
Dielectric withstand		2.5 kV
Electromagnetic compatibility		
Electrostatic discharge		IEC 61000-4-2
Immunity to radiated fields		IEC 61000-4-3
Immunity to fast transients		IEC 61000-4-4
Immunity to surge		IEC 61000-4-5
Immunity conducted		IEC 61000-4-6
Damped oscillatory waves immunity		IEC 61000-4-12
Conducted and radiated emissions		CISPR 22 (class B)
Safety		
Europe		As per IEC 62052-11
North America		As per ANSI C12.1

* Specifications are limited by the operating range of the power supply if a non-aux power supply is used.

** More input and output selections available via optional I/O expander.

PB117744



Example embedded webserver page (WebMeter) showing realtime values.

Communication

RS-232 / RS-485 port (COM1)	User-selectable RS-232 or RS-485. 300 - 115,200 baud (RS-485 limited to 57,600 bps); protocols: ION, Modbus/RTU/Mastering, DLMS, DNP 3.0, GPSTRUETIME/DATUM.
Internal modem port (COM2)	300-57,600 bps
ANSI 12.18 Type II optical port (COM3)	Up to 57,600 bps
RS-485 port (COM4)	Up to 57,600 baud, Modbus, direct connection to a PC or modem
Ethernet port	10/100BASE-T, RJ45 connector, protocols: DNP, ION, Modbus/TCP/Mastering, IEC 61850 Ed. 2 or 100BASE-FX multimode, male ST connectors, DLMS
EtherGate	Up to 31 slave devices via serial ports
ModemGate	Up to 31 slave devices

Firmware characteristics

High-speed data recording	Up to 1/2-cycle interval burst recording, stores detailed characteristics of disturbances or outages. Trigger recording by a user-defined setpoint, or from external equipment.
Harmonic distortion	Up to 63rd harmonic for all voltage and current inputs
Dip/swell detection	Analyse severity/potential impact of sags and swells: <ul style="list-style-type: none"> - magnitude and duration data suitable for plotting on voltage tolerance curves - per phase triggers for waveform recording or control operations
Instantaneous	High accuracy measurements with 1s or 1/2 cycle update rate for: <ul style="list-style-type: none"> - voltage and current - active power (kW) and reactive power (kVAR) - apparent power (kVA) - power factor and frequency - voltage and current unbalance - phase reversal
Load profiling	Channel assignments are user configurable: <ul style="list-style-type: none"> - 800 channels via 50 data recorders (feature set A), - 720 channels via 45 data recorders (feature set B), - 80 channels via 5 data recorders (feature set C). Configure for historical trend recording of energy, demand, voltage, current, power quality, other measured parameters. Recorders can trigger on time interval basis, calendar schedule, alarm/event condition, manually.
Waveform captures	Simultaneous capture of all voltage and current channels <ul style="list-style-type: none"> - sub-cycle disturbance capture (16 to 1024 samples/cycle)
Alarms	Threshold alarms: <ul style="list-style-type: none"> - adjustable pickup and dropout setpoints and time delays, numerous activation levels possible for a given type of alarm - user-defined priority levels - boolean combination of alarms
Advanced security	Up to 50 users with unique access rights. Perform resets, time syncs, or meter configurations based on user privileges.
Transformer correction	Correct for phase / magnitude inaccuracies in current transformers (CTs), potential transformers (PTs)
Memory	128 MB (A), 64 MB (B), 32 MB (C)
Firmware update	Update via the communication ports

Display characteristics

Type	FSTN transreflective LCD
Backlight	LED
Languages	English

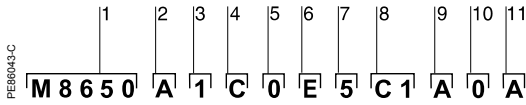

- 1 Model.
- 2 Feature set.
- 3 Form factor.
- 4 Current Inputs.
- 5 Voltage inputs.
- 6 Power supply.
- 7 System frequency.
- 8 Communications.
- 9 Input/output options.
- 10 Security.
- 11 Special order options.



PowerLogic ION8650 meter with switchboard case

Commercial reference numbers

Item	Code	Description
1 Model	M8650	Schneider Electric energy and power quality meter.
2 Feature Set	A	128 MB Memory Class A power quality analysis, waveforms and transient capture with 1024 samples/cycle.
	B	64 MB memory, energy meter Class S EN 50160 Ed. 4 power quality monitoring.
	C	32 MB memory, basic tariff/energy metering (5 data recorders, 80 channels).
3 Form Factor (1)	0	Form 9S/29S/36S Base, 57-277 V L-N (autoranging) 3-Element, 4-Wire / 2 1/2-Element, 4-Wire
	1	Form 35S Base - 120-480 V L-L (autoranging) 2-Element, 3-Wire
	4	Form 9/29/35/36S FT21 Switchboard (meter + case) with break out panel
	7	Form 9/29/35/36S FT21 Switchboard (meter + case) with break out cable
4 Current Inputs	C	1, 2 or 5 A nominal, 20 A full scale (24 A fault capture, start at 0.001 A)
5 Voltage Inputs	0	Standard (see Form Factor above)
6 Power Supply*	E	Form 9/29/35/36S, (socket) and Form 9, 36 (FT21 switchboard): 120-277 V AC. Form 35S (socket) and Form 35 (FT21 switchboard): 120-480 V AC. Powered from the meter's voltage connections.
	H	Auxiliary Power Pigtail: 65-120 V AC or 80-160 V DC (power from external source)
	J	Auxiliary Power Pigtail: 160-277 V AC or 200-300 V DC (power from external source)
	K	Auxiliary Power Pigtail: 65-120 V AC, 80-160 V DC (power from external source), Universal Socket Style
	L	Auxiliary Power Pigtail: 160-277 V AC, 200-350 V DC (power from external source), Universal Socket Style
7 System Frequency	5	Calibrated for 50 Hz systems.
	6	Calibrated for 60 Hz systems.
8 Communications	A 0	Infrared optical port, RS-232/RS-485 port, RS-485 port
	C 7	Infrared optical port, Ethernet (10/100BASE-T), RS-232/485 port, RS-485 port (note: in addition to infrared optical port, Feature Set C can use any two ports (configurable)), 56 k universal internal modem (RJ11)
	E 1	Infrared optical port, Ethernet (10/100BASE-T), RS 232/485 port, RS-485 port (note: in addition to infrared optical port, Feature Set C can use any two ports (configurable))
	F 1	Infrared Optical port, Ethernet (100BASE-FX multi-mode) with male ST connectors (available on socket meters only, Forms 0 & 1 above. I/O card not available if this option is ordered.) RS-232/485 port, RS-485 port (Note: in addition to Infrared Optical port Feature Set C can use any two ports (configurable))
	M 1	Infrared optical port, RS-232/485 port, RS-485 port (note: in addition to infrared optical port, Feature Set C can use any two ports (configurable)), 56 k universal internal modem (RJ11).
9 Onboard I/O	A	None.
	B	4 Form C digital outputs, 3 Form A digital inputs.
	C	4 Form C digital outputs, 1 Form A digital output, 1 digital input.
10 Security	0	Password protected no security lock.
	1	Password protected with security lock enabled
	3	RMICAN (Measurement Canada approved)
	4	RMICAN-SEAL (Measurement Canada approved, and factory sealed)
	7	Password protected, no security lock (US only)
	8	Password protected with security lock enabled (US only)
11 Special Order	A	None

*Specifications are limited by the operating range of the power supply if a non-aux power supply is used.

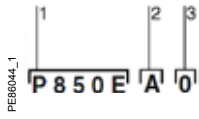

Example order code. Use this group of codes when ordering the I/O Expander.

- 1 Digital / Analogue I/O.
- 2 I/O option.
- 3 Cable option.



Commercial reference numbers (cont.)

I/O Expander		
Digital/Analogue I/O	P850E	Schneider Electric I/O Expander for ION8600 meters: Inputs and Outputs for energy pulsing, control, energy counting, status monitoring, and analogue interface to SCADA.
I/O option	A	External I/O box with 8 digital inputs and 8 digital outputs (4 Form A, 4 Form C)
	B	External I/O box with 8 digital inputs and 4 digital outputs (4 Form C) and 4 analogue outputs (0 to 20 mA)
	C	External I/O box with 8 digital inputs and 4 digital outputs (4 Form C) and 4 analogue outputs (-1 mA to 1 mA)
	D	External I/O box with 8 digital inputs and 4 digital outputs (4 Form C) and 4 analogue outputs (two -1 to 1 mA, and two 0 to 20 mA outputs)
Cable	0	No cable - cables for the I/O box are no ordered as a separate part number. Refer to commercial reference numbers: CBL-8X00IOE5FT, CBL-8X00IOE15FT and CBL-8XX0-BOP-IOBOX under Connector cables, below.

Comm. ref. no.	A-base adapters
A-BASE-ADAPTER-9	Form 9S to Form 9A adapter
A-BASE-ADAPTER-35	Form 35S to Form 35A adapter
	Optical communication interface
OPTICAL-PROBE	Optical communication interface
	Connector cables
CBL-8X00BRKOUT	1.5 m extension cable, mates with 24-pin male Molex connector from the meter to the 24-pin Molex connector on the I/O expander box (not for use with breakout panel E8, F8 & G8 form factors)
CBL-8X00IOE5FT	44.57 m extension cable, mates with 24-pin male Molex connector from the meter to the 24-pin Molex connector on the I/O expander box (not for use with breakout panel E8, F8 & G8 form factors)
CBL-8X00IOE15FT	44.57 m extension cable, mates with 24-pin male Molex connector from the meter to the 24-pin female Molex connector on the I/O Expander box (not for use with breakout panel E8, F8 & G8 form factors)
CBL-8XX0-BOP-IOBOX	1.8 m connector cable, 24-pin male to 14-pin male Molex connector for connecting an ION8000 Series meter with breakout panel to an I/O Expander Box

ION8650 socket dimensions

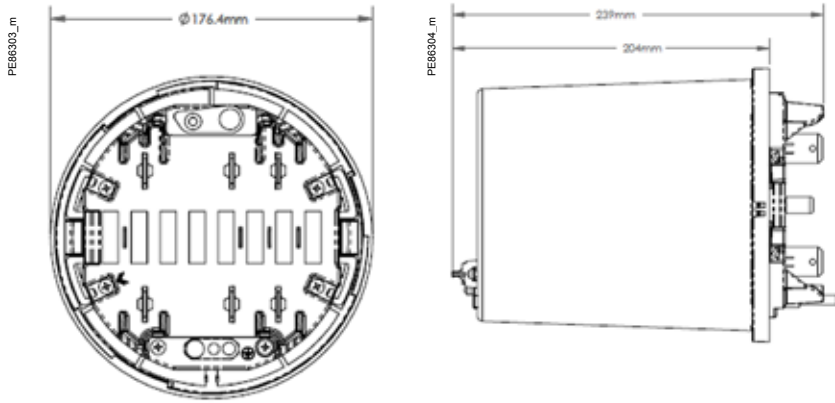

ION8650 switchboard dimensions

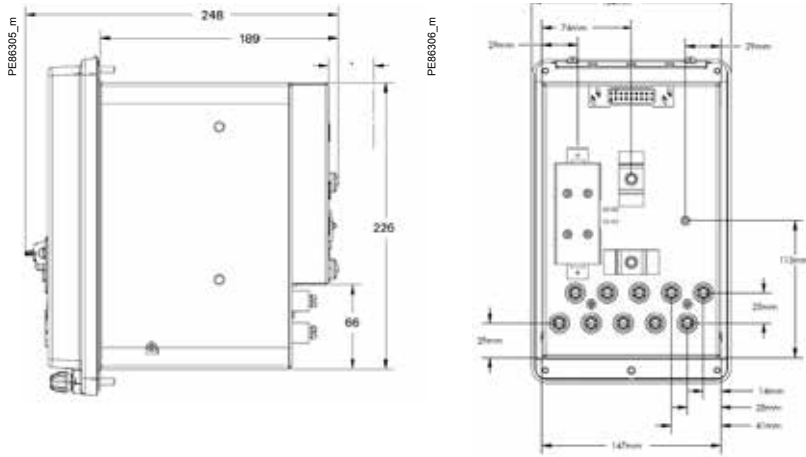

I/O Expander dimensions

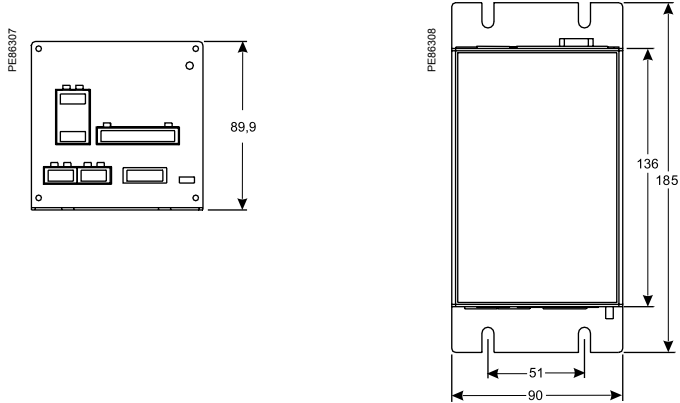

ION8650 suggested switchboard mounting dimensions

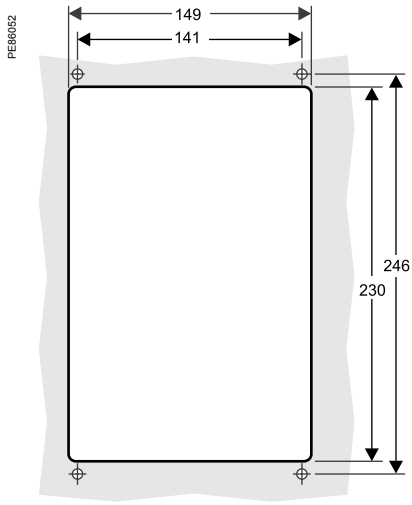

ION8650 switchboard mounting

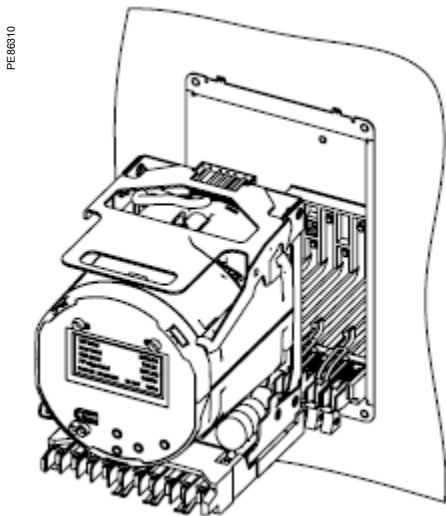
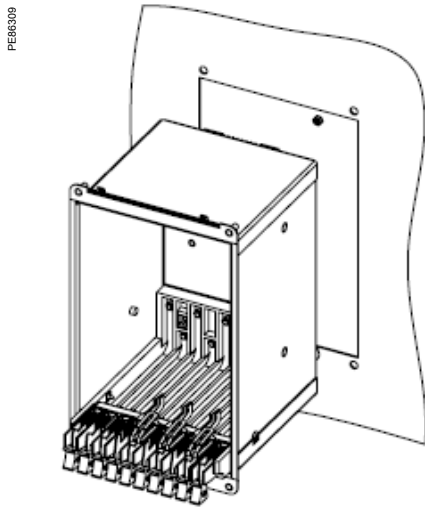

Please see appropriate Installation Guide for these products for further details.

Schneider Electric Industries SAS
35, Rue Joseph Monier,
CS 30323
F - 92506 Rueil Malmaison Cedex

RCS Nanterre 954 503 439
Capital social 896 313 776
www.schneider-electric.com

ION8650 Series
PLSED310027EN

As standards, specifications and designs develop from time to time, please ask for confirmation of the information given in this document.

Design: Schneider Electric
Photos: Schneider Electric

Over 75 % of Schneider Electric products
have been awarded the Green Premium ecolabel



© 2018 - Schneider Electric - All rights reserved

05-2018

Life Is On

Schneider
Electric