

Budgetary Design / Build Services

For

75kW, 208V All-In-One – Reference Design #10

Proposal # MCS-REF-10

Provided By
Schneider Electric IT Mission Critical Services, Inc.
3975 Fair Ridge Drive, Suite 210S
Fairfax, VA 22033



Pricing Valid for 30 Days



TABLE OF CONTENTS

PART I - INTRODUCTION2

- A. Solution Overview 2
- B. Solution Benefits..... 2
- C. Proposed Schedule 2

PART II - SCOPE OF WORK3

- A. Proposed Layouts 3
 - 1. Exterior Renderings..... 3
 - 2. Interior Renderings 4
- B. General Construction..... 5
- C. Mechanical, Electrical, Plumbing (MEP) Design and Concept 5
 - 1. Mechanical Approach 5
 - Proposed Mechanical Equipment..... 5
 - 2. Electrical Approach 6
 - Proposed Electrical Equipment..... 6
- D. Fire Protection 7
- E. Building Management System 7
- F. Commissioning 7
- G. Equipment Delivery 8
- H. Engineering Approach 8
- I. Project Management Approach..... 9

PART III – QUALIFICATIONS AND EXCLUSIONS.....10

PART IV – BUDGETARY PRICING.....12



PART I: INTRODUCTION

A. SOLUTION OVERVIEW

Schneider Electric IT Mission Critical Services, Inc. ("Schneider MCS") is providing this 75kW, 208V All-In-One (AIO) ISO Container as a reference design to show an actual turn-key cost for installing this complete solution. Pricing can vary based on labor rates, site conditions and other variables. This turn-key proposal pricing has been calculated based on being installed in St. Louis, MO on a level/cleared lot that is pad ready. The proposed data center solution shall contain twelve (12) racks supported by seven (7) Bard wall-mounted cooling units, one (1) Symmetra PX100 UPS system and one (1) optional 250kW, 208V stand-by generator. A new customer provided utility transformer will need to be installed within 50' of the proposed location of the prefabricated data center. Schneider Electric will set the All In One module and the optional stand-by generator on a new concrete pad.

B. SOLUTION BENEFITS

Schneider MCS has developed a reference design that is reliable, efficient, and cost effective.

- ✓ Offers more flexibility with an alternative construction option for building or expanding data centers
- ✓ Allows for easy deployment in remote areas, warehouses, or other areas not designed for data centers
- ✓ Reduces project complexity, simplifies site coordination, and minimizes project changes and delays
- ✓ Provides a more predictable solution with the cost, density, availability, and efficiency as designed and promised
- ✓ Improves reliability with a solution that is assembled and tested in a factory environment

C. PROPOSED SCHEDULE

Schneider MCS will develop a full schedule once under contract. This schedule will allow for the design team to determine long lead items far in advance of completion of final construction documents. The construction team can order long lead items in advance if required, which can potentially shorten the project schedule.

A. PROPOSED LAYOUTS

1. Conceptual Exterior Module Renderings

Exterior Front View

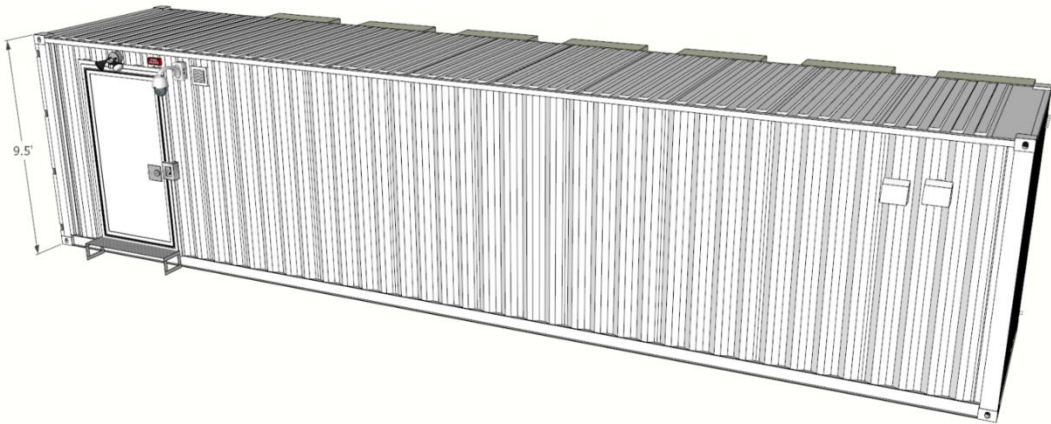

Exterior Rear View

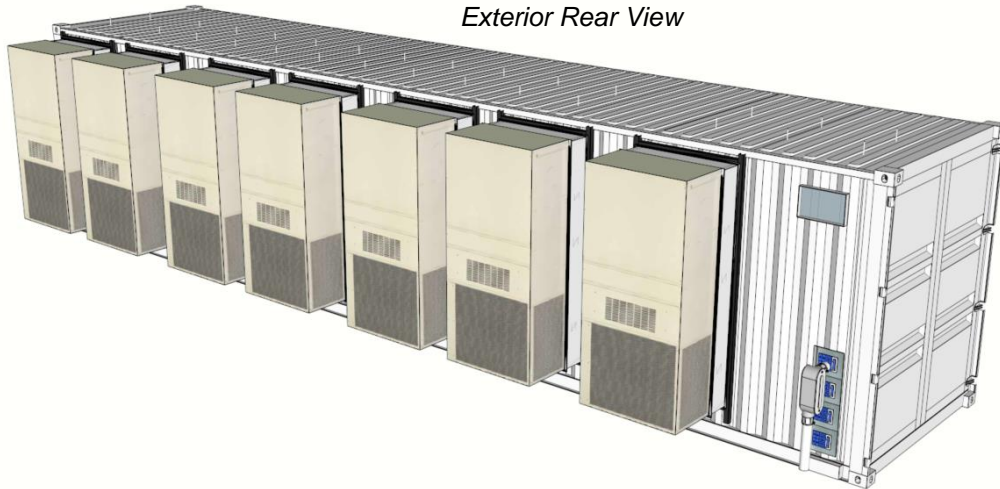

Exterior View with Dimensions

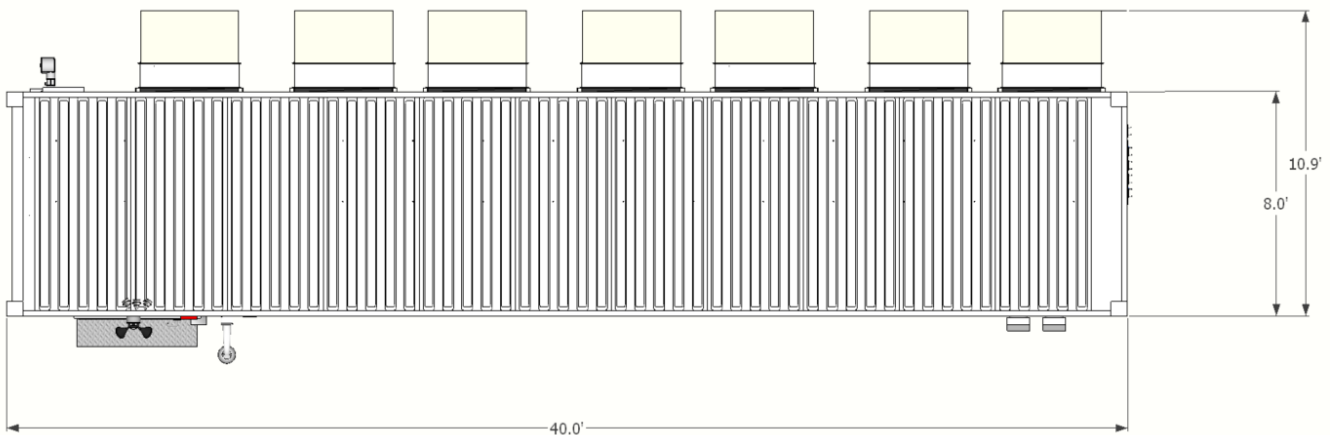

2. Conceptual Interior Module Renderings

Interior Side View

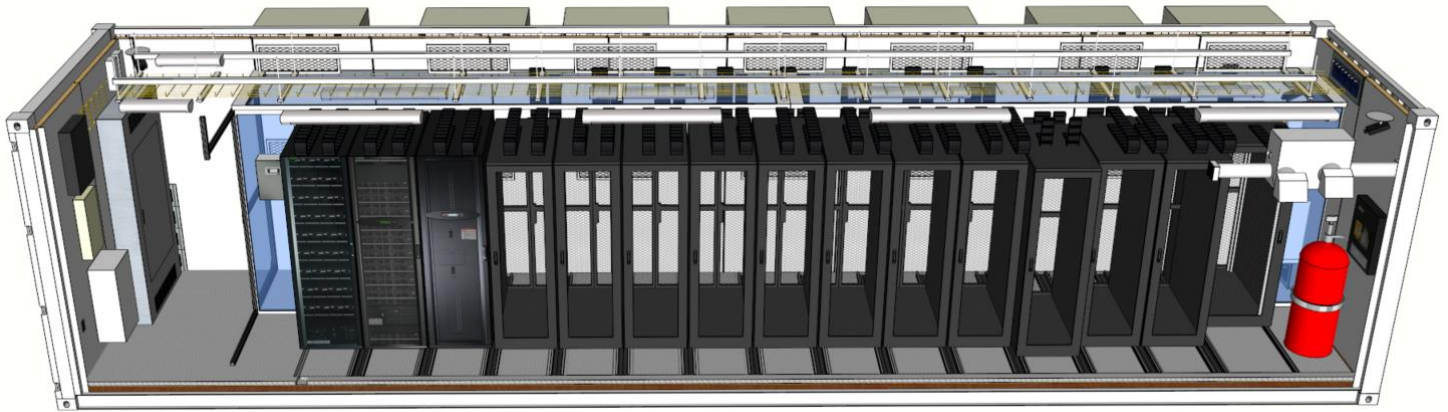

Interior Overhead View

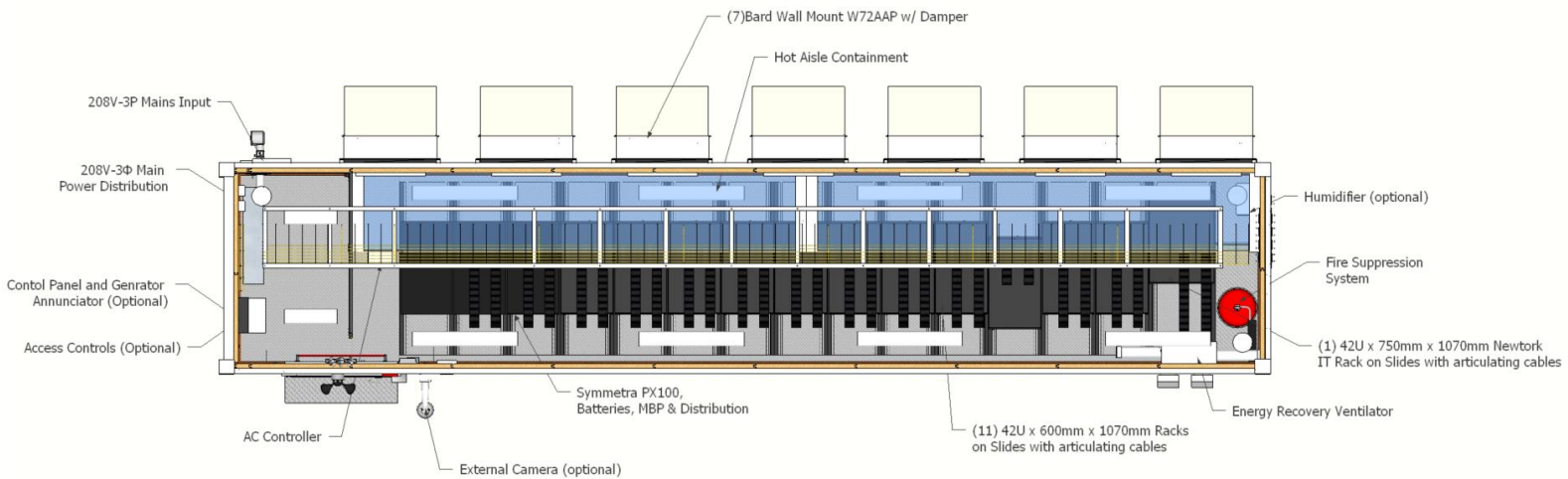



B. GENERAL CONSTRUCTION SCOPE

Schneider MCS will act as General Contractor and provide all building trade associated work. SOW details are as follows:

1. Pre-Construction:

- a. Geotechnical / Site Survey
- b. Mobilization
 - i. Site trailers
 - ii. Port-o-johns
 - iii. Temporary entrance
 - iv. Temporary utility

2. Job Conditions:

- a. Project management and supervision
- b. Jobsite cleanup and trash removal
- c. General liability insurance
- d. Final cleaning
- e. Permit Fees

3. Earthwork:

- a. Site grading – Assumed to require minimal earthwork and is close to “pad” ready
- b. Site utilities – Assumed to be within 50’ of the AIO module

4. Concrete Work:

- a. Form and pour new concrete equipment pad. Pad is not to exceed 33.5 yds³
- b. Form and pour new optional concrete generator pad. Pad not to exceed 8.5 yds³
Concrete pads to include:
 - i. 12” min depth pad reinforced with #4 rebar @ 12” on center top and bottom
 - ii. 4000 PSI concrete
 - iii. Subgrade with 4” min. crushed stone base
 - iv. 18” footer around perimeter
 - v. NOTE: we have not assumed any soil stabilization or deep foundations

5. Metals:

- a. Stairs / railings

C. MECHANICAL AND ELECTRICAL DESIGN AND CONCEPT

Schneider MCS’ proposed Reference Design #10 will be a 75kW, 208V AIO Module with N+1 redundancy mechanically. The Mechanical and Electrical design are detailed below.

1. **Mechanical Design:** Schneider MCS shall provide seven (7) wall-mounted cooling units with dampers and reheat that will serve to cool the AIO module. Dehumidification control shall be provided. One (1) wall-mounted humidifier is available as an option.

Mechanical Equipment List

1. Seven (7) Bard W72 wall-mounted units with dampers and reheat.
2. **Optional** Wall-mounted humidifier

1. **Electrical Design:** Schneider MCS has designed an electrical distribution system to serve the AIO module. This system includes a UPS, ATS, Panelboard, and an optional Stand-by Generator. Due to the narrow width of the ISO container each component of the row will be placed on a sliding track system and flexible cable tray to allow for equipment maintenance, and to provide flexibility for working depth adjustment on the front and rear side of the racks as required.

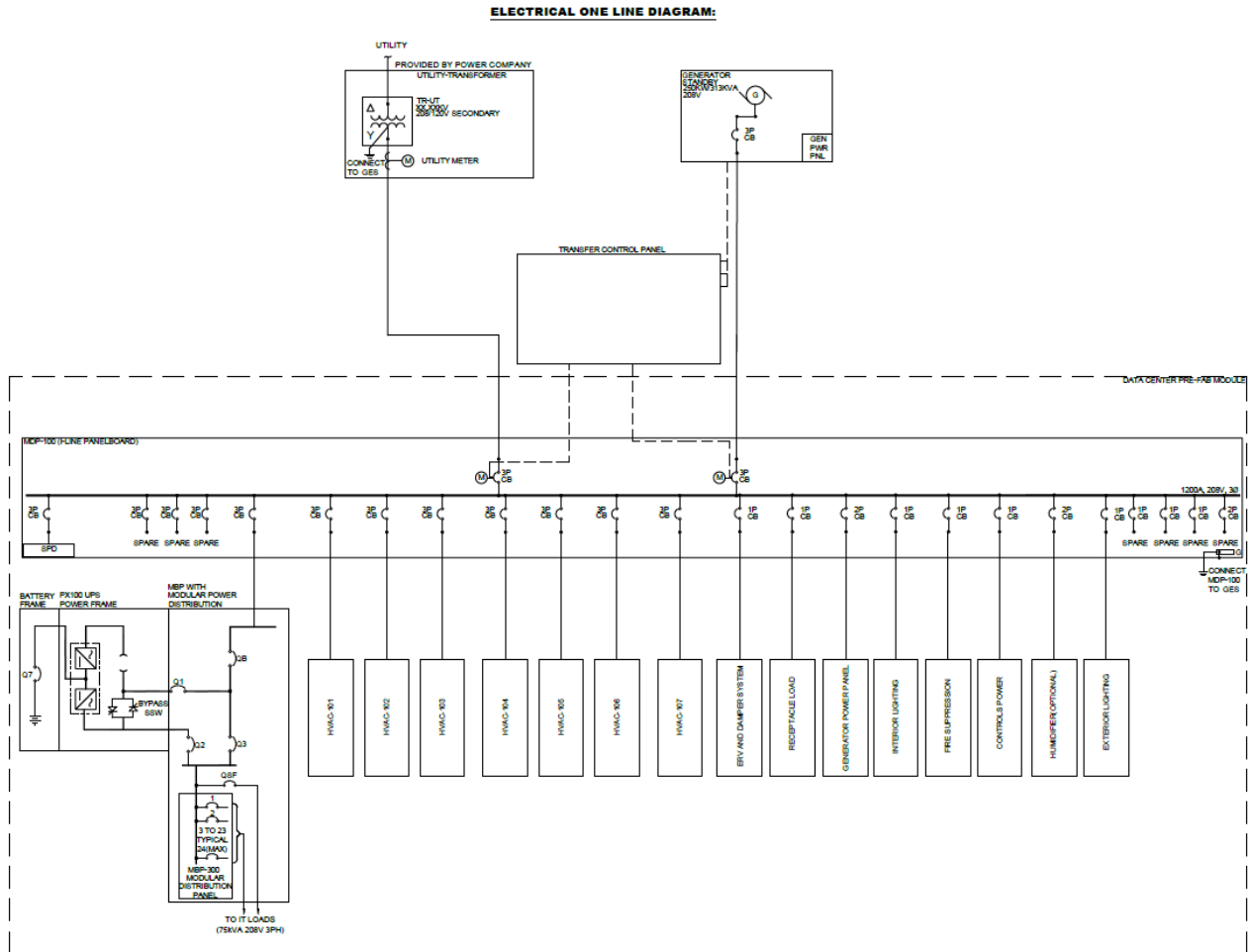

*Proposed Electrical Single-Line **Drawing E400***

Electrical Equipment List

1. One (1) Symmetra PX100 UPS
2. One (1) Modular Power Distribution Unit
3. Eleven (11) AR3100 42U Server Racks 600mm x 1070mm
4. One (1) AR3150 42U Server Rack 750mm x 1070mm
5. Twelve (12) AP8865 Metered Rack PDU 8.6kW, 208V
6. One (1) CP-100 Transfer Control Panel
7. One (1) I-Line 800A Panelboard
8. Lightning Protection
9. Grounding
10. **Optional** 250W, 208V, Stand-by Generator

D. FIRE PROTECTION

Fire Suppression

Schneider MCS will provide and install a Novec 1230 Fire Suppression system for the Electrical Rooms. SOW details are as follows:

1. Design, furnish and install a Novec 1230 System to include the following items:
 - a. Cylinders with Liquid Level Indicators
 - b. Designed LBS of Agent
 - c. Control Panel with Battery Backup
 - d. Control Head
 - e. Designed quantity of Ceiling Detectors (Sniffers)
 - f. Release Station
 - g. Abort Station
 - h. Horn/Strobes
 - i. Strobe
 - j. Maintenance By-Pass Switch
 - k. All Pipe and Fittings
 - l. End User Training
 - m. Checkout Testing
 - n. O & M Manuals

E. BUILDING MANAGEMENT SYSTEM

Base offering includes the following systems. Complete Building Monitoring System can be quoted upon request.

1. One (1) NetBotz Rack Monitoring System
2. One (1) EcoStruxure IT Expert

F. COMMISSIONING

Schneider MCS intends to provide oversight to our 3rd party Commissioning Agent who will perform the following levels of testing within the contract:

1. **Individual System Operation Site Test:** Site acceptance testing of the individual systems is performed following start-up and commissioning of the system by the contractor, the manufacturer's factory representatives and the vendor.
2. **Integrated Systems Testing:** Simulated operation of the entire system is performed including simulated failures, unexpected events, and sequential changes to the operating equipment.

The following documentation will be developed as part of the testing deliverables to the Customer:

1. Commissioning Plan for use during all design and construction activities.
2. Deficiencies Log.
3. Level 4/5 Functional Acceptance Testing documents.
4. Final reports and recommendations.

Qualifications and Exclusions specific to Commissioning:

1. LEED or enhanced commissioning services are not included.

2. Fire system testing and demonstration for authority having jurisdiction to be provided by others. Our scope includes observation of such testing and sequence verification of HVAC equipment.
3. Thermo graphic (IR) summary WILL NOT be issued and/or included in our executive summary unless anomalies are found during the IR scans at time of commissioning. If anomalies are found, a final summary will include pictures of discrepancy, along with description and location of associated component/components in question.
4. Documentation and witness of start-up procedures.
5. Factory Witness Testing.

G. EQUIPMENT AND RIGGING DELIVERY

Schneider MCS will be responsible for delivery of all equipment to the site, offloading equipment, and setting in place.

1. Upon coordination with the Project Manager the equipment will be delivered to the Customer's facility.
2. Schneider MCS will provide labor and tools to off-load the equipment on site.
3. Schneider MCS will provide all required rigging equipment to set in place the 75kW AIO and associated wall-mounted cooling units and optional generator.
4. Remove all crating and shipping materials from the site.

H. ENGINEERING

Schneider MCS will provide electrical, mechanical and structural engineering services for the design and installation services for the prefabricated module. The following engineering and design tasks are based upon the assumption that the end user can provide existing civil engineering documents as well as any as-built drawings if applicable pertaining to electrical, mechanical, structural, etc.

Schneider MCS Mechanical Engineering team will:

1. Perform mechanical calculations and designs to ensure the proper operation of the new system.
2. Design a properly sized condensate piping system.

Schneider MCS' Electrical Engineering will consist of designs for power for the prefabricated module. The electrical infrastructure will be designed to support the full growth. Electrical distribution will be designed to accommodate the cooling system as described in the mechanical engineering description above.

Perform electrical calculations and designs to support the required prefabricated module connected load for the UPS systems and power distribution units. This system will be capable of carrying the full load of the module.

1. Design electrical riser to include the following:
 - a. Electrical risers from the customer connection point.
 - b. UPS/Power and IT module input feeders.
 - c. Power distribution related to designed IT load.
 - d. Electrical distribution for racks.
 - e. Electrical feeders related to the cooling system as described in the mechanical engineering description above.
2. Load calculations for connections to the customer connection point.
3. Provide proper electrical equipment lay out for UPS equipment, battery cabinets, power distribution units, etc.



The following drawings and documents will be furnished as part of this project:

1. Floor layout indicating equipment layout
2. Mechanical design for cooling system
3. Electrical riser
4. Fire Suppression drawings

5. Civil design for site prep

Schneider MCS will distribute approved engineered drawings for the Customer review and provide As-Built drawings upon completion of the project in CAD, PDF and hard copy formats.

Arc Flash and Breaker Coordination Study

1. Perform Arc Flash and Breaker Coordination study starting at the customer connection point for this solution down to the rack level.
 - a. Install Arc Flash stickers as required per the study. (Arc Flash study is currently valid up to three years OR when changes are made. It is the customer's responsibility to ensure that the Arc Flash study is performed per code after initial Arc Flash study has been completed.)
 - b. Breaker Coordination studies are performed to ensure that breakers trip as per the engineering design. This protects the equipment and personnel. This is performed at the same time as the Arc Flash study.

Construction Administration Phase to be performed during the construction project

1. Review submittals and shop drawings.
2. Incorporate comments from the permit plans reviewers as required.
3. Review final testing reports for all electrical systems.
4. Provide on-site engineering to perform as-built field verification. The as-built field verification will be performed in addition to the red line drawings provided by the installing contractor.

I. PROJECT MANAGEMENT

The Design / Build team at Schneider MCS is comprised of professionals that have knowledge and experience in executing mission critical projects. Schneider MCS' execution process provides a trusted single point-of-contact, backed by a complete team for site design and planning.

Examples of key project activities include: Requests for Information ("RFI"), Submittals, Change Orders, Subcontracts, Construction Meetings (Schedule & Budget Reviews) and Contract Closeout.

Schneider MCS will implement a two (2) man team consisting of a Project Manager and On-site Superintendent/Project engineer for an estimated duration of 2.5 months.

Internal MCS personnel involved include but are not limited to the following:

- Project Manager
- Site Superintendent
- Project Engineer
- MEP Engineer
- Project Support Staff (Pre-Construction, Business Capture, Contracts, Project Accounting)



PART III: QUALIFICATIONS AND EXCLUSIONS

A. QUALIFICATIONS

1. This proposal is provided for budgetary purposes and is not to be used for contract or construction.
2. It is assumed that the customer is providing the Utility Transformer and that they will be installed within 50' of the main input of the ISO container.
3. If optional generator is selected, it is assumed that it would be installed within 50' of the main input of the ISO container.
4. If optional humidification is selected, it is assumed that the customer will provide a domestic water source within 50' of the main water connection of the ISO container.
5. Depending upon the location the actual IT capacity could be lower due to derating for altitude and ambient temperature.
6. Will connect any equipment drain line to an existing site drain location within 5' of the pad.
7. Fire Suppression System remote disconnecting control scheme per NEC 645.10.
8. A 2% permit fee allowance is included.
9. Module pricing subject to local and state building requirements.
10. Assumption is made that existing civil drawings will be provided by customer.
11. Daily clean-up shall be enforced throughout the duration of the project.
12. All work will be performed during normal business hours, Monday – Friday except for scheduled power outage if required.
13. Architectural and engineered drawings are included.
14. MEP engineered drawings included.
15. Lead times are contingent upon approved submittals.
16. Pricing assumes that this is a pad-ready site and minimal site work is included in pricing.
17. As-built drawings at the completion of the project are included.
18. Some engineering review meetings may take place remotely by Skype.
19. Schneider MCS and all subcontractors shall have access to site for duration of project.
20. It is assumed that the site is easily accessible for delivery and rigging of equipment without additional site modifications.
21. Schneider MCS plans to provide an onsite office trailer, port-o-lets, and open top trash container. Schneider MCS shall coordinate a location for these with the Customer once under contract.
22. Freight allowance included on all equipment based upon shipping to St. Louis.
23. If Site Security is required, it is to be provided by customer at no cost to Schneider MCS.
24. Once a reference design has been selected a site specific engineering solution will be developed taking into account changes in distances, materials, systems, etc. A new price will be provided based upon the site-specific engineering solution.
25. Rigging is based upon the site being accessible for the crane without site modifications. It is assumed that the crane set-up location is fairly level and suitable for supporting the weight of the crane and associated equipment. The crane sizing is based upon the weight of the module along with a lifting turning radius of 15'. Lifting under power/communication lines, over existing structures such as buildings, trees, etc. is not included in this pricing. Crane is only estimated for a single day.
26. Pad scope listed above is estimated based on typical sites. The Geotechnical survey may require different specifications for the pad once completed which could result in additional costs.
27. Arc flash coordination study consists of connection point downstream to the rack level.
28. Optional generator MUST be installed at the same time as the main solution or additional costs will be added to cover multiple deployments.
29. Standard 5 x 8 start-up services included at customer site.
30. Fuel provided for 4-hour load bank testing only.

B. EXCLUSIONS

1. Site drainage designs and installations.
2. Flood planning or reviews.
3. Noise level testing.
4. Meetings with architectural review boards.
5. Landscaping.
6. New utility transformer
7. Schneider MCS is not responsible for resolving any nonconformance and / or deficiency issues with the site or existing systems if applicable.
8. Location specific building code compliance and/or submittal is not included such as title 24, title 25, etc.
9. Structural Engineering to achieve required seismic rating.
10. Bond fees.
11. Adding the proposed equipment to an existing BMS system.
12. Alterations and modifications of the following existing "building systems" if applicable:
 - a. Fire alarm.
 - b. Fire suppression / Fire protection (Other than that described in Part I above).
 - c. Building Management System (HVAC automation controls).
 - d. Security / Access controls (Other than that described in Part I above).
 - e. Core facilities.
13. Security system designs and installations.
14. Bollards.
15. Fencing.
16. Dehumidification.
17. Factory witness testing.
18. Work on holidays, evenings or weekends.
19. All EPA fees associated with installation of diesel fuel tanks.
20. Fuel storage permits.
21. Network infrastructure cabling designs and installations.
22. Acoustical analysis.



PART IV: BUDGETARY PRICING

Description as set forth in Sections I – III above	Budgetary Price
SE Equipment and Integration	
Generator	
Electrical Installation	
Mechanical Installation	
Rigging	
Equipment Pads, Steps & Railings	
Project Management and General Conditions	
Engineering	
Commissioning	
Freight Allowance based on St. Louis, MO (Actual Freight TBD Based on Project Location)	
2 % Permit Allowance	
State Certification Program	
Budgetary Total:	

Pricing available upon request.