

BOTTOM VIEW

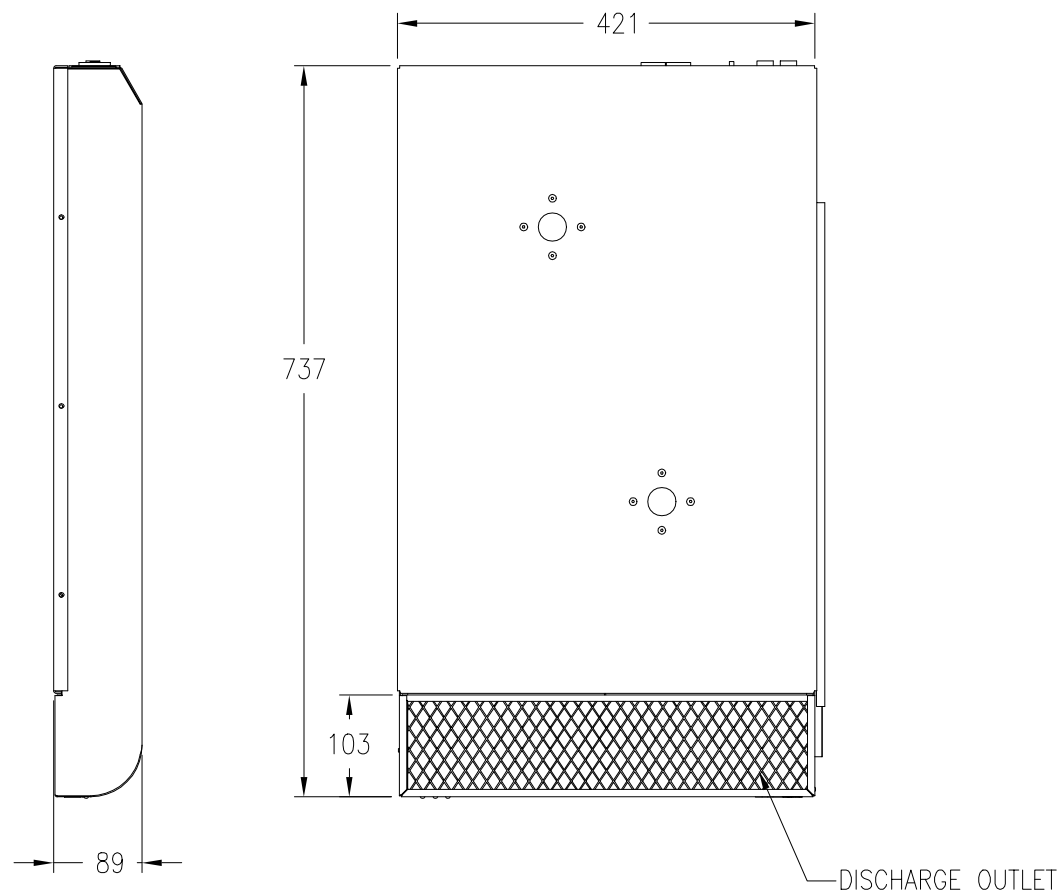

SIDE VIEW

TOP VIEW

NOTES:

1. ALL DIMENSIONS ARE IN MILLIMETERS
2. NET WEIGHT OF UNIT IS 19kg
3. AIRFLOW:
 - NON-RAISED FLOOR – 579 m³/h
 - RAISED FLOOR – 714 m³/h (WHEN INSTALLED OVER STANDARD RAISED FLOOR @ 16.9 mbar.)
4. INSTALLATION MUST COMPLY WITH NATIONAL AND LOCAL ELECTRICAL REGULATIONS.

THIS DRAWING AND SPECIFICATIONS HEREIN ARE THE PROPERTY OF AMERICAN POWER CONVERSION AND SHALL NOT BE COPIED, REPRODUCED OR USED IN WHOLE OR IN PART, AS THE BASIS FOR THE MANUFACTURE OR SALE OF ITEMS WITHOUT WRITTEN PERMISSION FROM APC. THIS DRAWING IS BASED UPON LATEST AVAILABLE INFORMATION AND IS SUBJECT TO CHANGE WITHOUT NOTICE.

TITLE: NetworkAir Product AIR DISTRIBUTION UNIT 230V, 50Hz		DWG NO: ACF002 – MM		REV. –
DRAWN BY: NAGENDRAK		09/10/03		PROJECTION
CHECKED BY: CLARSEN		29/10/03		
PROJECT: SUBMITTAL DRAWING		ENGINEER: B.STEINBERG		
SHEET 1 OF 2		29/10/03		



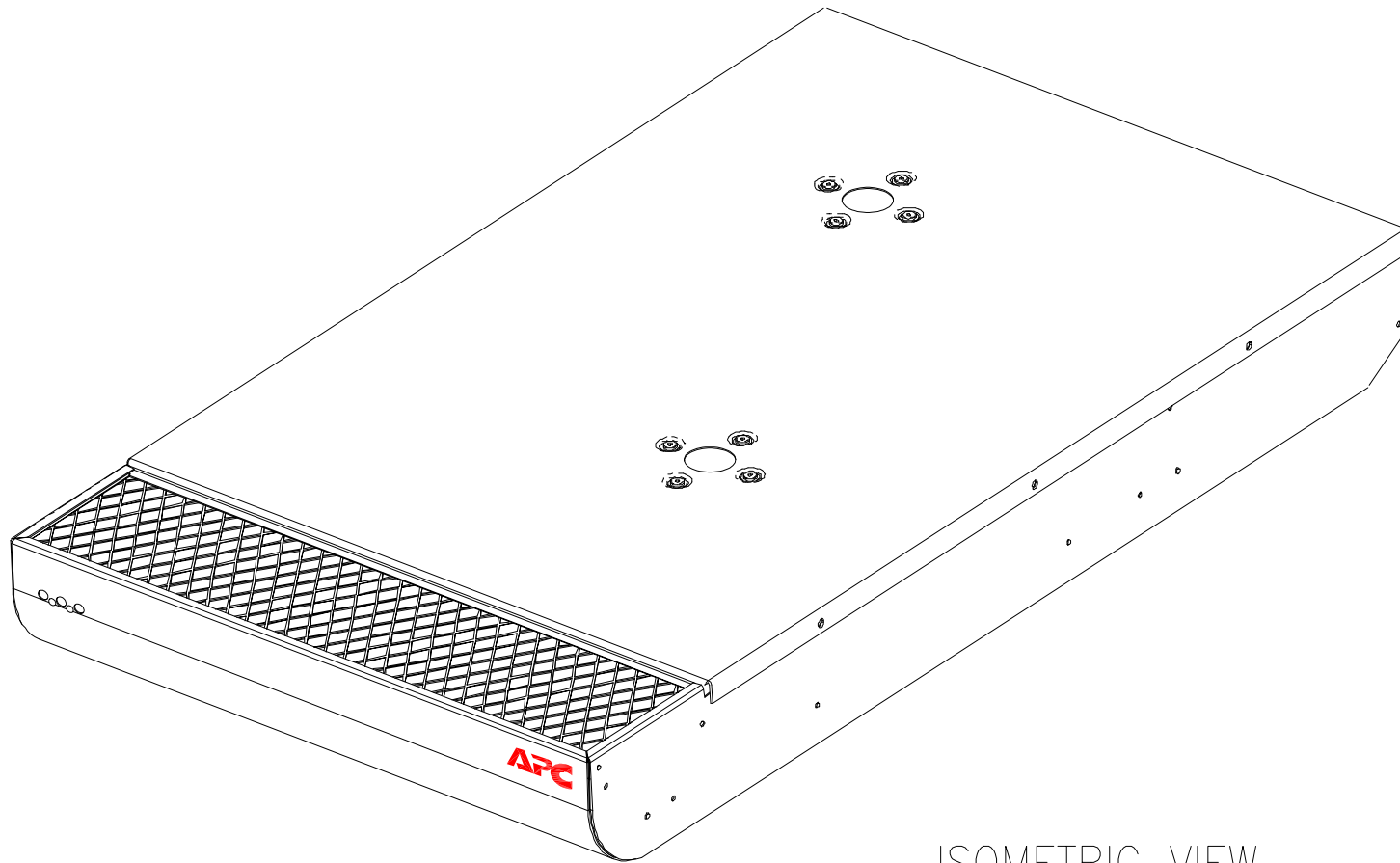

ISOMETRIC VIEW

THIS DRAWING AND SPECIFICATIONS HEREIN ARE THE PROPERTY OF AMERICAN POWER CONVERSION AND SHALL NOT BE COPIED, REPRODUCED OR USED IN WHOLE OR IN PART, AS THE BASIS FOR THE MANUFACTURE OR SALE OF ITEMS WITHOUT WRITTEN PERMISSION FROM APC. THIS DRAWING IS BASED UPON LATEST AVAILABLE INFORMATION AND IS SUBJECT TO CHANGE WITHOUT NOTICE.

TITLE: NetworkAir Product
AIR DISTRIBUTION UNIT
230V, 50Hz

DWG NO: ACF002 - ISO
REV. -
DRAWN BY: NAGENDRAK 09/10/03
CHECKED BY: C.LARSEN 29/10/03
ENGINEER: B.STEINBERG 29/10/03

PROJECTION

APC[®]
AMERICAN POWER CONVERSION
132 FARBGROUNDS RD
WEST KINGSTON, RI 02892

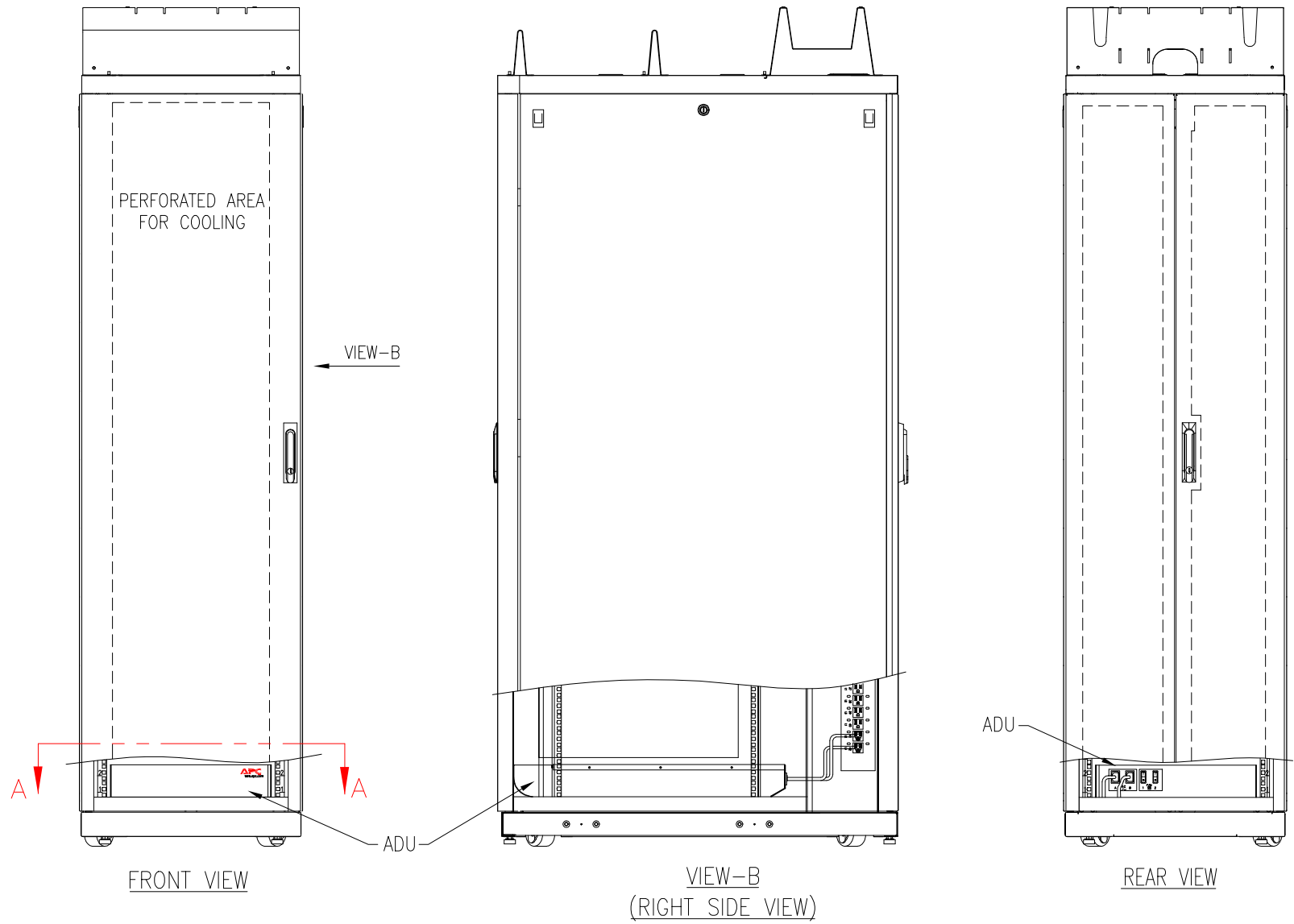

NOTE:

1. PLEASE REFER TO INSTALLATION MANUAL
2. INSTALLATION IS TYPICAL FOR ALL 600mm WIDE UNITS
3. SOME STRUCTURAL DETAILS HAVE BEEN OMITTED FOR CLARITY
4. INSTALLATION MUST COMPLY WITH ALL APPLICABLE NATIONAL AND LOCAL ELECTRICAL REGULATIONS.

<small>THIS DRAWING AND SPECIFICATIONS HEREIN ARE THE PROPERTY OF AMERICAN POWER CONVERSION AND SHALL NOT BE COPIED, REPRODUCED OR USED IN WHOLE OR IN PART, AS THE BASIS FOR THE MANUFACTURE OR SALE OF ITEMS WITHOUT WRITTEN PERMISSION FROM APC. THIS DRAWING IS BASED UPON LATEST AVAILABLE INFORMATION AND IS SUBJECT TO CHANGE WITHOUT NOTICE.</small>		TITLE: NETSHELTER VX 42U ENCLOSURE 600mm W X 1070mm D, BASE UNIT WITH AIR DISTRIBUTION UNIT INSTALLED		DWG NO: NSH-2100VX+ACF002-MM1		REV. -	
		PROJECT: SUBMITTAL DRAWINGS		SHEET 1 OF 3		ENGINEER: B.STEINBERG	
		DRAWN BY: E.DICHENKO		CHECKED BY: C.LARSEN		PROJECTION	
				10/10/03		30/10/03	
				30/10/03			
				<small>AMERICAN POWER CONVERSION 132 FAIRGROUNDS RD WEST KINGSTON, RI 02892</small>			

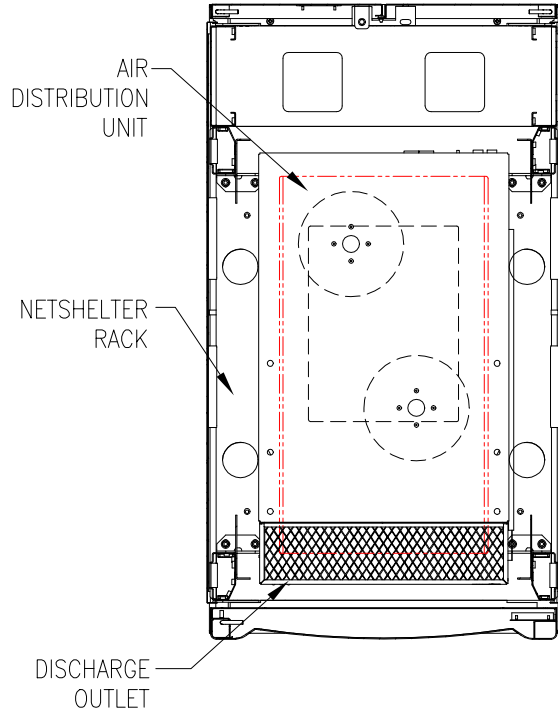

SECTION A-A (ENLARGED)
VIEW FROM INSIDE CABINET, LOOKING DOWN
(FILTER NOT SHOWN FOR CLARITY)

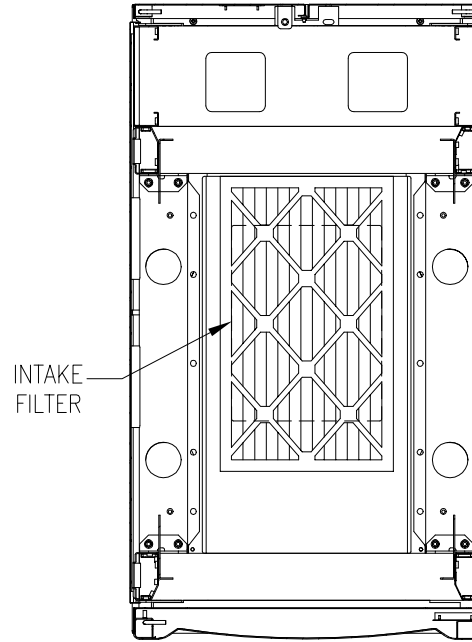

SECTION A-A (ENLARGED)
VIEW FROM INSIDE CABINET, LOOKING DOWN
(ADU NOT SHOWN)

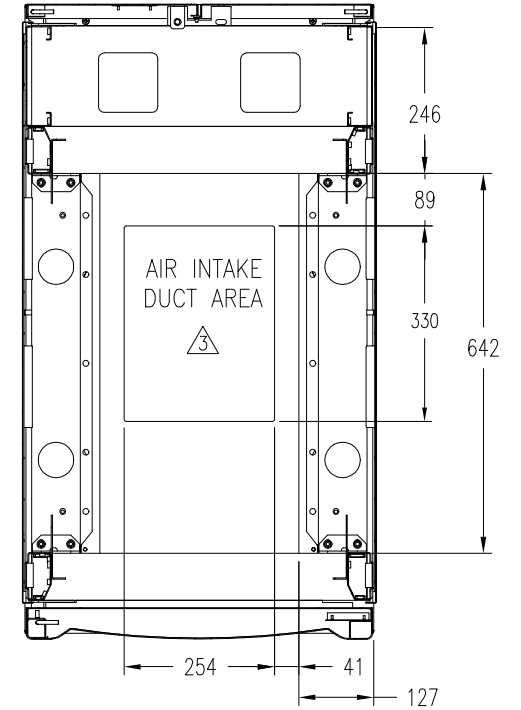

SECTION A-A (ENLARGED)
VIEW FROM INSIDE CABINET, LOOKING DOWN
(ADU AND FILTER NOT SHOWN)

NOTE:

1. PLEASE REFER TO INSTALLATION MANUAL
2. ALL DIMENSIONS ARE IN MILLIMETERS.
- △ 3. AIR INTAKE DUCT IS SHOWN AND USED FOR RAISED FLOOR APPLICATIONS ONLY
4. SOME STRUCTURAL DETAILS IN THESE SECTION VIEWS HAVE BEEN OMITTED FOR CLARITY
5. INSTALLATION MUST COMPLY WITH NATIONAL AND LOCAL ELECTRICAL REGULATIONS.

THIS DRAWING AND SPECIFICATIONS HEREIN ARE THE PROPERTY OF AMERICAN POWER CONVERSION AND SHALL NOT BE COPIED, REPRODUCED OR USED IN WHOLE OR IN PART, AS THE BASIS FOR THE MANUFACTURE OR SALE OF ITEMS WITHOUT WRITTEN PERMISSION FROM APC. THIS DRAWING IS BASED UPON LATEST AVAILABLE INFORMATION AND IS SUBJECT TO CHANGE WITHOUT NOTICE.

TITLE: NETSHELTER vx 42U ENCLOSURE
600mm W X 1070mm D, BASE UNIT
WITH AIR DISTRIBUTION UNIT INSTALLED

DWG NO: NSH-2100VX+ACF002-MM2
DRAWN BY: E.DICHENKO 10/10/03
CHECKED BY: C.LARSEN 30/10/03
ENGINEER: B.STEINBERG 30/10/03

REV. -
PROJECTION

APC[®]
AMERICAN POWER CONVERSION
132 FAIRGROUNDS RD
WEST KINGSTON, RI 02892

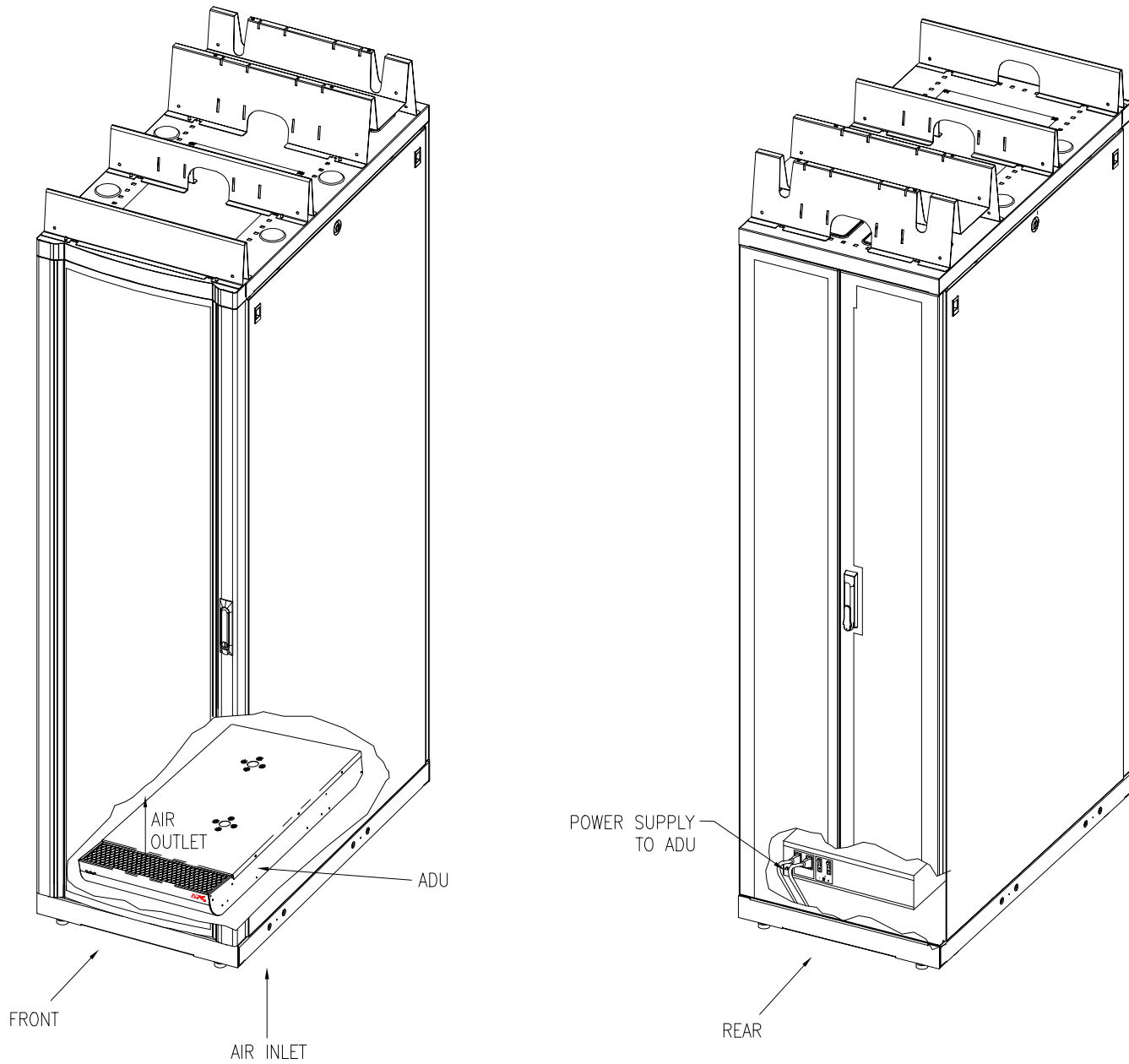

ISOMETRIC VIEW

NOTE:

1. SOME STRUCTURAL DETAILS HAVE BEEN OMITTED FOR CLARITY

<small>THIS DRAWING AND SPECIFICATIONS HEREIN ARE THE PROPERTY OF AMERICAN POWER CONVERSION AND SHALL NOT BE COPIED, REPRODUCED OR USED IN WHOLE OR IN PART, AS THE BASIS FOR THE MANUFACTURE OR SALE OF ITEMS WITHOUT WRITTEN PERMISSION FROM APC. THIS DRAWING IS BASED UPON LATEST AVAILABLE INFORMATION AND IS SUBJECT TO CHANGE WITHOUT NOTICE.</small>	TITLE: NETSHELTER VX 42U ENCLOSURE 600mm W X 1070mm D, BASE UNIT WITH AIR DISTRIBUTION UNIT INSTALLED		DWG NO: NSH-2100VX+ACF002-MM3		REV. -
	PROJECT: SUBMITTAL DRAWINGS	SHEET 3 OF 3	DRAWN BY: E.DICHENKO	CHECKED BY: C.LARSEN	ENGINEER: B.STEINBERG
				10/10/03 30/10/03 30/10/03	AMERICAN POWER CONVERSION 132 FAIRGROUNDS RD WEST KINGSTON, RI 02892

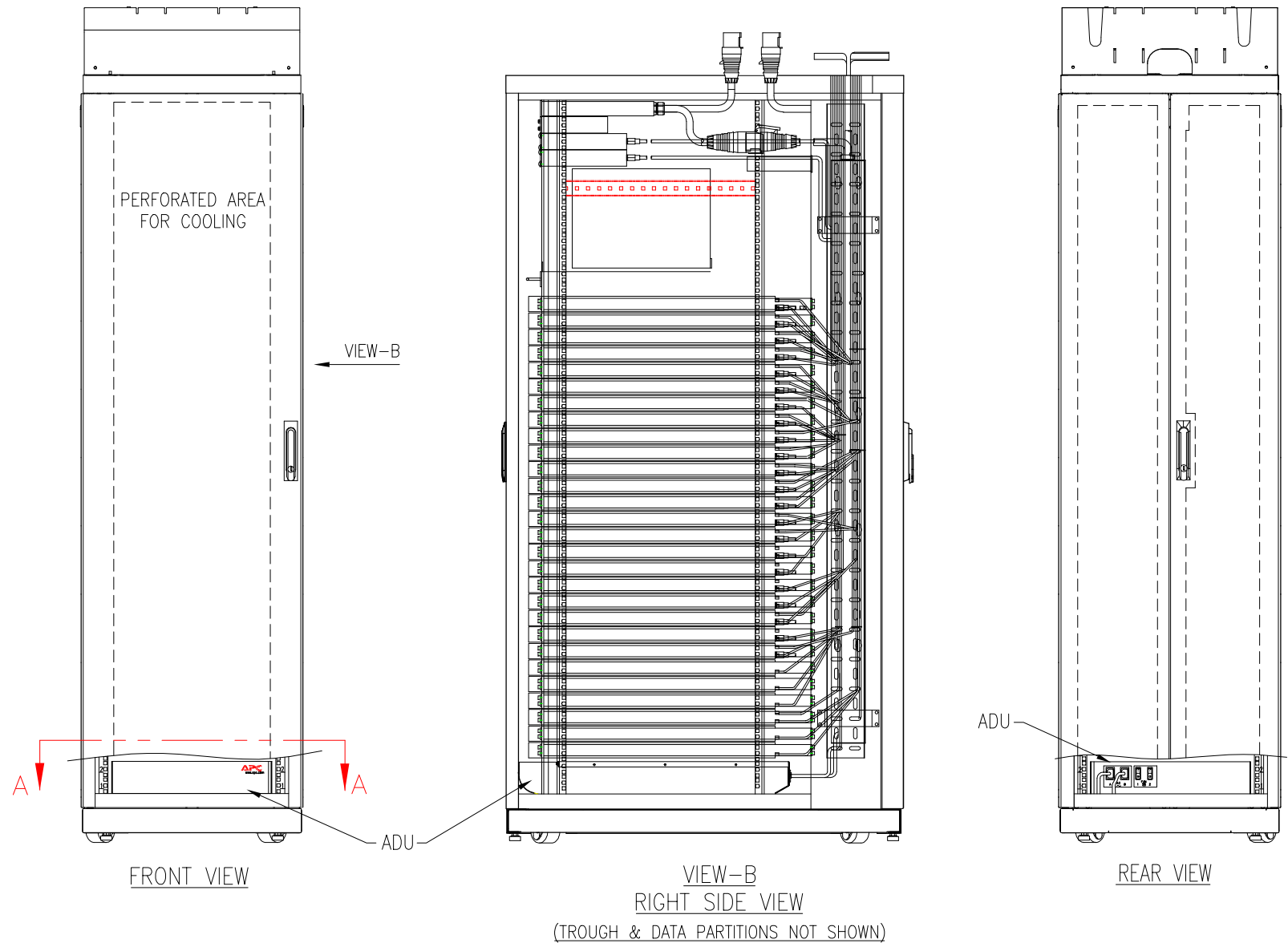

NOTE:

1. PLEASE REFER TO INSTALLATION MANUAL
2. INSTALLATION IS TYPICAL FOR ALL 600mm WIDE UNITS
3. SOME STRUCTURAL DETAILS HAVE BEEN OMITTED FOR CLARITY
4. INSTALLATION MUST COMPLY WITH NATIONAL AND LOCAL ELECTRICAL REGULATIONS.

THIS DRAWING AND SPECIFICATIONS HEREIN ARE THE PROPERTY OF AMERICAN POWER CONVERSION AND SHALL NOT BE COPIED, REPRODUCED OR USED IN WHOLE OR IN PART, AS THE BASIS FOR THE MANUFACTURE OR SALE OF ITEMS WITHOUT WRITTEN PERMISSION FROM APC. THIS DRAWING IS BASED UPON LATEST AVAILABLE INFORMATION AND IS SUBJECT TO CHANGE WITHOUT NOTICE.	TITLE: NETSHELTER VX 42U ENCLOSURE 600mm W X 1070mm D, EXPANSION UNIT WITH AIR DISTRIBUTION UNIT INSTALLED	DWG NO: NSH-2101VX+ACF002-MM1	REV. -	 AMERICAN POWER CONVERSION 132 FAIRGROUNDS RD WEST KINGSTON, RI 02892
	PROJECT: SUBMITTAL DRAWINGS SHEET 1 OF 3	DRAWN BY: JAYAPRAKASH CHECKED BY: C.LARSEN ENGINEER: B.STEINBERG	10/10/03 30/10/03 30/10/03	

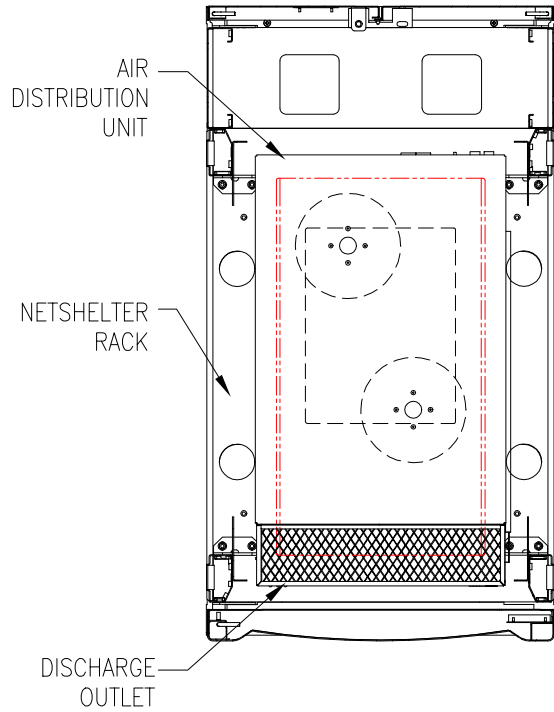

SECTION A-A (ENLARGED)
VIEW FROM INSIDE CABINET, LOOKING DOWN
(FILTER NOT SHOWN FOR CLARITY)

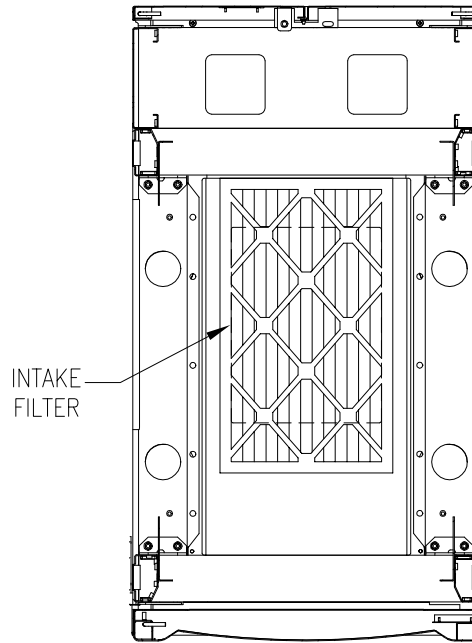

SECTION A-A (ENLARGED)
VIEW FROM INSIDE CABINET, LOOKING DOWN
(ADU NOT SHOWN)

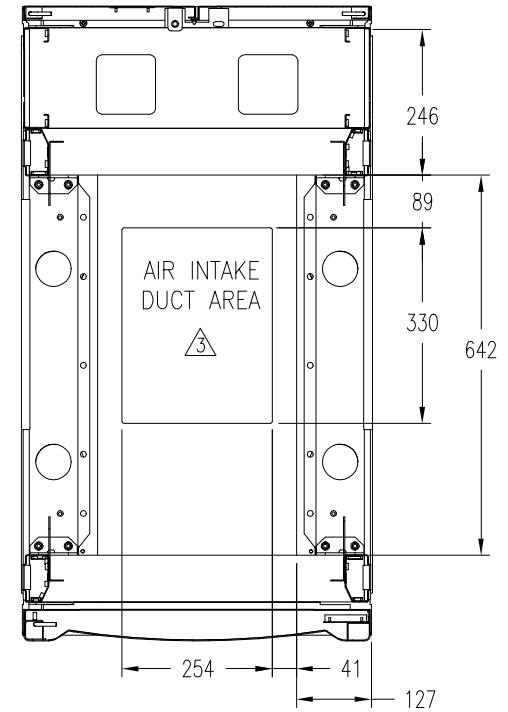

SECTION A-A (ENLARGED)
VIEW FROM INSIDE CABINET, LOOKING DOWN
(ADU AND FILTER NOT SHOWN)

NOTE:

1. PLEASE REFER TO INSTALLATION MANUAL
2. ALL DIMENSIONS ARE IN MILLIMETERS.
- △ 3. AIR INTAKE DUCT IS SHOWN AND USED FOR RAISED FLOOR APPLICATIONS ONLY
4. SOME STRUCTURAL DETAILS IN THESE SECTION VIEWS HAVE BEEN OMITTED FOR CLARITY
5. INSTALLATION MUST COMPLY WITH NATIONAL AND LOCAL ELECTRICAL REGULATIONS.

THIS DRAWING AND SPECIFICATIONS HEREIN ARE THE PROPERTY OF AMERICAN POWER CONVERSION AND SHALL NOT BE COPIED, REPRODUCED OR USED IN WHOLE OR IN PART, AS THE BASIS FOR THE MANUFACTURE OR SALE OF ITEMS WITHOUT WRITTEN PERMISSION FROM APC. THIS DRAWING IS BASED UPON LATEST AVAILABLE INFORMATION AND IS SUBJECT TO CHANGE WITHOUT NOTICE.	TITLE: NETSHELTER VX 42U ENCLOSURE 600mm W X 1070mm D, EXPANSION UNIT WITH AIR DISTRIBUTION UNIT INSTALLED	DWG NO: NSH-2101VX+ACF002-MM2	REV. -	 AMERICAN POWER CONVERSION 132 FAIRGROUNDS RD WEST KINGSTON, RI 02892
	PROJECT: SUBMITTAL DRAWINGS SHEET 2 OF 3	DRAWN BY: JAYAPRAKASH	10/10/03	
		CHECKED BY: C.LARSEN	30/10/03	
		ENGINEER: B.STEINBERG	30/10/03	

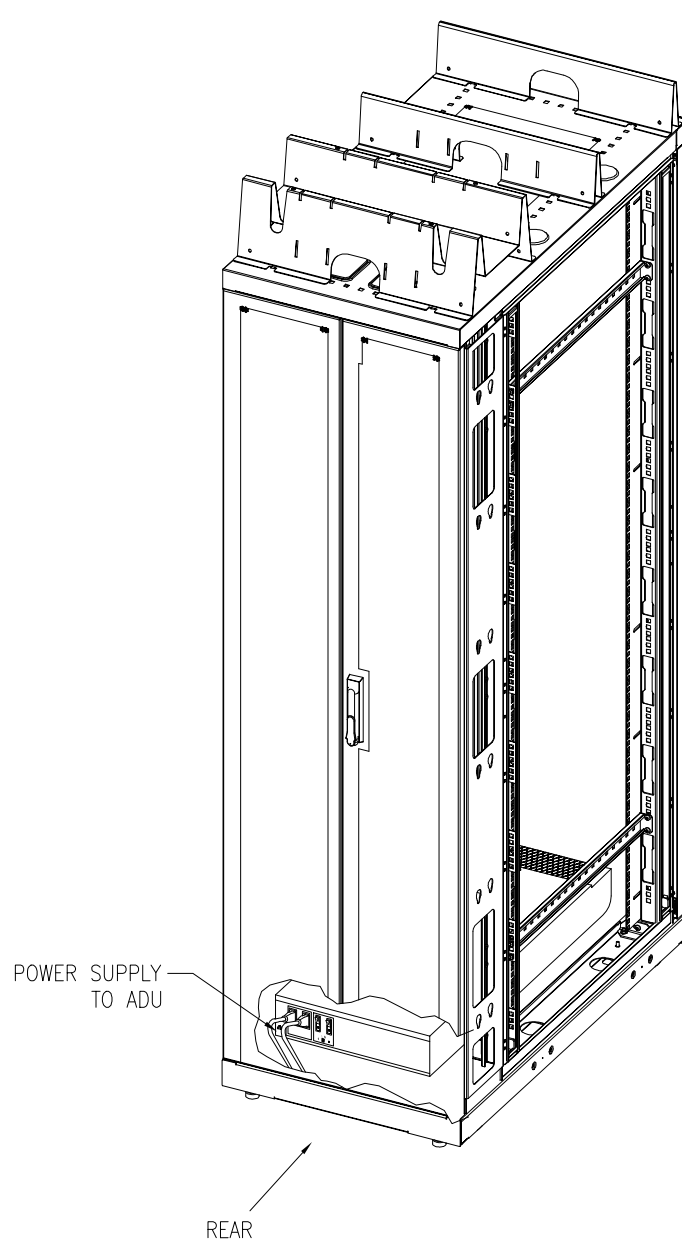
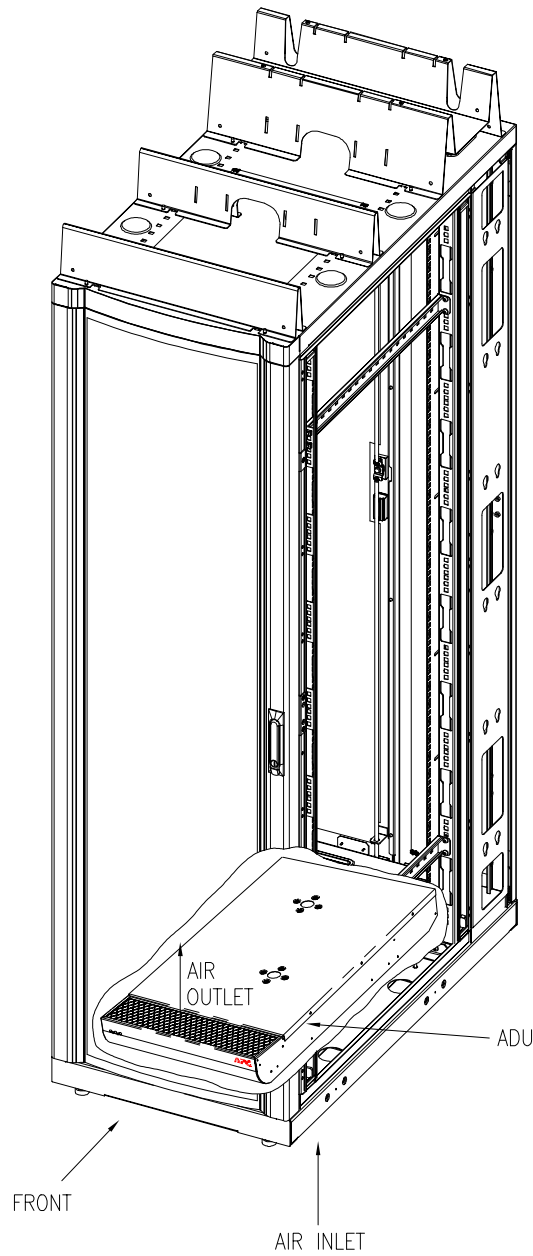

ISOMETRIC VIEW

NOTE:

1. SOME STRUCTURAL DETAILS HAVE BEEN OMITTED FOR CLARITY

THIS DRAWING AND SPECIFICATIONS HEREIN ARE THE PROPERTY OF AMERICAN POWER CONVERSION AND SHALL NOT BE COPIED, REPRODUCED OR USED IN WHOLE OR IN PART, AS THE BASIS FOR THE MANUFACTURE OR SALE OF ITEMS WITHOUT WRITTEN PERMISSION FROM APC. THIS DRAWING IS BASED UPON LATEST AVAILABLE INFORMATION AND IS SUBJECT TO CHANGE WITHOUT NOTICE.

TITLE: NETSHELTER VX 42U ENCLOSURE
600mm W X 1070mm D, EXPANSION UNIT
WITH AIR DISTRIBUTION UNIT INSTALLED

PROJECT: SUBMITTAL DRAWINGS SHEET 3 OF 3

DWG NO: NSH-2101VX+ACF002-MM3

DRAWN BY: JAYAPRAKASH	10/10/03
CHECKED BY: C.LARSEN	30/10/03
ENGINEER: B.STEINBERG	30/10/03

REV. -

PROJECTION

APC[®]

AMERICAN POWER CONVERSION
132 FAIRGROUNDS RD
WEST KINGSTON, RI 02892