

SSD1A335BDRC2

Soild state relay-DIN rail, 1phase, 48-600Vac
output, 4-32Vdc control, 35A



Main

Range of product	Harmony Relay
Product or component type	Solid state relay
Device short name	SSD1
Number of channels	1
Number of phases	1 phase
Product configuration type	Contactur configuration with pluggable screw input
Mounting support	35 mm symmetrical DIN rail EN/IEC 60715
Rated current	35 A
Contact type	1 NO

Complementary

Operating frequency	47...440 Hz
Rated duty	Uninterrupted
Output voltage	48...600 V AC
Control circuit voltage	4...32 V DC
Tightening torque	0.5 N.m control input 5 lb.in control input 2...2.2 N.m load output 18...20 lb.in load output
Connections - terminals	Input screw terminals Output telescopic screw
Dielectric strength	4 KV AC input/output circuit 4 kV AC input or output to case
Rated impulse withstand voltage	6 KV input/output circuit 6 kV input or output to case
Insulation resistance	1000 MOhm 500 V DC
Local signalling	Control voltage LED green)
Pick-up voltage	4 V DC turn-on
Drop-out voltage	1 V DC turn-off
Input current range	10...15 mA
Solid state output type	SCR output
Solid state switching type	Random voltage switching
Load current	0.15...35 A
Transient overvoltage	1200 V
Inrush current	1350 A
Maximum voltage drop	<1.15 V on-state
Motor controller rating	1.5 KW 2 hp 120 V AC 3.73 KW 5 hp 240 V AC 7.46 kW 10 hp 480 V AC

The information provided in this documentation contains general descriptions and/or technical characteristics of the performance of the products contained herein. This documentation is not intended as a substitute for and is not to be used for determining suitability or reliability of these products for specific user applications. It is the duty of any such user or integrator to perform the appropriate and complete risk analysis, evaluation and testing of the products with respect to the relevant specific application or use thereof. Neither Schneider Electric Industries SAS nor any of its affiliates or subsidiaries shall be responsible or liable for misuse of the information contained herein.

Electromagnetic compatibility	Electrostatic discharge 6 kV criteria A contact discharge IEC 61000-4-2 Electrostatic discharge 8 kV criteria A air discharge IEC 61000-4-2 Conducted RF disturbances 10 V, 0.15...80 MHz criteria A level 3 IEC 61000-4-6 Electrical fast transient/burst immunity test 2 kV, 5/100 kHz criteria B output ports IEC 61000-4-4 Electrical fast transient/burst immunity test 1 kV, 5/100 kHz criteria B input ports IEC 61000-4-4 Radiated radio-frequency electromagnetic field immunity test 10 V/m, 80 MHz...1 GHz criteria A IEC 61000-4-3 Radiated radio-frequency electromagnetic field immunity test 3 V/m, 1.4...2 GHz criteria A IEC 61000-4-3 Radiated radio-frequency electromagnetic field immunity test 1 V/m, 2...2.7 GHz criteria A IEC 61000-4-3 Surge immunity test 1 kV criteria A output ports line to line IEC 61000-4-5 Surge immunity test 2 kV criteria B output ports line to earth IEC 61000-4-5 Radiated emission environment B for DC input supply IEC 60947-4-3 Conducted emission environment B for DC input supply IEC 60947-4-3 Immunity to microbreaks and voltage drops 30 %, 500 ms criteria A IEC 61000-4-11 Immunity to microbreaks and voltage drops 100 %, 20 ms criteria B IEC 61000-4-11
Device form designation	Form 5
Maximum I ² t for fusing	8320 A ² .S 10 ms 7593 A ² .s 8.33 ms
Maximum leakage current	1 mA off-state
DV/dt	500 V/μs off-state at maximum rated voltage
Response time	0.1 ms turn-on) 0.5 cycle turn-off)
Power factor	With maximum load
Short circuit protection coordination	Type 1 Type 2
Overvoltage category	III
Maximum Width	0.89 in (22.5 mm)
Maximum Height	3.62 in (91.9 mm)
Maximum Depth	5.27 in (133.8 mm)
Net Weight	0.66 lb(US) (0.301 kg)
Device presentation	Complete product

Environment

Flammability rating	V-0 UL 94
Vibration resistance	0.75 mm 10...150 Hz) EN/IEC 60068-2-6
Shock resistance	Peak acceleration EN/IEC 60068-2-27 Peak acceleration EN/IEC 60068-2-27
Pollution degree	2
Standards	IEC 61373:class B category 1 IEC 60947-4-3 IEC 62314 IEC 60950-1 CSA C22.2 No 14-13 UL 508
IP degree of protection	IP20
Ambient air temperature for operation	-40...176 °F (-40...80 °C)
Ambient air temperature for storage	-40...212 °F (-40...100 °C)

Ordering and shipping details

Nbr. of units in pkg.	1
Package weight(Lbs)	11.43 oz (324 g)

Packing Units

Unit Type of Package 1	PCE
Package 1 Height	0.89 in (2.25 cm)
Package 1 width	3.62 in (9.19 cm)
Package 1 Length	5.27 in (13.38 cm)

Offer Sustainability

EU RoHS Directive	Pro-active compliance (Product out of EU RoHS legal scope) EU RoHS Declaration
Mercury free	Yes
RoHS exemption information	Yes
China RoHS Regulation	China RoHS Declaration
Environmental Disclosure	Product Environmental Profile
Circularity Profile	End Of Life Information
WEEE	The product must be disposed on European Union markets following specific waste collection and never end up in rubbish bins.

Dimensions

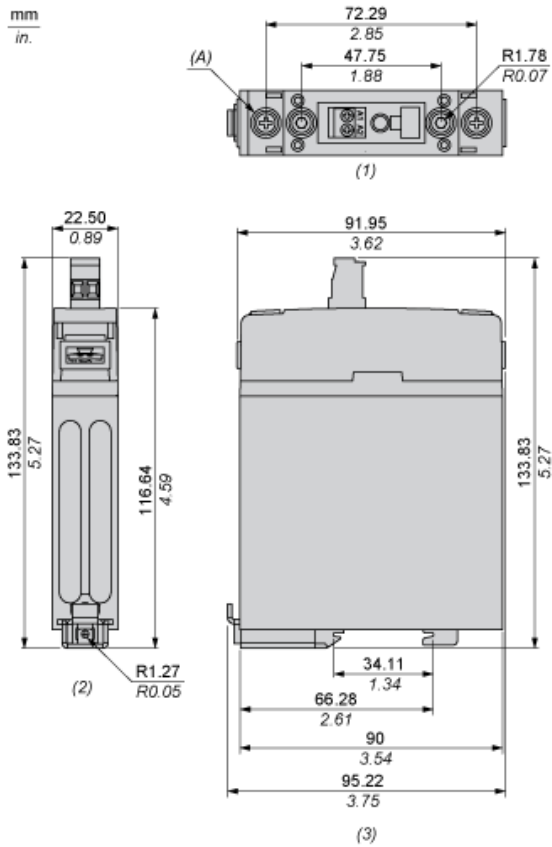

- (1) Front view
- (2) Top view
- (3) Side view
- (A) Screw 8-32 Stud Elevator Profile 1/4 48 UNS (2 Places)

Derating Curves

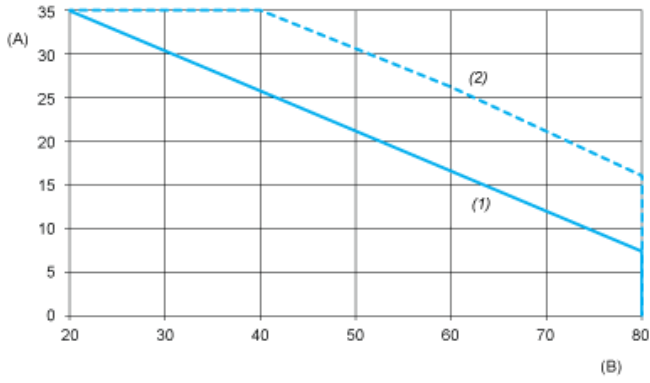

- A : Load Current (Amperes)
- B : Ambient Temperature (°C)
- 1 : Multiple units, no minimum spacing between components
- 2 : Installed single unit, distance to adjacent components more than 22.5 mm