

ConneXium

TCSESM, TCSESM-E Managed Switch Redundancy Configuration User Manual

The information provided in this documentation contains general descriptions and/or technical characteristics of the performance of the products contained herein. This documentation is not intended as a substitute for and is not to be used for determining suitability or reliability of these products for specific user applications. It is the duty of any such user or integrator to perform the appropriate and complete risk analysis, evaluation and testing of the products with respect to the relevant specific application or use thereof. Neither Schneider Electric nor any of its affiliates or subsidiaries shall be responsible or liable for misuse of the information contained herein. If you have any suggestions for improvements or amendments or have found errors in this publication, please notify us.

You agree not to reproduce, other than for your own personal, noncommercial use, all or part of this document on any medium whatsoever without permission of Schneider Electric, given in writing. You also agree not to establish any hypertext links to this document or its content. Schneider Electric does not grant any right or license for the personal and noncommercial use of the document or its content, except for a non-exclusive license to consult it on an "as is" basis, at your own risk. All other rights are reserved.

All pertinent state, regional, and local safety regulations must be observed when installing and using this product. For reasons of safety and to help ensure compliance with documented system data, only the manufacturer must perform repairs to components.

When devices are used for applications with technical safety requirements, the relevant instructions must be followed.

Failure to use Schneider Electric software or approved software with our hardware products may result in injury, harm, or improper operating results.

Failure to observe this information can result in injury or equipment damage.

© 2018 Schneider Electric. All Rights Reserved.

Contents

	Safety Information	5
	About this Manual	7
	Key	10
1	Introduction	13
1.1	Overview of Redundancy Topologies	14
1.2	Overview of Redundancy Protocols	16
2	Ring Redundancy	17
2.1	Example of a HIPER-Ring	19
2.1.1	Setting up and configuring the HIPER-Ring	21
2.2	Example of a MRP-Ring	25
2.3	Example for Fast HIPER-Ring (TCSESM-E)	32
2.4	Example for HIPER-Ring with Straight Cables	37
3	Multiple Rings	39
3.1	Sub-Ring	40
3.1.1	Sub-Ring description	40
3.1.2	Sub-Ring example	44
3.1.3	Sub-Ring example configuration	47
4	Ring/Network Coupling	53
4.1	Variants of the ring/network coupling	54
4.2	Preparing a Ring/Network Coupling	56
4.2.1	STAND-BY switch	56
4.2.2	One-Switch coupling	59
4.2.3	Two-Switch coupling	65
4.2.4	Two-Switch Coupling with Control Line	73
5	Spanning Tree	81
5.1	The Spanning Tree Protocol	83
5.1.1	The tasks of the STP	83

5.1.2	Bridge parameters	84
5.1.3	Bridge Identifier	84
5.1.4	Root Path Cost	85
5.1.5	Port Identifier	87
5.2	Rules for Creating the Tree Structure	88
5.2.1	Bridge information	88
5.2.2	Setting up the tree structure	88
5.3	Example of Root Path Determination	91
5.4	Example of Root Path Manipulation	93
5.5	Example of Tree Structure Manipulation	95
5.6	The Rapid Spanning Tree Protocol	96
5.6.1	Port roles	96
5.6.2	Port states	98
5.6.3	Spanning Tree Priority Vector	99
5.6.4	Fast reconfiguration	100
5.6.5	Configuring the Rapid Spanning Tree	101
5.7	Combining RSTP and MRP	110
5.7.1	Application example for the combination of RSTP and MRP	112
5.8	Dual RSTP (TCSESM-E)	115
5.8.1	Introduction	115
5.8.2	Coupling the Dual RSTP instances	116
5.8.3	Topologies and configuration	119
5.8.4	Application example for Dual RSTP	125
A	Index	137

Safety Information

■ Important Information

Notice: Read these instructions carefully, and look at the equipment to become familiar with the device before trying to install, operate, or maintain it. The following special messages may appear throughout this documentation or on the equipment to warn of potential hazards or to call attention to information that clarifies or simplifies a procedure.



The addition of this symbol to a Danger or Warning safety label indicates that an electrical hazard exists, which will result in personal injury if the instructions are not followed.



This is the safety alert symbol. It is used to alert you to potential personal injury hazards. Obey all safety messages that follow this symbol to avoid possible injury or death.



DANGER

DANGER indicates an imminently hazardous situation which, if not avoided, **will result in** death or serious injury.



WARNING

WARNING indicates a potentially hazardous situation which, if not avoided, **can result in** death or serious injury.



CAUTION

CAUTION indicates a potentially hazardous situation which, if not avoided, **can result in** minor or moderate injury.

PLEASE NOTE: Electrical equipment should be installed, operated, serviced, and maintained only by qualified personnel. No responsibility is assumed by Schneider Electric for any consequences arising out of the use of this material.

© 2018 Schneider Electric. All Rights Reserved.

About this Manual

Validity Note

The data and illustrations found in this book are not binding. We reserve the right to modify our products in line with our policy of continuous product development. The information in this document is subject to change without notice and should not be construed as a commitment by Schneider Electric.

Product Related Information

Schneider Electric assumes no responsibility for any errors that may appear in this document. If you have any suggestions for improvements or amendments or have found errors in this publication, please notify us.

No part of this document may be reproduced in any form or by any means, electronic or mechanical, including photocopying, without express written permission of Schneider Electric.

All pertinent state, regional, and local safety regulations must be observed when installing and using this product. For reasons of safety and to ensure compliance with documented system data, only the manufacturer should perform repairs to components.

When devices are used for applications with technical safety requirements, please follow the relevant instructions.

Failure to use Schneider Electric software or approved software with our hardware products may result in improper operating results.

Failure to observe this product related warning can result in injury or equipment damage.

User Comments

We welcome your comments about this document. You can reach us by e-mail at techpub@schneider-electric.com

Related Documents

Title	Reference Number
ConneXium TCSESM, TCSESM-E Managed Switch Redundancy Configuration User Manual	31007126
ConneXium TCSESM, TCSESM-E Managed Switch Basic Configuration User Manual	31007122
ConneXium TCSESM, TCSESM-E Managed Switch Command Line Interface Reference Manual	31007130
ConneXium TCSESM, TCSESM-E Managed Switch Web-based Interface Reference Manual	EIO0000000482
ConneXium TCSESM Managed Switch Installation Manual	31007118
ConneXium TCSESM-E Extended Managed Switch Installation Manual	EIO0000000529

Note: The Glossary is located in the Reference Manual “Command Line Interface”.

The “Redundancy Configuration” user manual contains the information you need to select a suitable redundancy procedure and configure that procedure.

The “Basic Configuration” user manual contains the information you need to start operating the device. It takes you step by step from the first startup operation through to the basic settings for operation in your environment.

The “Installation” user manual contains a device description, safety instructions, a description of the display, and the other information that you need to install the device.

The “Web-based Interface” reference manual contains detailed information on using the Web interface to operate the individual functions of the device.

The “Command Line Interface” Reference Manual contains detailed information on using the Command Line Interface to operate the individual functions of the device.

Key





The designations used in this manual have the following meanings:

▶	List
□	Work step
■	Subheading
Link	Indicates a cross-reference with a stored link
Note:	A note emphasizes an important fact or draws your attention to a dependency.
<code>Courier</code>	ASCII representation in user interface

 Execution in the Web-based Interface user interface

 Execution in the Command Line Interface user interface

Symbols used:

	WLAN access point
	Router with firewall
	Switch with firewall
	Router
	Switch

Key



Bridge



Hub



A random computer



Configuration Computer



Server



PLC -
Programmable logic
controller



I/O -
Robot

1 Introduction

The device contains a range of redundancy functions:

- ▶ HIPER-Ring
- ▶ MRP-Ring
- ▶ Fast HIPER-Ring (TCSESM-E)
- ▶ Sub-Ring (TCSESM-E)
- ▶ Ring/Network coupling
- ▶ Rapid Spanning Tree Algorithm (RSTP)
- ▶ Dual Rapid Spanning Tree algorithm (Dual RSTP, DRSTP)

1.1 Overview of Redundancy Topologies

To introduce redundancy onto layer 2 of a network, first clarify which network topology you require. Depending on the network topology selected, you then choose from the redundancy protocols that can be used with this network topology.

The following topologies are possible:

Network topology	Possible redundancy procedures	Comments
Tree structure without loops (cycle-free)	Only possible in connection with physical loops	-
Topology with 1 loop	RSTP, Ring redundancy	Ring Redundancy procedures (HIPER-Ring, Fast HIPER-Ring or MRP) provide shorter switching times than RSTP.
Topology with 2 loops	RSTP, Ring Redundancy, Sub-Ring (TCSESM-E)	Ring Redundancy: a Basis-Ring with a Sub-Ring or an MRP-Ring with an RSTP-Ring.
Topology with 3 non-nested loops	RSTP, Ring Redundancy, Sub-Ring (TCSESM-E), Dual RSTP	Dual RSTP provides specific support for the redundant coupling of an RSTP or redundant ring to another RSTP-Ring.
Topology with nested loops	RSTP, Sub-Ring (TCSESM-E), Ring coupling, Dual RSTP	Ring coupling and Dual RSTP only couple non-nested rings, though these can couple local Sub-Rings.

Table 1: Overview of Redundancy Topologies

The Ring Redundancy Protocol MRP has particular properties to offer:

- ▶ You have the option of nesting MRP-Rings. A coupled ring is known as a Sub-Ring ([see on page 40 “Sub-Ring”](#)).
- ▶ You have the option of coupling to MRP-Rings other ring structures that work with RSTP ([see on page 110 “Combining RSTP and MRP”](#)).

The Dual RSTP protocol (for the TCSESM-E device) has particular properties:

- ▶ You have the option of coupling 2 RSTP-Rings redundantly, whereby the two rings work with independent RSTP instances. You can thus also minimize the reconfiguration time in extended Layer 2 networks, when network components become inoperable ([see on page 115 “Dual RSTP \(TCSESM-E\)”](#)).
- ▶ You have the option of operating the primary ring with a ring redundancy protocol rather than with RSTP, and of coupling other ring structures that work with RSTP to the Dual RSTP primary ring ([see on page 119 “Configuration of the primary ring”](#)).

1.2 Overview of Redundancy Protocols

Redundancy procedure	Network topology	Switch-over time
RSTP	Random structure	typically < 1 s (STP < 30 s), up to < 30 s - depends heavily on the number of devices Note: Up to 79 devices possible, depending on topology and configuration. If the default values (factory settings) are used, up to 39 devices are possible, depending on the topology (see on page 81 "Spanning Tree").
Dual RSTP	Coupling of 2 RSTP rings via 2 partner bridges	< 50 ms when using up to 16 TCSESM-E devices in the secondary ring, with optimal configuration of RSTP bridge priorities.
HIPER-Ring	Ring	typically 80 ms, up to < 500 ms or < 300 ms (selectable) - the number of switches has a minimal effect on the switch-over time
MRP-Ring	Ring	typically 80 ms, up to < 500 ms or < 200 ms (selectable) - the number of switches has a minimal effect on the switch over time Note: In combination with RSTP in MRP compatibility mode, up to 39 devices are possible, depending on the configuration. If the default values (factory settings) for RSTP are used, up to 19 devices are possible (see on page 81 "Spanning Tree").
Fast HIPER-Ring (TCSESM-E)	Ring	< 25 ms with 50 devices in ring.
Sub-Ring (TCSESM-E)	Ring segment coupled to a base ring	typically 80 ms, up to < 500 ms or < 200 ms (selectable) - practically independently of the number of devices.

Table 2: Comparison of the redundancy procedures

Note: When you are using a redundancy function, you deactivate the flow control on the participating ports. Default setting: flow control deactivated globally and activated on all ports.

If the flow control and the redundancy function are active at the same time, the redundancy may not work as intended.

2 Ring Redundancy

The concept of ring redundancy allows the construction of high-availability, ring-shaped network structures.

With the help of the RM (**R**ing **M**anager) function, the two ends of a backbone in a line structure can be closed to a redundant ring. The ring manager keeps the redundant line open as long as the line structure is intact. If a segment becomes inoperable, the ring manager immediately closes the redundant line, and line structure is intact again.

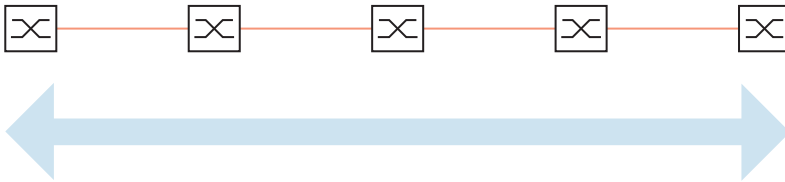

Figure 1: Line structure

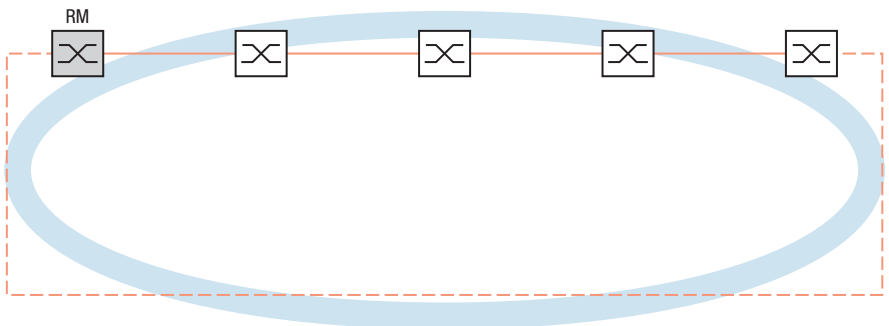

Figure 2: Redundant ring structure

RM = Ring Manager

— main line

- - - redundant line

If a section is down, the ring structure of a

- ▶ HIPER-(**HIGH PERFORMANCE REDUNDANCY**) Ring with up to 50 devices typically transforms back to a line structure within 80 ms (possible settings: standard/accelerated).
- ▶ MRP (**Media Redundancy Protocol**) Ring (IEC 62439) of up to 50 devices typically transforms back to a line structure within 80 ms (adjustable to max. 200 ms/500 ms).
- ▶ Fast HIPER-Ring of up to 5 devices typically transforms back to a line structure within 5 ms (maximum 10 ms). With a larger number of devices, the reconfiguration time increases.

Devices with HIPER-Ring function capability:

- ▶ Within a HIPER-Ring, you can use any combination of the following devices:
 - TCSESM
 - TCSESM-E
- ▶ Within an MRP-Ring, you can use devices that support the MRP protocol based on IEC62439:
 - TCSESM
 - TCSESM-E
- ▶ Within a Fast HIPER-Ring, you can use the following device:
 - TCSESM-E

Note: Enabled Ring Redundancy methods on a device are mutually exclusive at any one time. When changing to another Ring Redundancy method, deactivate the function for the time being.

Note: The following usage of the term “ring manager” instead of “redundancy manager” makes the function easier to understand.

2.1 Example of a HIPER-Ring

A network contains a backbone in a line structure with 3 devices. To increase the redundancy reliability of the backbone, you have decided to convert the line structure to a HIPER-Ring. You use ports 1.1 and 1.2 of the devices to connect the lines¹.

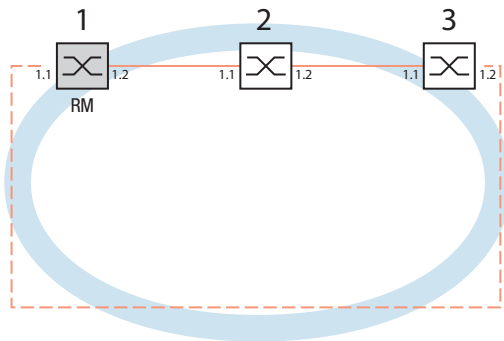

Figure 3: Example of HIPER-Ring
RM = Ring Manager
— main line
- - - redundant line

The following example configuration describes the configuration of the ring manager device (1). The two other devices (2 to 3) are configured in the same way, but without activating the ring manager function. Select the “Standard” value for the ring recovery, or leave the field empty.

1. On modular devices the 1st number of the port designation specifies the module. The 2nd number specifies the port on the module. The specification pattern 1.x is also used on non-modular devices for consistency.

Note: As an alternative to using software to configure the HIPER-Ring, with device TCSESM you can also use a DIP switch to enter a number of settings. You can also use a DIP switch to enter a setting for whether the configuration via DIP switch or the configuration via software has priority. The state on delivery is “Software Configuration”. You can find details on the DIP switches in the User Manual Installation.



WARNING

RING LOOP HAZARD

To avoid loops during the configuration phase, configure all the devices of the HIPER-Ring individually. Before you connect the redundant line, you must complete the configuration of all the devices of the HIPER-Ring.

Failure to follow these instructions can result in death, serious injury, or equipment damage.

2.1.1 Setting up and configuring the HIPER-Ring

- Set up the network to meet your demands.
- Configure all ports so that the transmission speed and the duplex settings of the lines correspond to the following table:

Bit rate	100 Mbit/s	1000 Mbit/s
Autonegotiation (automatic configuration)	off	on
Port	on	on
Duplex	Full	–

Table 3: Port settings for ring ports

Note: When activating the HIPER-Ring function via software or DIP switches, the device sets the corresponding settings for the pre-defined ring ports in the configuration table (transmission rate and mode). If you switch off the HIPER-Ring function, the ports, which are changed back into normal ports, keep the ring port settings. Independently of the DIP switch setting, you can still change the port settings via the software.

- Select the `Redundancy:Ring Redundancy` dialog.
- Under “Version”, select `HIPER-Ring`.
- Define the desired ring ports 1 and 2 by making the corresponding entries in the module and port fields. If it is not possible to enter a module, then there is only one module in the device that is taken over as a default.

Display in “Operation” field:

- `active`: This port is switched on and has a link.
- `inactive`: This port is switched off or it has no link.

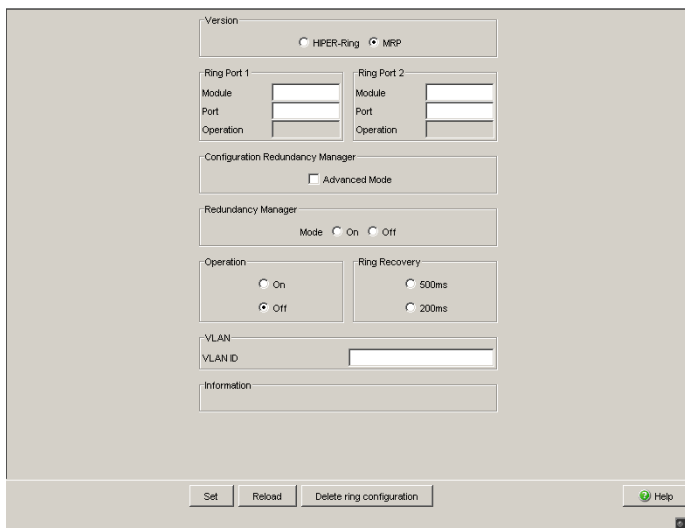

Figure 4: Ring Redundancy Dialog TCSESM

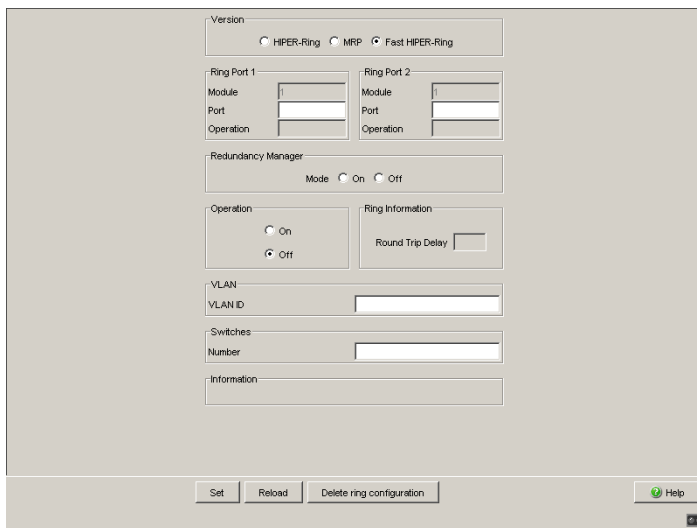

Figure 5: Ring Redundancy dialog (TCSESM-E)

- Activate the ring manager for this device. Do not activate the ring manager for any other device in the HIPER-Ring.
- In the “Ring Recovery” frame, select the value “Standard” (default).
Note: Settings in the “Ring Recovery” frame only take effect for devices configured as ring managers.
- Click “Set” to temporarily save the entry in the configuration.

```

enable                               Switch to the Privileged EXEC mode.
configure                             Switch to the Configuration mode.
hiper-ring mode ring-manager          Select the HIPER-Ring ring redundancy and
                                       define the device as ring manager.

Switch's HIPER Ring mode set to ring-manager
hiper-ring port primary 1/1           Define port 1 in module 1 as ring port 1.
HIPER Ring primary port set to 1/1
hiper-ring port secondary 1/2         Define port 1 in module 2 as ring port 1.
HIPER Ring secondary port set to 1/2
exit                                   Switch to the privileged EXEC mode.
show hiper-ring                       Display the HIPER-Ring parameters.

HIPER Ring Mode of the Switch..... ring-manager
  configuration determined by..... management
HIPER Ring Primary Port of the Switch..... 1/1, state active
HIPER Ring Secondary Port of the Switch..... 1/2, state active
HIPER Ring Redundancy Manager State..... active
HIPER Ring Redundancy State (red. exists).. no (rm is active)
HIPER Ring Setup Info (Config. failure)..... no error
HIPER Ring Recovery Delay..... 500ms

```

- Now proceed in the same way for the other two devices.

Note: In the configuration of the HIPER-Ring, you select for the ring ports

- VLAN ID 1 and
- VLAN membership Untagged in the static VLAN table.

Note: Deactivate the Spanning Tree protocol for the ports connected to the HIPER-Ring, because Spanning Tree and Ring Redundancy affect each other.

If you used the DIP switch to activate the function of HIPER-Ring, RSTP is automatically switched off.

- Now you connect the line to the ring. To do this, you connect the 2 devices to the ends of the line using their ring ports.

The displays in the “Redundancy Manager Status” frame mean:

- “Active (redundant line)”: The ring is open, which means that a data line or a network component within the ring is down.
- “Inactive”: The ring is closed, which means that the data lines and network components are working.

The displays in the “Information” frame mean

- “Redundancy existing”: One of the lines affected by the function may be interrupted, with the redundant line then taking over the function of the interrupted line.
- “Configuration failure”: The function is incorrectly configured or the cable connections at the ring ports are improperly configured (e.g., not plugged into the ring ports).

Note: For devices with DIP switches, put all DIP switches to “On”. The effect of this is that you can use the software configuration to configure the redundancy function without any restrictions. You thus avoid the possibility of the software configuration being hindered by the DIP switches.

2.2 Example of a MRP-Ring

A network contains a backbone in a line structure with 3 devices. To increase the availability of the backbone, you decide to convert the line structure to a redundant ring. In contrast to the previous example, devices from different manufacturers are used which do not all support the HIPER-Ring protocol. However, all devices support MRP as the ring redundancy protocol, so you decide to deploy MRP. You use ports 1.1 and 2.2 of the devices to connect the lines.

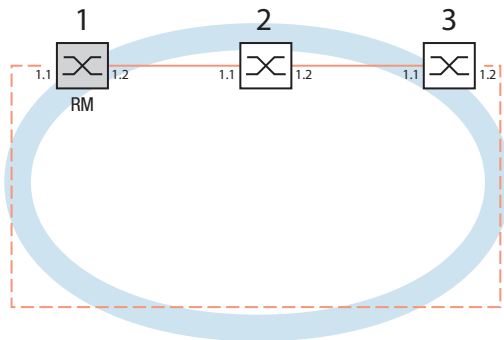

Figure 6: Example of MRP-Ring
RM = Ring Manager
— main line
- - - redundant line

The following example configuration describes the configuration of the ring manager device (1). You configure the 2 other devices (2 to 3) in the same way, but without activating the ring manager function. This example does not use a VLAN. You have entered 200 ms as the ring recovery time, and all the devices support the advanced mode of the ring manager.

Note: For devices with DIP switches, put all DIP switches to “On”. The effect of this is that you can use the software configuration to configure the redundancy function without any restrictions. You thus avoid the possibility of the software configuration being hindered by the DIP switches.



WARNING

RING LOOP HAZARD

To avoid loops during the configuration phase, configure all the devices of the MRP-Ring individually. Before you connect the redundant line, you must complete the configuration of all the devices of the MRP-Ring.

Failure to follow these instructions can result in death, serious injury, or equipment damage.

- Set up the network to meet your demands.
- Configure all ports so that the transmission speed and the duplex settings of the lines correspond to the following table:

Bit rate	100 Mbit/s	1000 Mbit/s
Autonegotiation (automatic configuration)	off	on
Port	on	on
Duplex	Full	–

Table 4: Port settings for ring ports

- Select the Redundancy:Ring Redundancy dialog.
- Under “Version”, select MRP.

- Define the desired ring ports 1 and 2 by making the corresponding entries in the module and port fields. If it is not possible to enter a module, then there is only one module in the device that is taken over as a default.

Display in “Operation” field:

- ▶ forwarding: this port is switched on and has a link.
- ▶ blocked: this port is blocked and has a link
- ▶ disabled: this port is disabled
- ▶ not-connected: this port has no link

The screenshot shows the 'Ring Redundancy Dialog' in TCSEM. The dialog is titled 'Version' and has two radio buttons: 'HIPER-Ring' (unselected) and 'MRP' (selected). Below this, there are two columns for 'Ring Port 1' and 'Ring Port 2'. Each column has three input fields: 'Module' (containing '1'), 'Port' (containing '1'), and 'Operation' (empty). Underneath these is a 'Configuration Redundancy Manager' section with a checked 'Advanced Mode' checkbox. Below that is a 'Redundancy Manager' section with a 'Mode' field containing 'On'. The 'Operation' section has 'On' and 'Off' radio buttons, with 'Off' selected. The 'Ring Recovery' section has '500ms' and '200ms' radio buttons, with '200ms' selected. At the bottom, there is a 'VLAN' section with a 'VLAN ID' input field. The 'Information' section is empty. At the very bottom, there are buttons for 'Set', 'Reload', 'Delete ring configuration', and 'Help'.

Figure 7: Ring Redundancy Dialog TCSEM

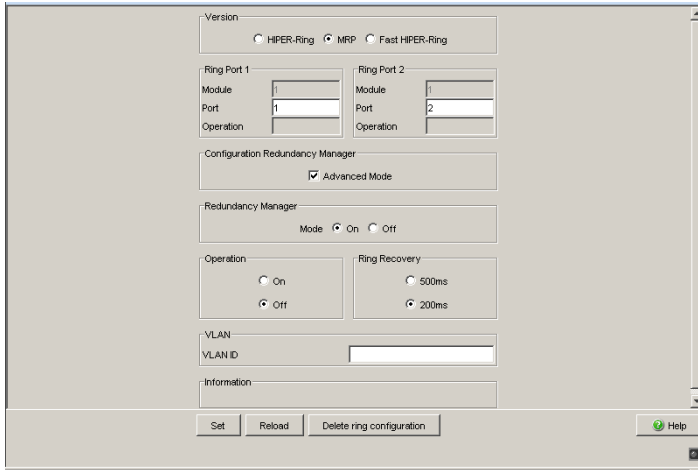

Figure 8: Ring Redundancy dialog (TCSESM-E)

- In the “Ring Recovery” frame, select 200 ms.

Note: If selecting 200 ms for the ring recovery does not provide the ring stability necessary to meet the requirements of your network, you select 500 ms.

Note: Settings in the “Ring Recovery” frame only take effect for devices configured as ring managers.

- Under “Configuration Redundancy Manager”, activate the advanced mode.
- Activate the ring manager for this device. Do not activate the ring manager for any other device in the MRP-Ring.
- Leave the VLAN ID as 0 in the VLAN field.
- Switch the operation of the MRP-Ring on.
- Click “Set” to temporarily save the entry in the configuration.

The displays in the “Information” frame mean

- “Redundancy existing”: One of the lines affected by the function may be interrupted, with the redundant line then taking over the function of the interrupted line.
- “Configuration failure”: The function is incorrectly configured or the cable connections at the ring ports are improperly configured (e.g., not plugged into the ring ports).

The “VLAN” frame enables you to assign the MRP-Ring to a VLAN:

- If VLANs are configured, you make the following selections in the “VLAN” frame:
 - VLAN ID 0, if the MRP-Ring configuration is not to be assigned to a VLAN, as in this example.
Select VLAN ID 1 and VLAN membership \cup (Untagged) in the static VLAN table for the ring ports.
 - A VLAN ID > 0, if the MRP-Ring configuration is to be assigned to this VLAN.
For all devices in this MRP-Ring, enter this VLAN ID in the MRP-Ring configuration, and then choose this VLAN ID and the VLAN membership Tagged (T) in the static VLAN table for all ring ports in this MRP-Ring.

Note: if you want to use the redundancy protocol RSTP (see on page 81 “Spanning Tree”) in an MRP-Ring, activate the MRP compatibility in the Rapid Spanning Tree:Global dialog on all devices in the MRP-Ring because RSTP (Spanning Tree) and ring redundancy affect each other. If this is not possible, perhaps because individual devices do not support the MRP compatibility, you deactivate RSTP at the ports connected to the MRP-Ring.

Note: When you are configuring an MRP-Ring using the Command Line Interface, you define an additional parameter. When configured using CLI, an MRP-Ring is addressed via its MRP domain ID. The MRP domain ID is a sequence of 16 number blocks (8-bit values). Use the default domain of 255 255 255 255 255 255 255 255 255 255 255 255 255 255 255 for the MRP domain ID.

This default domain is also used internally for a configuration via the Web-based interface.

Configure all the devices within an MRP-Ring with the same MRP domain ID.

```

enable                               Switch to the Privileged EXEC mode.
configure                             Switch to the Configuration mode.
mrp new-domain                         Create a new MRP-Ring with the default domain
  default-domain                       ID
                                       255.255.255.255.255.255.255.255.255.255.
                                       255.255.255.255.255

MRP domain created:
Domain ID:
255.255.255.255.255.255.255.255.255.255.255.255
  (Default MRP domain)
mrp current-domain                     Define port 1 in module 1 as ring port 1 (primary).
  port primary 1/1
Primary Port set to 1/1
mrp current-domain                     Define port 2 in module 1 as ring port 2
  port secondary 1/2                   (secondary).
Secondary Port set to 1/2

mrp current-domain mode                Define this device as the ring manager.
manager
Mode of Switch set to Manager
mrp current-domain recovery-          Define 200ms as the value for the "Ring
delay 200ms                           Recovery".
Recovery delay set to 200ms
mrp current-domain advanced-         Activate the "MRP Advanced Mode".
mode enable
Advanced Mode (react on link change) set to Enabled
mrp current-domain                    Activate the MRP-Ring.
  operation enable
Operation set to Enabled
exit                                   Go back one level.
show mrp                               Show the current parameters of the MRP-Ring
                                       (abbreviated display).

Domain ID:
255.255.255.255.255.255.255.255.255.255.255.255
  (Default MRP domain)

Configuration Settings:
Advanced Mode (react on link change)... Enabled
Manager Priority..... 32768
Mode of Switch (administrative setting). Manager
Mode of Switch (real operating state)... Manager
Domain Name..... <empty>
Recovery delay..... 200ms
Port Number, Primary..... 1/1, State: Not Connected
Port Number, Secondary..... 1/2, State: Not Connected
VLAN ID..... 0 (No VLAN)
Operation..... Enabled

```

- Now you connect the line to the ring. To do this, you connect the 2 devices to the ends of the line using their ring ports.

2.3 Example for Fast HIPER-Ring (TCSESM-E)

This example can be set up with the device type TCSESM-E. A network contains a backbone in a line structure with 3 devices. To increase the redundancy reliability of the backbone, you have decided to convert the line structure to a ring redundancy. In contrast to the previous example, you need a very short switch-over time in a redundancy case (about 10 ms). Only TCSESM-E devices are being used, so you decide on the Fast HIPER-Ring as the ring redundancy protocol. You use ports 1.1 and 1.2 of the devices to connect the lines.

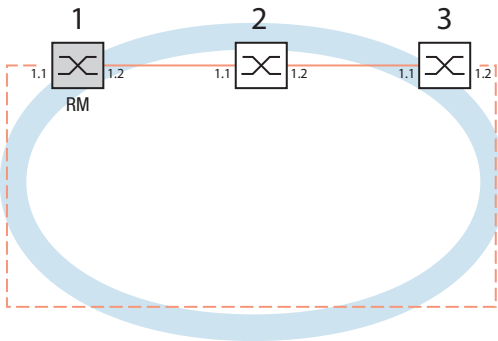

Figure 9: Example of Fast HIPER-Ring
 RM = Ring Manager
 — main line
 - - - redundant line

The following example configuration describes the configuration of the ring manager device (1). The 2 other devices (2 to 3) are configured in the same way, but without activating the ring manager function. No VLAN used in this example.

WARNING
RING LOOP HAZARD

To avoid loops during the configuration phase, configure all the devices of the Fast HIPER-Ring individually. Before you connect the redundant line, you must complete the configuration of all the devices of the Fast HIPER-Ring.

Failure to follow these instructions can result in death, serious injury, or equipment damage.

- Set up the network to meet your demands.
- Configure all ports so that the transmission speed and the duplex settings of the lines correspond to the following table:

Bit rate	100 Mbit/s
Autonegotiation (automatic configuration)	off
Port	on
Duplex	Full

Table 5: Port settings for ring ports

- Select the `Redundancy:Ring Redundancy` dialog.
- Under “Version”, select `Fast HIPER-Ring`.
- Define the desired ring ports 1 and 2 by making the corresponding entries in the module and port fields. If it is not possible to enter a module, then there is only one module in the device that is taken over as a default.

Display in “Operation” field:

- ▶ `forwarding`: this port is switched on and has a link.
- ▶ `blocked`: this port is blocked and has a link
- ▶ `disabled`: this port is disabled
- ▶ `not-connected`: this port has no link

Figure 10: Ring Redundancy dialog (TCSESM-E)

- Activate the ring manager for this device. Do not activate the ring manager for any other device in the Fast HIPER-Ring.
- Activate the function in the “Operation” frame.
- Leave the VLAN ID as 0 in the VLAN field.
- In the “Switches” frame, enter the number of Switches in the ring in “Number”. This entry is used to optimize the reconfiguration time and the stability of the ring.
- Click “Set” to temporarily save the entry in the configuration.

The display in the “Ring Information” frame means:

- Round Trip Delay: round-trip delay in μs for test packets, measured by the ring manager.
Display begins with 100 μs , in steps of 100 μs . Values of 1000 μs and greater indicate that the ring may become unstable. In this case, check that the entry for the number of Switches in the “Switches” frame is correct.

The displays in the “Information” frame mean

- “Redundancy existing”: One of the lines affected by the function may be interrupted, with the redundant line then taking over the function of the interrupted line.
- “Configuration failure”: The function is incorrectly configured or the cable connections at the ring ports are improperly configured (e.g., not plugged into the ring ports).

The “VLAN” frame enables you to assign the Fast HIPER-Ring to a VLAN:

- If VLANs are configured, you make the following selections in the “VLAN” frame:
 - VLAN ID 0, if the Fast HIPER-Ring configuration is not to be assigned to a VLAN, as in this example.
Select VLAN ID 1 and VLAN membership \cup (Untagged) in the static VLAN table for the ring ports.
 - A VLAN ID > 0, if the Fast HIPER-Ring configuration is to be assigned to this VLAN.
For all devices in this Fast HIPER-Ring, enter this VLAN ID in the Fast HIPER-Ring configuration, and then choose this VLAN ID and the VLAN membership \cap (Tagged) in the static VLAN table for all ring ports in this Fast HIPER-Ring.

Note: If you want to configure a Fast HIPER-Ring using the **Command Line Interface (CLI)**, confirm that you define an additional parameter. When configured using CLI, a Fast HIPER-Ring is addressed via its Fast HIPER-Ring ID. This ID is a number in the value range 1 to 2,147,480,647 ($2^{31} - 1$). The default setting is 1. The device also uses this value internally for a configuration via the Web-based interface. Configure all the devices within a Fast HIPER-Ring with the same Fast HIPER-Ring ID.

<pre>enable configure fast-hiper-ring new-id default-id</pre>	<p>Switch to the Privileged EXEC mode. Switch to the Configuration mode. Create a new Fast HIPER-Ring with the default ID (1). Ports 1/1 and 1/2 are defined as ring ports here. You keep these default values.</p>
<pre>Fast HIPER-Ring ID created:ID: 1 (Default Fast HIPER-Ring ID)</pre>	

<pre>fast-hiper-ring current-id mode ring-manager Mode of Switch set to Ring Manager fast-hiper-ring current-id nodes 3</pre>	<p>Define this device as the ring manager. Mode of Switch set to Ring Manager Define the number of devices in the Fast HIPER-Ring as 3.</p>
---	---

```

Number of nodes set to 3
fast-hiper-ring current-id      Activate the Fast HIPER-Ring.
operation enable
Operation set to Enabled
exit                             Switch to the Configuration mode.
show fast-hiper-ring           Show the current parameters of the Fast HIPER-
                               Ring.

Ring ID: 1
      (Default Fast HIPER-Ring ID)
Mode of Switch (administrative setting). Ring Manager
Mode of Switch (real operating state)... Ring Manager
Ring Name.....<empty>
Number of nodes in the ring..... 3
Port Number, Primary..... 1/1, State: Not Connected
Port Number, Secondary..... 1/2, State: Not Connected
VLAN ID..... 0 (No VLAN)
Operation..... Enabled

General Operating States:
FHR Setup Info (Config. Failure)..... Ring Port Link Error

Manager-related Operating States:
Ring State..... Open
Redundancy Guaranteed..... No
Round Trip Delay..... 0

```

Note: Deactivate the Spanning Tree protocol (STP) for the ports connected to the redundant ring, because the Spanning Tree and the Ring Redundancy work with different reaction times (Redundancy:Spanning Tree:Port).

- Now you connect the line to the ring. To do this, you connect the 2 devices to the ends of the line using their ring ports.

2.4 Example for HIPER-Ring with Straight Cables

You can set up this example with models TCSESM, TCSESM-E or TCSESB.

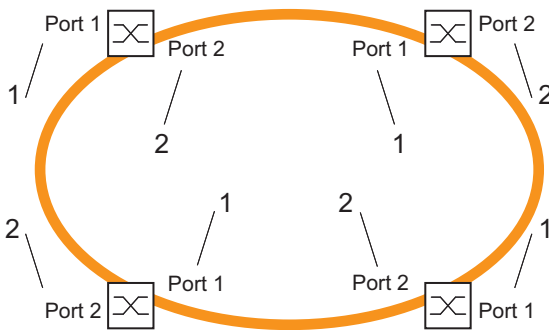

Figure 11: Example for a HIPER-Ring with straight cables
1 = Manual Cable Crossing disabled
2 = Manual Cable Crossing enabled

The following example configuration describes the configuration of a HIPER-Ring where straight cables are used between the switches, in contrast to the normal case, where crossed cables are used between switches. The choice which switch is assigned the ring manager function as well as which line is assigned the redundant line in the normal mode of operation, is independent from that and is therefore not given in the example.

**WARNING****RING LOOP HAZARD**

To avoid loops during the configuration phase, configure all the devices of the HIPER-Ring individually. Before you connect the redundant line, you must complete the configuration of all the devices of the HIPER-Ring.

Failure to follow these instructions can result in death, serious injury, or equipment damage.

- Set up the network to meet your demands.
- Configure the transmission rate, the duplex mode and the manual cable crossing for all ring ports as given in the following table:

Port	1.1	1.2
Port on	yes (checked)	yes (checked)
Autonegotiation (Automatic Configuration)	no (not checked)	no (not checked)
Manual Configuration	100 Mbit/s FDX	100 Mbit/s FDX
Manual Cable Crossing	disable	enable

Table 6: Port settings for ring ports when using straight cables

Note: You can also use the ring redundancy protocol MRP instead of HIPER-Ring; when employing TCSESM-E switches, you can also use Fast HIPER-Ring.

3 Multiple Rings

The device allows you to set up multiple rings with different redundancy protocols:

- ▶ You have the option of nesting MRP-Rings. A coupled ring is known as a Sub-Ring ([see on page 40 “Sub-Ring”](#)).
- ▶ You have the option of coupling to MRP-Rings other ring structures that work with RSTP ([see on page 110 “Combining RSTP and MRP”](#)).

3.1 Sub-Ring

3.1.1 Sub-Ring description

For the device TCSESM-E.

The Sub-Ring concept enables you to easily couple new network segments to suitable devices in existing redundancy rings (primary rings). The devices of the primary ring to which the new Sub-Ring is being coupled are referred to as Sub-Ring Managers (SRMs).

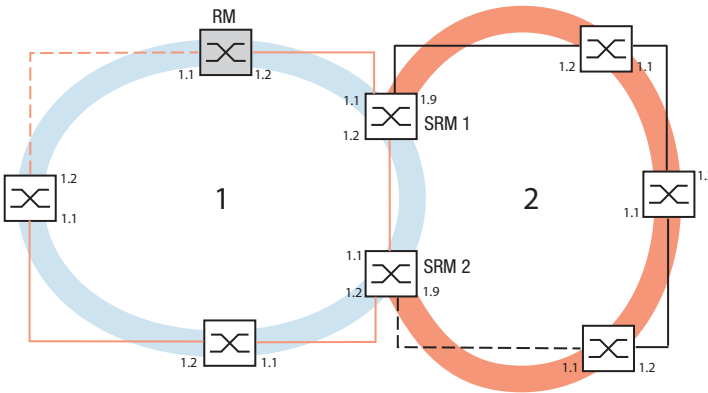

Figure 12: Example for Sub-Ring structure

- 1 blue ring = Base Ring
- 2 orange ring = Sub Ring
- SRM = Sub-Ring Manager
- RM = Ring Manager

Note: The following devices support the Sub-Ring Manager function:

- TCSESM-E

The SRM-capable devices support up to 4 SRM instances and can thus be the Sub-Ring manager for up to 4 Sub-Rings at the same time.

In a Sub-Ring, you can integrate as participants the devices that support MRP - the Sub-Ring Manager function is not required.

Each Sub Ring may consist of up to 200 participants. The SRMs themselves and the switches placed in the Base Ring between the SRMs do not count here.

Setting up Sub-Rings has the following advantages:

- ▶ Through the coupling process, you include the new network segment in the redundancy concept.
- ▶ You can easily integrate new company areas into existing networks.
- ▶ You easily map the organizational structure of a company in the network topology.
- ▶ As an MRP-Ring, the switching times of the Sub-Ring in redundancy cases are typically < 100 ms.

The following graphics show examples of possible Sub-Ring topologies:

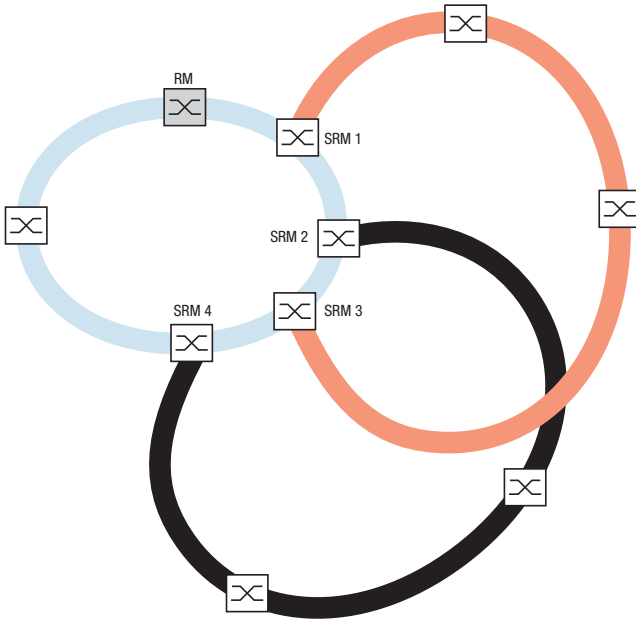

Figure 13: Example of an overlapping Sub-Ring structure

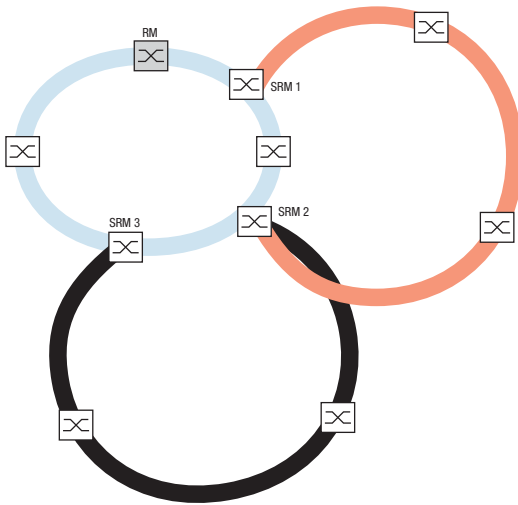

Figure 14: Special case: a Sub-Ring Manager manages 2 Sub-Rings (2 instances). Depending on the device type, you can configure additional instances.

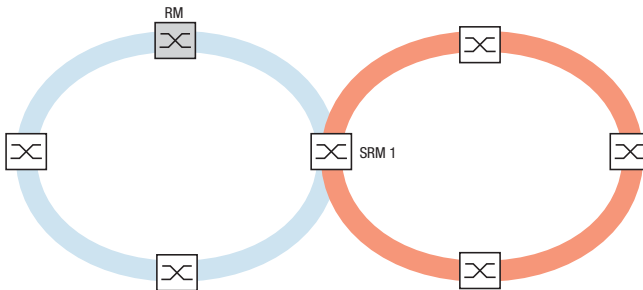

Figure 15: Special case: a Sub-Ring Manager manages both ends of a Sub-Ring at different ports (Single Sub-Ring Manager).

Note: Connect Sub-Rings only to existing primary rings. Do not cascade Sub-Rings (i.e., confirm that a new Sub-Ring is not connected to an existing Sub-Ring).

Note: Sub-Rings use MRP. You can couple Sub-Rings to existing primary rings with the HIPER-Ring protocol, the Fast HIPER-Ring protocol and MRP. If you couple a Sub-Ring to a primary ring under MRP, configure both rings in different VLANs. You configure

- ▶ either the Sub-Ring Managers' Sub-Ring ports and the devices of the Sub-Ring in a separate VLAN. Here multiple Sub-Rings can use the same VLAN.
- ▶ or the devices of the primary ring including the Sub-Ring Managers' primary ring ports in a separate VLAN. This reduces the configuration effort when coupling multiple Sub-Rings to a primary ring.

3.1.2 Sub-Ring example

You want to couple a new network segment with 3 devices to an existing redundant ring with the HIPER-Ring protocol. If you couple the network at both ends instead of only one end, this provides increased availability with the corresponding configuration.

The new network segment will be coupled as a Sub-Ring. The coupling to the primary ring is performed by existing devices of the type

- TCSESM-E

Configure these devices as Sub-Ring Managers.

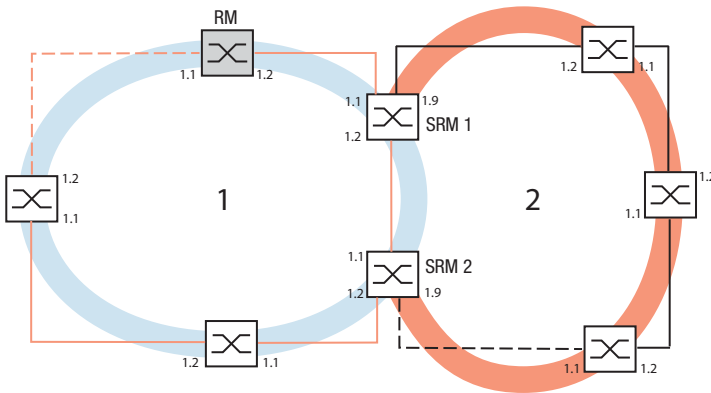

Figure 16: Example for Sub-Ring structure
 1 blue ring = Base Ring
 2 orange ring = Sub Ring
 SRM = Sub-Ring Manager
 RM = Ring Manager

Proceed as follows to configure a Sub-Ring:

- Configure the three devices of the new network segment as participants in an MRP-Ring. This means:
 - Configure the transmission rate and the duplex mode for all the ring ports in accordance with the following table:

Port Type	Bit Rate	Autonegotiation (Automatic Configuration)	Port Setting	Duplex Mode
Optical	all	off	on	full
TX	100 Mbit/s	off	on	full
TX	1000 Mbit/s	on	on	-

Table 7: Port Settings for Ring Ports

□ Other settings:

- Define different VLAN membership for the primary ring and the Sub-Ring even if the primary ring uses the MRP protocol; e.g., VLAN ID 1 for the primary ring and VLAN ID 2 for the Sub-Ring.
- For all ring ports in the Sub-Ring, select this VLAN ID and the VLAN membership Tagged (T) in the static VLAN table.
- Switch the MRP-Ring function on for all devices.
- In the Ring Redundancy dialog, under MRP-Ring, configure for all devices the two ring ports used in the Sub-Ring.
- Switch the Ring Manager function off for all devices.
- Switch RSTP off for the MRP-Ring ports used in the Sub-Ring.
- Assign the same MRP domain ID to all devices.

Note: The MRP domain ID is a sequence of 16 numbers (range 0 to 255). The default domain (in the CLI: “default-domain”) is the MRP domain ID of 255 255 255 255 255 255 255 255 255 255 255 255 255 255 255 255. A MRP domain ID consisting entirely of zeroes is invalid.

If you need to adjust the MRP domain ID, open the Command Line Interface (CLI) and proceed as follows:

enable	Switch to the Privileged EXEC mode.
configure	Switch to the Configuration mode.
mrp delete-domain current-domain	Deletes the current MRP domain. If no MRP domain exists, the device outputs an error message.
MRP current domain deleted:	
Domain ID: 255.255.255.255.255.255.255.255.255.255.255.255.255.255.255.255 (Default MRP domain)	
mrp new-domain 0.0.1.1.2.2.3.4.4.111. 222.123.0.0.66.99	Creates a new MRP domain with the specified MRP domain ID. You can subsequently access this domain with “current-domain”.
MRP domain created:	
Domain ID: 0.0.1.1.2.2.3.4.5.111.222.123.0.0.66.99	

3.1.3 Sub-Ring example configuration



WARNING

SUB-RING LOOP HAZARD

To avoid loops during the configuration phase, configure all the devices of the Sub-Ring individually. Before you connect the redundant line (close the Sub-Ring), you must complete the configuration of all the devices of the Sub-Ring.

Failure to follow these instructions can result in death, serious injury, or equipment damage.

Proceed as follows to configure the 2 Sub-Ring Managers in the example:

- Select the `Redundancy: Sub-Ring` dialog.
- Click the button "New".

Figure 17: Sub-Ring – New Entry dialog

- Enter the value “1” as the ring ID of this Sub-Ring.
- In the Module.Port field, enter the ID of the port (in the form X.X) that connects the device to the Sub-Ring (in the example, 1.9). For the connection port, you can use all the available ports that you have not already configured as ring ports of the primary ring.
- You have the option of entering a name for the Sub-Ring (in the example, “Test”).
- Select the Sub-Ring Manager mode (SRM mode). You thus specify which connection between the primary ring and the Sub-Ring becomes the redundant line.

The options for the connection are:

- ▶ Both Sub-Ring Managers have the same setting (default `manager`): - the device with the higher MAC address manages the redundant line.
- ▶ In the SRM Mode field, a device is selected to be the `redundant manager`: - this device manages the redundancy line as long as you have configured the other Sub-Ring Manager as a `manager`, otherwise the higher MAC address applies.

Configure Sub-Ring Manager 1 as the “manager” and Sub-Ring Manager 2 as the manager of the redundant line with “redundant manager”, in accordance with the overview drawing for this example.

- Leave the fields VLAN ID (default 0) and MRP Domain (default 255.255.255.255.255.255.255.255.255.255.255.255.255.255.255) as they are. The example configuration does not require any change here.
- Click "Set" to temporarily save the entry in the configuration.
- Click "Back" to return to the Sub-Ring dialog.

<pre>enable configure sub-ring new-ring 1 Sub-Ring ID created:ID: 1 sub-ring 1 port 1/9 Port set to 1/9 sub-ring 1 ring-name Test Sub-Ring Ring name set to "Test" sub-ring 1 mode manager Mode of Switch set to manager</pre>	<p>Switch to the Privileged EXEC mode.</p> <p>Switch to the Configuration mode.</p> <p>Creates a new Sub-Ring with the Sub-Ring ID 1.</p> <p>Defines port 9 in module 1 as the Sub-Ring port.</p> <p>Assigns the name "Test" to Sub-Ring 1</p> <p>Configures the mode of this Sub-Ring Manager as "manager".</p>
--	--

- Click "Reload" to update the Sub-Ring overview and check all the entries.

Max. Table Entries: 4

Sub-Ring ID	Function on/off	Configuration State	Redundancy existing	Module Port	Name	SRM Mode	SRM State	Port-Status	VLAN	Partner-MAC
1	<input type="checkbox"/>	<input checked="" type="checkbox"/>	<input checked="" type="checkbox"/>	1.9	Test	manager	manager	0	0000	000000

Buttons: Set, Reload, New, Delete entry, Help

Figure 18: Completely configured Sub-Ring Manager

- Configure the 2nd Sub-Ring Manager in the same way. If you have explicitly assigned SRM 1 the SRM mode `manager`, you configure SRM 2 as `redundant manager`. Otherwise, the assignment is performed automatically via the higher MAC address (see above)
- Switch the two Sub-Ring Managers on under “Function on/off” in the overview of the Sub-Ring dialog.
- Click “Set” to temporarily save the entry in the configuration.
- Select the dialog
Basic Settings:Load/Save.
- In the “Save” frame, select “To Device” for the location and click “Save” to permanently save the configuration in the active configuration.

```
enable
configure
sub-ring 1 operation enable
Operation set to Enabled
exit
show sub-ring
```

Switch to the Privileged EXEC mode.
Switch to the Configuration mode.
Switches on the Sub-Ring with the Sub-Ring ID 1.

Switch to the privileged EXEC mode.
Displays the state for all Sub-Rings on this device.

```
Ring ID: 1
Mode of Switch (administrative setting)... manager
Mode of Switch (real operating state).... manager
Port Number..... 1/9, State: Forwarding
Protocol..... Standard MRP
MRP Domain ID.....
255.255.255.255.255.255.255.255.255.255.255.255.255.255.255.255.255.255.255.255.255.255Ri
ng Name..... Test
Partner MAC..... 02:E3:00:1B:00:09
VLAN ID..... 0 (No VLAN)
Operation..... Enabled

General Operating States:
SRM Setup Info (Config. Failure)..... No Error

Manager-related Operating States:
Ring State..... Open
Redundancy Guaranteed..... No
copy system:running-config    Save the current configuration to the non-volatile
  nvram:startup-config        memory.
```

- When you have configured both SRMs and, if applicable, the devices included in the Sub-Ring, close the Sub-Ring's redundant line.

4 Ring/Network Coupling

Ring/Network Coupling allows the redundant coupling of redundant rings and network segments. Ring/Network Coupling connects 2 rings/network segments via 2 separate paths.

The ring/network coupling supports the coupling of a ring (HIPER-Ring, Fast HIPER-Ring or MRP) to a second ring (also HIPER-Ring, Fast HIPER-Ring or MRP) or to a network segment of any structure, when all the devices in the coupled network are Schneider Electric devices.

The ring/network coupling supports the following devices:

- ▶ TCSESM
- ▶ TCSESM-E

4.1 Variants of the ring/network coupling

In the **one-Switch coupling** configuration, the redundant coupling is performed by 2 ports **of one** device in the first ring/network coupled to 1 port each of 2 neighboring devices in a second ring/network segment (see [figure 20](#)). One of the lines, the redundant line, is blocked for normal traffic during normal operation.

When the main line becomes inoperable, the device immediately opens the redundant line. When the main line becomes functional again later, the redundant line is again blocked for normal traffic and the main line is used again.

The ring coupling detects and handles an error within 500 ms (typically 150 ms).

In the **two-Switch coupling** configuration, the redundant coupling is performed by 1 port each on **two** devices in the first ring/network to 1 port each of 2 neighboring devices in the second ring/network segment (see [figure 26](#)).

The device for the redundant line and the device for the main line use control packets to inform each other about their operating states, via the Ethernet or the control line.

When the main line becomes inoperable, the redundant device (called the slave) opens the redundant line. When the main line becomes functional again later, the device for the main line informs the redundant device. The redundant line is again blocked for normal traffic and the main line is used again.

The ring coupling detects and handles an error within 500 ms (typically 150 ms).

The type of coupling configuration is primarily determined by the topological conditions and the desired level of availability (see [table 8](#)).

	One-Switch coupling	Two-Switch coupling	Two-Switch coupling with control line
Application	The 2 devices are in impractical topological positions. Therefore, putting a line between them would involve a lot of effort for two-Switch coupling.	The 2 devices are in practical topological positions. Installing a control line would involve a lot of effort.	The 2 devices are in practical topological positions. Installing a control line would not involve much effort.
Disadvantage	If the Switch configured for the redundant coupling becomes inoperable, no connection remains between the networks.	More effort for connecting the 2 devices to the network (compared with one-Switch coupling).	More effort for connecting the two devices to the network (compared with one-Switch and two-Switch coupling).
Advantage	Less effort involved in connecting the 2 devices to the network (compared with two-Switch coupling).	If one of the devices configured for the redundant coupling becomes inoperable, the coupled networks are still connected.	If one of the devices configured for the redundant coupling becomes inoperable, the coupled networks are still connected.

Table 8: Selection criteria for the configuration types for redundant coupling

Note: Choose a configuration based on topological conditions and the level of availability you require ([see table 8](#)).

4.2 Preparing a Ring/Network Coupling

4.2.1 STAND-BY switch

All devices have a STAND-BY switch, with which you can define the role of the device within a Ring/Network coupling.

Depending on the device type, this switch is a DIP switch on the devices, or else it is exclusively a software setting (`Redundancy:Ring/Network Coupling` dialog). By setting this switch, you define whether the device has the main coupling or the redundant coupling role within a Ring/Network coupling. You will find details on the DIP switches in the “Installation” user manual.

Device type	STAND-BY switch type
TCSESM	Selectable: DIP switch and software setting
TCSESM-E	Software switch

Table 9: Overview of the STAND-BY switch types

Depending on the device and model, set the STAND-BY switch in accordance with the following table:

Device with	Choice of main coupling or redundant coupling
DIP switch	On "STAND-BY" DIP switch
DIP switch/software switch option	According to the option selected - on "STAND-BY" DIP switch or in the - Redundancy:Ring/Network Coupling dialog, by making selection in "Select configuration". Note: These devices have a DIP switch, with which you can choose between the software configuration and the DIP switch configuration. You can find details on the DIP switches in the User Manual Installation.
Software switch	In the Redundancy:Ring/Network Coupling dialog

Table 10: Setting the STAND-BY switch

Note: In the following screenshots and diagrams, the following conventions are used:

- ▶ Blue color denotes devices or lines in the current scope,
- ▶ black color denotes devices or lines adjacent to the current scope,
- ▶ thick lines denote lines in the current scope,
- ▶ thin lines denote lines adjacent to the current scope,
- ▶ the dashed line denotes the redundant link,
- ▶ the dotted line denotes the control line.

- Select the Redundancy:Ring/Network Coupling dialog.
- You first select the configuration you want: One-Switch coupling ("1"), two-Switch coupling ("2") or two-Switch coupling with control line ("3"), (see figure 19).

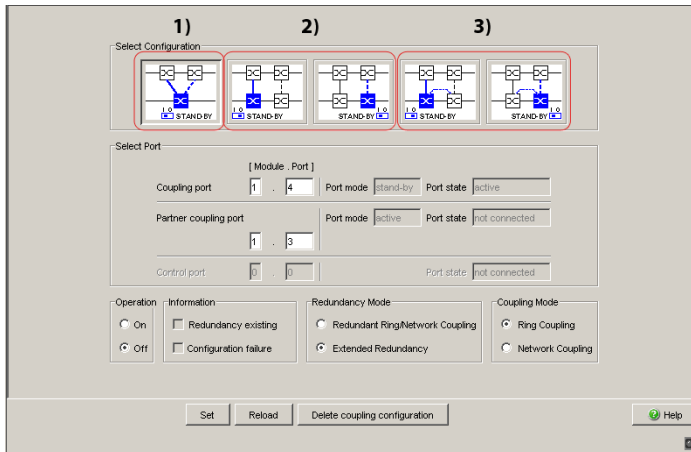

Figure 19: Choosing the ring coupling configuration (when the DIP switch is off, or for devices without a DIP switch)

For devices without DIP switches, the software settings are not restricted.

For devices **with** DIP switches, depending on the DIP switch position, the dialog displays the possible configurations in color, while those configurations that are not possible appear in gray.

The possible configurations are:

- ▶ DIP switch RM: ON or OFF, STAND-BY: OFF:
Two-Switch coupling as master (with or without control line)
- ▶ DIP switch RM: OFF, STAND-BY: ON:
One-Switch coupling and two-Switch coupling as slave (with or without control line)
- ▶ DIP switch RM: ON, STAND-BY: ON:
DIP switches are deactivated, and the software settings are possible without any restrictions

If the DIP switches are activated and you want to use the software to select one of the configurations that are not possible (grayed-out), you put the DIP switches on the device into another position and reload the dialog.

Note: For reasons of redundancy reliability, do not use Rapid Spanning Tree and Ring/Network Coupling in combination.

4.2.2 One-Switch coupling

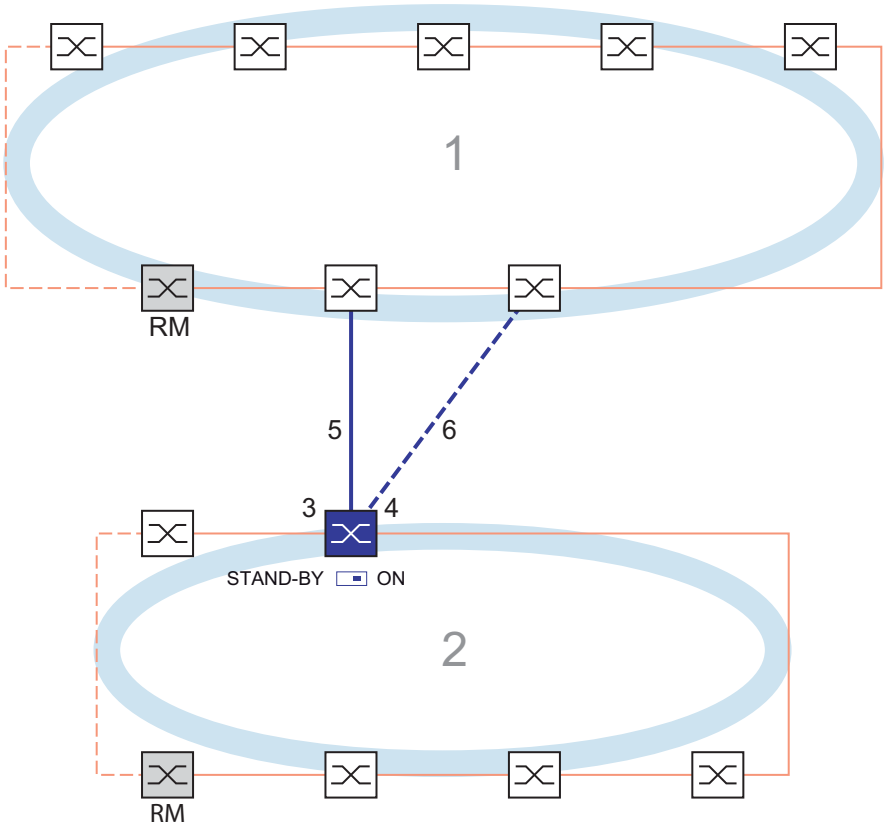

Figure 20: Example of one-Switch coupling

- 1: Backbone
- 2: Ring
- 3: Partner coupling port
- 4: Coupling port
- 5: Main Line
- 6: Redundant Line

⚠ WARNING

RING-/NETWORK COUPLING LOOP HAZARD

To avoid loops during the configuration phase, configure all the devices that participate actively in the Ring-/Network Coupling individually. Before you connect the redundant line, you must complete the configuration of all the devices that participate actively in the Ring-/Network Coupling.

Failure to follow these instructions can result in death, serious injury, or equipment damage.

The coupling between two networks is performed by the main line (solid blue line) in the normal mode of operation, which is connected to the partner coupling port. If the main line becomes inoperable, the redundant line (dashed blue line), which is connected to the coupling port, takes over the ring/network coupling. The coupling switch-over is performed by **one** Switch.

- Select the `Redundancy:Ring/Network Coupling` dialog.
- Select "One-Switch coupling" by means of the dialog button with the same graphic as below (see figure 21).

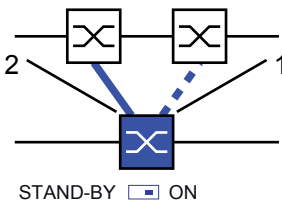

Figure 21: One-Switch-coupling
 1: Coupling port
 2: Partner coupling port

The following settings apply to the Switch displayed in blue in the selected graphic.

- Select the partner coupling port (see figure 22), (see table 11).
 With "Partner coupling port" you specify at which port you are connecting the main line.

The following tables show the selection options and default settings for the ports used in the Ring/Network coupling.

Device	Partner coupling port	Coupling port
TCSESM	All ports (default setting: port 1.3)	All ports (default setting: port 1.4)
TCSESM-E	All ports (default setting: port 1.3)	All ports (default setting: port 1.4)

Table 11: Port assignment for one-Switch coupling

Note: Configure the partner coupling port and the ring redundancy ports on different ports.

- Select the coupling port (see figure 22), (see table 11).
With “Coupling port” you specify to which port you connect the remote network segment.

Note: Configure the coupling port and the redundancy ring ports on different ports.

- Activate the function in the “Operation” frame (see figure 22).
- Now connect the redundant line.

The displays in the “Select port” frame mean (see figure 22):

- “Port mode”: The port is either active or in stand-by mode.
- “Port state”: The port is either connected or not connected.

The displays in the “Information” frame mean (see figure 22):

- “Redundancy existing”: If the main line becomes inoperable, the redundant line will then take over the function of the main line.
- “Configuration failure”: The function is incomplete or incorrectly configured.

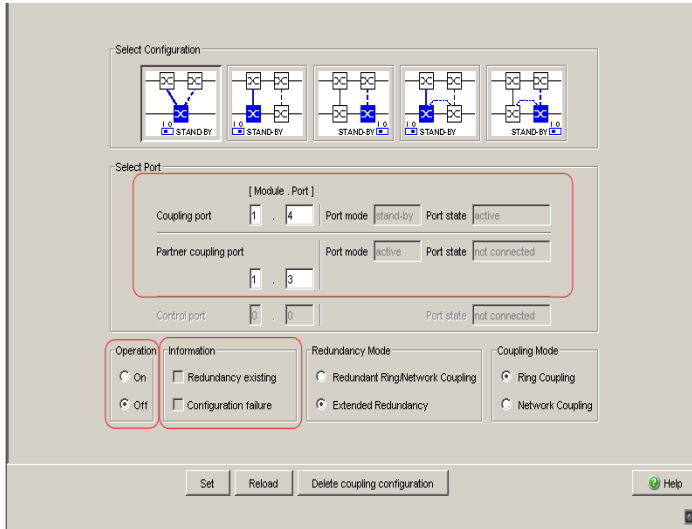

Figure 22: Selecting the port and enabling/disabling operation

Note: If VLANs are configured, set the coupling and partner coupling ports' VLAN configuration as follows:

- in the dialog `Switching:VLAN:Port` Port VLAN ID 1 and „Ingress Filtering“ deactivated
- in the dialog `Switching:VLAN:Static` VLAN-Membership U (Untagged)

Redundancy mode

- In the “Redundancy Mode” frame, select (see figure 23)
 - “Redundant Ring/Network Coupling” or
 - “Extended Redundancy”.

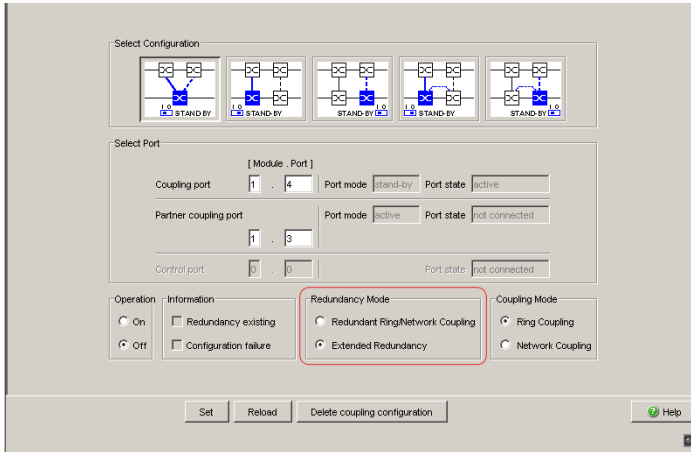

Figure 23: Selecting the redundancy mode

With the “Redundant Ring/Network Coupling” setting, either the main line or the redundant line is active. The lines are not both active at the same time.

With the “Extended Redundancy” setting, the main line and the redundant line are simultaneously active if the connection line between the devices in the connected (i.e., remote) network becomes inoperable (see figure 24). During the reconfiguration period, packet duplications may occur. Therefore, select this setting only if your application detects package duplications.

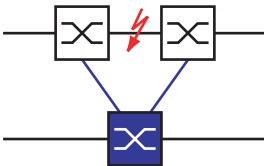

Figure 24: Extended redundancy

Coupling mode

The coupling mode indicates the type of the connected network.

- In the “Coupling Mode” frame, select (see figure 25)
 - “Ring Coupling” or
 - “Network Coupling”

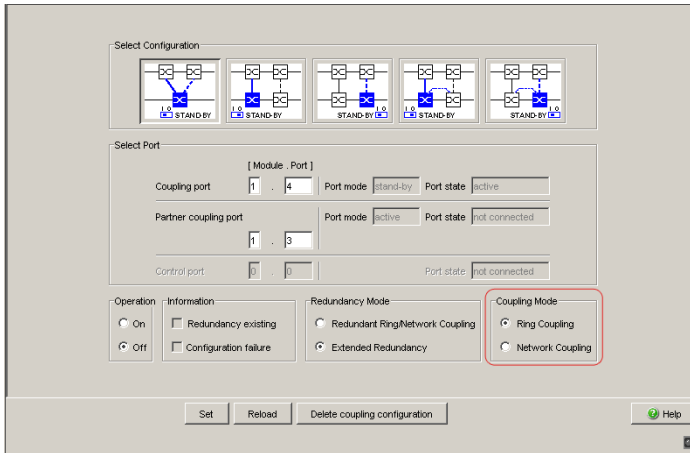

Figure 25: Selecting the coupling mode

- Select **"Ring coupling"** if you are connecting to a redundancy ring.
- Select **"Network Coupling"** if you are connecting to a line or tree structure.

Delete coupling configuration

- The “Delete coupling configuration” button in the dialog allows you to reset all the coupling settings of the device to the state on delivery.

4.2.3 Two-Switch coupling

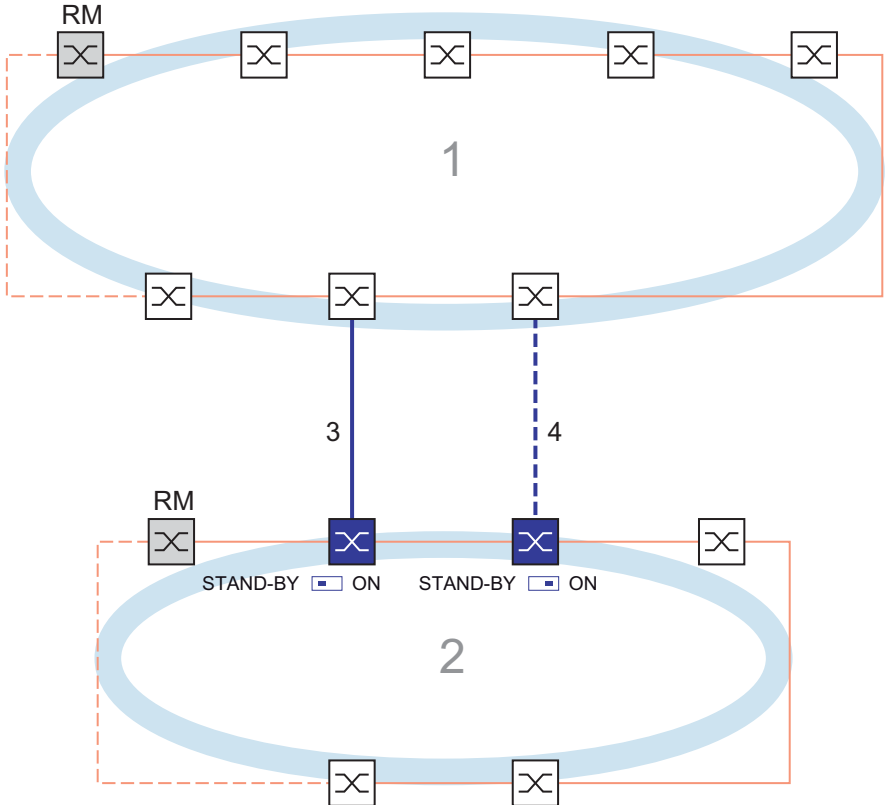

Figure 26: Example of two-Switch coupling

- 1: Backbone
- 2: Ring
- 3: Main line
- 4: Redundant line

⚠ WARNING

RING-/NETWORK COUPLING LOOP HAZARD

To avoid loops during the configuration phase, configure all the devices that participate actively in the Ring-/Network Coupling individually. Before you connect the redundant line, you must complete the configuration of all the devices that participate actively in the Ring-/Network Coupling.

Failure to follow these instructions can result in death, serious injury, or equipment damage.

The coupling between 2 networks is performed by the main line (solid blue line). If the main line or one of the adjacent Switches becomes inoperable, the redundant line (dashed black line) takes over coupling the 2 networks. The coupling is performed by two Switches.

The switches send their control packages over the Ethernet.

The Switch connected to the main line, and the Switch connected to the redundant line are partners with regard to the coupling.

- Connect the two partners via their ring ports.

- Select the `Redundancy:Ring/Network Coupling` dialog.
- Select "Two-Switch coupling" by means of the dialog button with the same graphic as below (see figure 27).

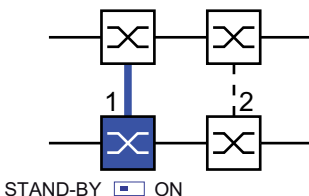

Figure 27: Two-Switch coupling
 1: Coupling port
 2: Partner coupling port

The following settings apply to the Switch displayed in blue in the selected graphic.

- Select the coupling port (see figure 28), (see table 12)..
With “Coupling port” you specify to which port you connect the remote network segment.
- For a device with DIP switches, you switch the STAND-BY switch to OFF or deactivate the DIP switches. Connect the main line to the coupling port.

Device	Coupling port
TCSESM	Adjustable for all ports (default setting: port 1.4)
TCSESM-E	Adjustable for all ports (default setting: port 1.4)

Table 12: Port assignment for the redundant coupling (two-Switch coupling)

Note: Configure the coupling port and the redundancy ring ports on different ports.

- Activate the function in the “Operation” frame (see figure 28).
- Now connect the redundant line.
The displays in the “Select port” frame mean (see figure 28):
 - “Port mode”: The port is either active or in stand-by mode.
 - “Port state”: The port is either connected or not connected.
 - “IP Address”: The IP address of the partner, if the partner is already operating in the network.
- The displays in the “Information” frame mean (see figure 28):
 - “Redundancy existing”: If the main line becomes inoperable, the redundant line will then take over the function of the main line.
 - “Configuration failure”: The function is incomplete or incorrectly configured.

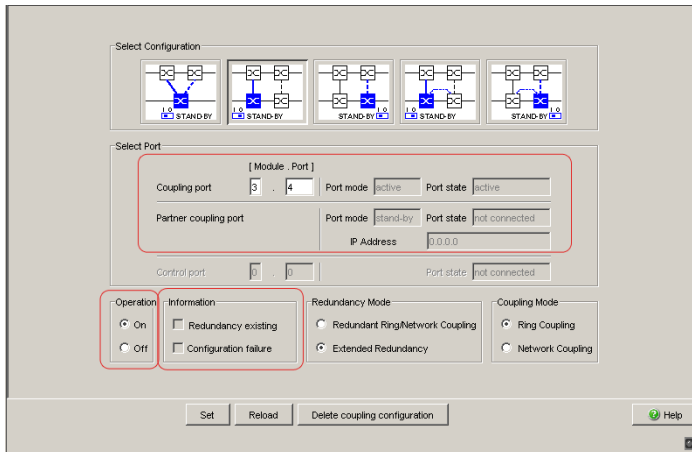

Figure 28: Selecting the port and enabling/disabling operation

To avoid continuous loops, the Switch sets the port state of the coupling port to “off” if you:

- switch off the operation setting or
- change the configuration

while the connections are in operation at these ports.

Note: The following settings are required for the coupling ports (you select the **Basic Settings:Port Configuration** dialog):

- Port: on
- Automatic configuration (autonegotiation):
on for twisted-pair connections
- Manual configuration: 100 Mbit/s FDX, or 1 Gbit/s FDX, according to the port’s capabilities
for glass fiber connections

Note: If VLANs are configured, set the coupling and partner coupling ports’ VLAN configuration as follows:

- in the dialog **Switching:VLAN:Port** Port VLAN ID 1 and „Ingress Filtering“ deactivated
- in the dialog **Switching:VLAN:Static VLAN-Membership U** (Untagged)

Note: If you are operating the Ring Manager and two-Switch coupling functions at the same time, there is the possibility of creating a loop.

- Select "Two-Switch coupling" by means of the dialog button with the same graphic as below (see figure 29).

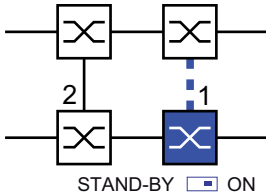

Figure 29: Two-Switch coupling
 1: Coupling port
 2: Partner coupling port

The following settings apply to the Switch displayed in blue in the selected graphic.

- Select the coupling port (see figure 28), (see table 12).
 With "Coupling port" you specify to which port you connect the remote network segment.
- For a device with DIP switches, you switch the STAND-BY switch to ON or deactivate the DIP switches. You connect the redundant line to the coupling port.

Note: Configure the coupling port and the redundancy ring ports on different ports.

- Activate the function in the "Operation" frame (see figure 28).
 The displays in the "Select port" frame mean (see figure 28):
 - "Port mode": The port is either active or in stand-by mode.
 - "Port state": The port is either connected or not connected.
 - "IP Address": The IP address of the partner, if the partner is already operating in the network.

The displays in the “Information” frame mean (see figure 28):

- “Redundancy existing”: If the main line becomes inoperable, the redundant line will then take over the function of the main line.
- “Configuration failure”: The function is incomplete or incorrectly configured.

To avoid continuous loops, the Switch sets the port state of the coupling port to “off” if you::

- switch off operation or
- change the configuration

while the connections are in operation at these ports.

Note: The following settings are required for the coupling ports (you select the `Basic Settings:Port Configuration` dialog):

- Port: on
- Automatic configuration (autonegotiation):
on for twisted-pair connections
- Manual configuration: 100 Mbit/s FDX, or 1 Gbit/s FDX, according to the port’s capabilities
for glass fiber connections

Note: If VLANs are configured, set the coupling and partner coupling ports’ VLAN configuration as follows:

- in the dialog `Switching:VLAN:Port Port VLAN ID 1` and „Ingress Filtering“ deactivated
- in the dialog `Switching:VLAN:Static VLAN-Membership U (Untagged)`

Note: If you are operating the Ring Manager and two-Switch coupling functions at the same time, there is the possibility of creating a loop.

Redundancy mode

- In the “Redundancy Mode” frame, select (see figure 30)
- “Redundant Ring/Network Coupling” or
- “Extended Redundancy”.

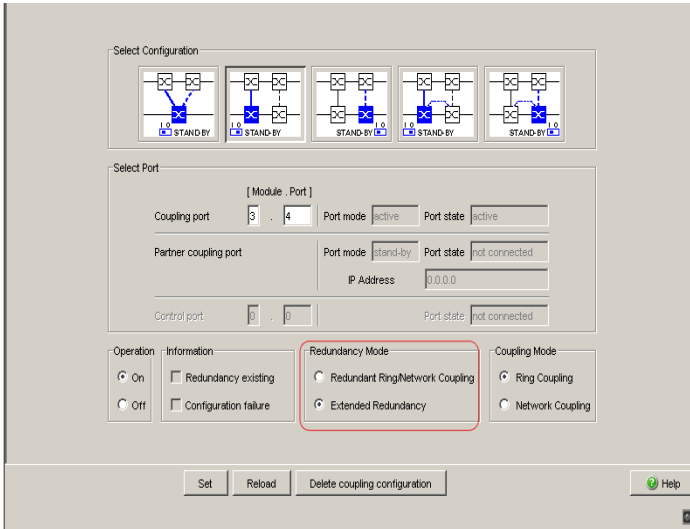

Figure 30: Selecting the redundancy mode

With the "Redundant Ring/Network Coupling" setting, either the main line or the redundant line is active. The lines are not both active at the same time.

With the "Extended Redundancy" setting, the main line and the redundant line are simultaneously active if the connection line between the devices in the connected (i.e., remote) network becomes inoperable (see figure 31). During the reconfiguration period, packet duplications may occur. Therefore, select this setting only if your application detects package duplications.

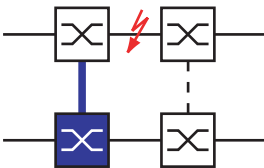

Figure 31: Extended redundancy

Coupling mode

The coupling mode indicates the type of the connected network.

- In the “Coupling Mode” frame, select (see figure 32)
 - “Ring Coupling” or
 - “Network Coupling”

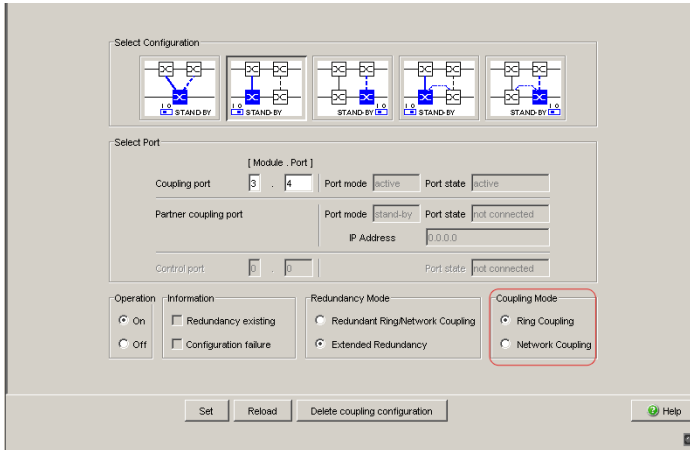

Figure 32: Selecting the coupling mode

- Select **"Ring coupling"** if you are connecting to a redundancy ring.
- Select **"Network Coupling"** if you are connecting to a line or tree structure.

Delete coupling configuration

- The “Delete coupling configuration” button in the dialog allows you to reset all the coupling settings of the device to the state on delivery.

4.2.4 Two-Switch Coupling with Control Line

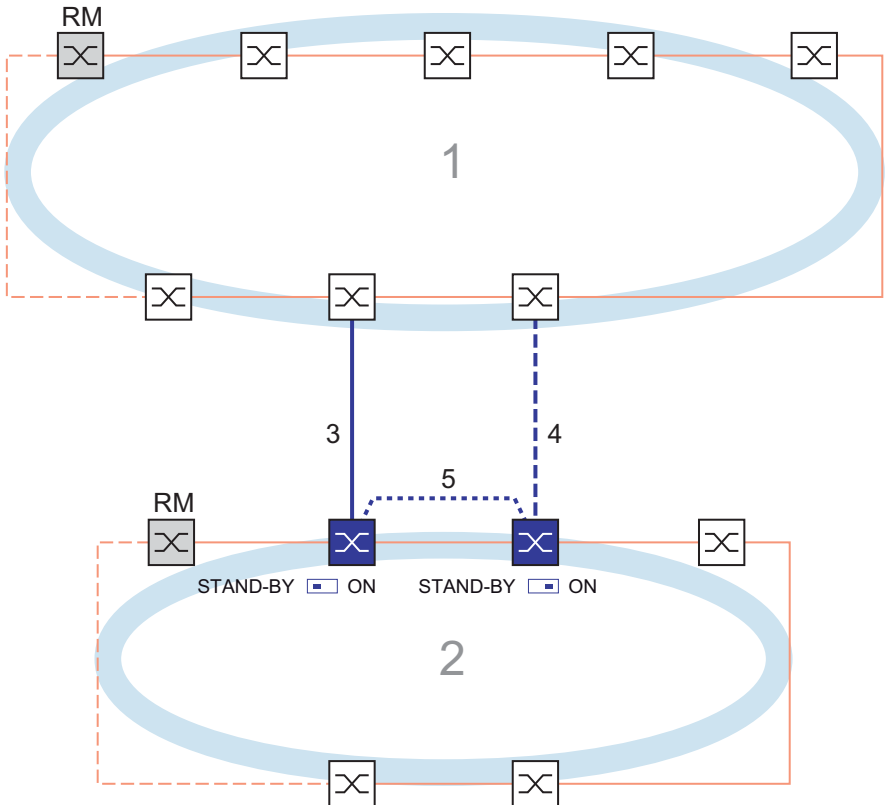

Figure 33: Example of Two-Switch coupling with control line

- 1: Backbone
- 2: Ring
- 3: Main line
- 4: Redundant line
- 5: Control line

⚠ WARNING

RING-/NETWORK COUPLING LOOP HAZARD

To avoid loops during the configuration phase, configure all the devices that participate actively in the Ring-/Network Coupling individually. Before you connect the redundant line, you must complete the configuration of all the devices that participate actively in the Ring-/Network Coupling.

Failure to follow these instructions can result in death, serious injury, or equipment damage.

The coupling between 2 networks is performed by the main line (solid blue line). If the main line or one of the adjacent Switches becomes inoperable, the redundant line (dashed black line) takes over coupling the 2 networks. The coupling is performed by two Switches.

The Switches send their control packets over a control line (dotted line). The Switch connected to the main line, and the Switch connected to the redundant line are partners with regard to the coupling.

- Connect the two partners via their ring ports.

- Select the `Redundancy:Ring/Network Coupling` dialog.
- Select „Two-Switch coupling with control line“ by means of the dialog button with the same graphic as below (see figure 34).

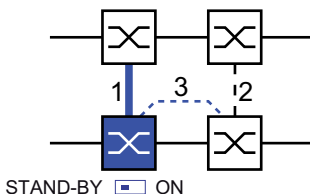

Figure 34: Two-Switch coupling with control line

- 1: Coupling port
- 2: Partner coupling port
- 3: Control line

The following settings apply to the Switch displayed in blue in the selected graphic.

- Select the coupling port (see figure 35), (see table 13).
With “Coupling port” you specify to which port you connect the remote network segment.
- For a device with DIP switches, you switch the STAND-BY switch to OFF or deactivate the DIP switches. Connect the main line to the coupling port.
- Select the control port (see figure 35), (see table 13).
With “Control port” you specify to which port you connect the control line.

Device	Coupling port	Control port
TCSESM	Adjustable for all ports (default setting: port 1.4)	Adjustable for all ports (default setting: port 1.3)
TCSESM-E	Adjustable for all ports (default setting: port 1.4)	Adjustable for all ports (default setting: port 1.3)

Table 13: Port assignment for the redundant coupling (two-Switch coupling with control line)

Note: Configure the coupling port and the redundancy ring ports on different ports.

- Activate the function in the “Operation” frame (see figure 35).
 - Now connect the redundant line and the control line.
- The displays in the “Select port” frame mean (see figure 35):
- “Port mode”: The port is either active or in stand-by mode.
 - “Port state”: The port is either connected or not connected.
 - “IP Address”: The IP address of the partner, if the partner is already operating in the network.

The displays in the “Information” frame mean (see figure 35)

- “Redundancy existing”: If the main line becomes inoperable, the redundant line will then take over the function of the main line.
- “Configuration failure”: The function is incomplete or incorrectly configured.

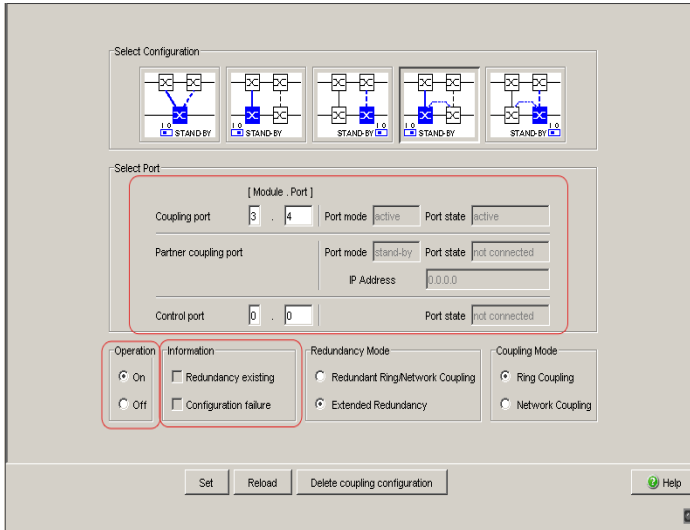

Figure 35: Selecting the port and enabling/disabling operation

To avoid continuous loops, the Switch sets the port state of the coupling port to “off” if you:

- switch off the operation setting or
- change the configuration

while the connections are in operation at these ports.

Note: The following settings are required for the coupling ports (you select the Basic Settings:Port Configuration dialog):

- Port: on
- Automatic configuration (autonegotiation): on for twisted-pair connections
- Manual configuration: 100 Mbit/s FDX, or 1 Gbit/s FDX, according to the port’s capabilities for glass fiber connections

Note: If VLANs are configured, set the coupling and partner coupling ports' VLAN configuration as follows:

- in the dialog `Switching:VLAN:Port` Port VLAN ID 1 and „Ingress Filtering“ deactivated
- in the dialog `Switching:VLAN:Static` VLAN-Membership U (Untagged)

- Select "Two-Switch coupling with control line" by means of the dialog button with the same graphic as below (see figure 36).

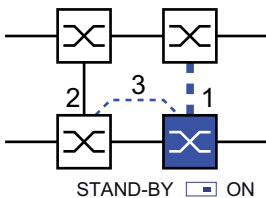

Figure 36: Two-Switch coupling with control line

- 1: Coupling port
- 2: Partner coupling port
- 3: Control line

The following settings apply to the Switch displayed in blue in the selected graphic.

- Select the coupling port (see figure 35), (see table 13).
With "Coupling port" you specify to which port you connect the remote network segment.
- For a device with DIP switches, you switch the STAND-BY switch to ON or deactivate the DIP switches. You connect the redundant line to the coupling port.
- Select the control port (see figure 35), (see table 13).
With "Control port" you specify to which port you connect the control line.

Note: Configure the coupling port and the redundancy ports on different ports.

- Activate the function in the "Operation" frame (see figure 35).

- Now connect the redundant line and the control line.

The displays in the “Select port” frame mean (see figure 35):

- “Port mode”: The port is either active or in stand-by mode.
- “Port state”: The port is either connected or not connected.
- “IP Address”: The IP address of the partner, if the partner is already operating in the network.

The displays in the “Information” frame mean (see figure 35):

- “Redundancy existing”: If the main line becomes inoperable, the redundant line will then take over the function of the main line.
- “Configuration failure”: The function is incomplete or incorrectly configured.

To avoid continuous loops, the Switch sets the port state of the coupling port to “off” if you:

- switch off the operation setting or
- change the configuration

while the connections are in operation at these ports.

Note: The following settings are required for the coupling ports (you select the `Basic Settings:Port Configuration` dialog):

- Port: on
- Automatic configuration (autonegotiation):
on for twisted-pair connections
- Manual configuration: 100 Mbit/s FDX, or 1 Gbit/s FDX, according to the port’s capabilities
for glass fiber connections

Note: If VLANs are configured, set the coupling and partner coupling ports’ VLAN configuration as follows:

- in the dialog `Switching:VLAN:Port Port VLAN ID 1` and „Ingress Filtering“ deactivated
- in the dialog `Switching:VLAN:Static VLAN-Membership U (Untagged)`

Redundancy mode

- In the “Redundancy Mode” frame, select (see figure 37)
 - “Redundant Ring/Network Coupling” or
 - “Extended Redundancy”.

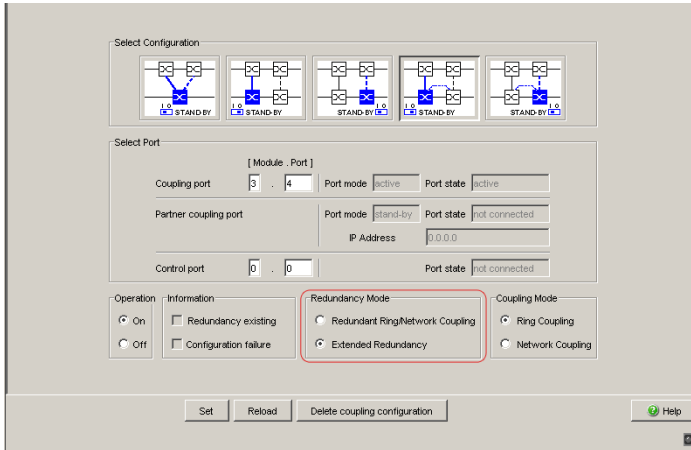

Figure 37: Selecting the redundancy mode

With the “Redundant Ring/Network Coupling” setting, either the main line or the redundant line is active. The lines are not both active at the same time.

With the “Extended Redundancy” setting, the main line and the redundant line are simultaneously active if the connection line between the devices in the connected (i.e., remote) network becomes inoperable (see figure 38). During the reconfiguration period, packet duplications may occur. Therefore, select this setting only if your application detects package duplications.

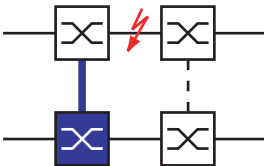

Figure 38: Extended redundancy

Coupling mode

The coupling mode indicates the type of the connected network.

- In the “Coupling Mode” frame, select (see figure 39)
 - “Ring Coupling” or
 - “Network Coupling”

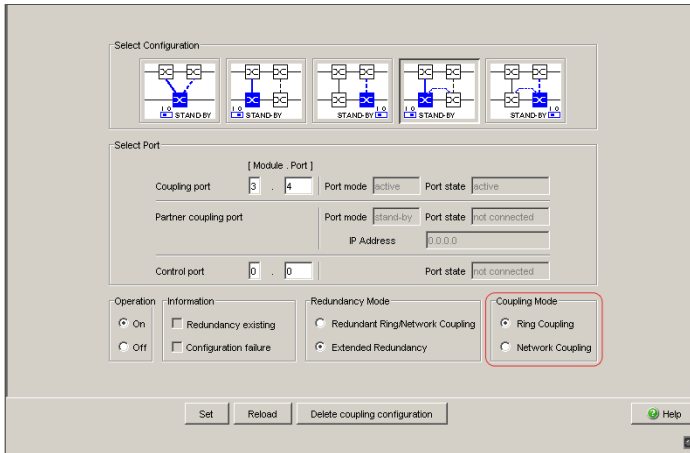

Figure 39: Selecting the coupling mode

- Select **"Ring coupling"** if you are connecting to a redundancy ring.
- Select **"Network Coupling"** if you are connecting to a line or tree structure.

Delete coupling configuration

- The “Delete coupling configuration” button in the dialog allows you to reset all the coupling settings of the device to the state on delivery.

5 Spanning Tree

Note: The Spanning Tree Protocol is a protocol for MAC bridges. For this reason, the following description uses the term bridge for Switch.

Local networks are getting bigger and bigger. This applies to both the geographical expansion and the number of network participants. Therefore, it is advantageous to use multiple bridges, for example:

- ▶ to reduce the network load in sub-areas,
- ▶ to set up redundant connections and
- ▶ to overcome distance limitations.

However, using multiple bridges with multiple redundant connections between the subnetworks can lead to loops and thus loss of communication across of the network. In order to help avoid this, you can use Spanning Tree. Spanning Tree enables loop-free switching through the systematic deactivation of redundant connections. Redundancy enables the systematic reactivation of individual connections as needed.

RSTP is a further development of the Spanning Tree Protocol (STP) and is compatible with it. If a connection or a bridge becomes inoperable, the STP required a maximum of 30 seconds to reconfigure. This is no longer acceptable in time-sensitive applications. RSTP achieves average reconfiguration times of less than a second. When you use RSTP in a ring topology with 10 to 20 devices, you can even achieve reconfiguration times in the order of milliseconds.

Note: RSTP reduces a layer 2 network topology with redundant paths into a tree structure (Spanning Tree) that does not contain any more redundant paths. One of the Switches takes over the role of the root bridge here. The maximum number of devices permitted in an active branch (from the root bridge to the tip of the branch) is specified by the variable `Max Age` for the current root bridge. The preset value for `Max Age` is 20, which can be increased up to 40.

If the device working as the root is inoperable and another device takes over its function, the `Max Age` setting of the new root bridge determines the maximum number of devices allowed in a branch.

Note: The RSTP Standard dictates that all the devices within a network work with the (Rapid) Spanning Tree Algorithm. However, if STP and RSTP are used at the same time, the advantages of faster reconfiguration with RSTP are lost.

Note: By changing the IEEE 802.1D-2004 standard for RSTP, the Standards Commission reduced the maximum value for the “Hello Time” from 10 s to 2 s. When you update the Switch software from a release before 5.0 to release 5.0 or higher, the new software release automatically reduces the locally entered “Hello Time” values that are greater than 2 s to 2 s. If the device is not the RSTP root, “Hello Time” values greater than 2 s can remain valid, depending on the software release of the root device.

5.1 The Spanning Tree Protocol

Because RSTP is a further development of the STP, all the following descriptions of the STP also apply to the RSTP.

5.1.1 The tasks of the STP

The Spanning Tree Algorithm reduces network topologies built with bridges and containing ring structures due to redundant links to a tree structure. In doing so, STP opens ring structures according to preset rules by deactivating redundant paths. If a path is interrupted because a network component becomes inoperable, STP reactivates the previously deactivated path again. This allows redundant links to increase the availability of communication. STP determines a bridge that represents the STP tree structure's base. This bridge is called root bridge.

Features of the STP algorithm:

- ▶ automatic reconfiguration of the tree structure in the case of a bridge becoming inoperable or the interruption of a data path
- ▶ the tree structure is stabilized up to the maximum network size (up to 39 hops, depending on the setting for `Max Age`, [\(see table 16\)](#))
- ▶ stabilization of the topology within a short time period
- ▶ topology can be specified and reproduced by the administrator
- ▶ transparency for the terminal devices
- ▶ low network load relative to the available transmission capacity due to the tree structure created

5.1.2 Bridge parameters

In the context of Spanning Tree, each bridge and its connections are uniquely described by the following parameters:

- ▶ Bridge Identifier
- ▶ Root Path Cost for the bridge ports,
- ▶ Port Identifier

5.1.3 Bridge Identifier

The Bridge Identifier consists of 8 bytes. The 2 highest-value bytes are the priority. The default setting for the priority number is 32,768, but the Management Administrator can change this when configuring the network. The 6 lowest-value bytes of the bridge identifier are the bridge's MAC address. The MAC address allows each bridge to have unique bridge identifiers.

The bridge with the smallest number for the bridge identifier has the highest priority.

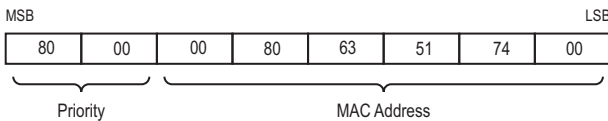

Figure 40: Bridge Identifier, Example (values in hexadecimal notation)

5.1.4 Root Path Cost

Each path that connects 2 bridges is assigned a cost for the transmission (path cost). The Switch determines this value based on the transmission speed (see table 14). It assigns a higher path cost to paths with lower transmission speeds.

Alternatively, the Administrator can set the path cost. Like the Switch, the Administrator assigns a higher path cost to paths with lower transmission speeds. However, since the Administrator can choose this value freely, he has a tool with which he can give a certain path an advantage among redundant paths.

The root path cost is the sum of all individual costs of those paths that a data packet has to traverse from a connected bridge's port to the root bridge.

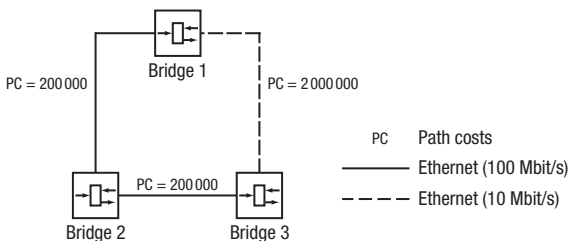

Figure 41: Path costs

Data rate	Recommended value	Recommended range	Possible range
<=100 kbit/s	20,000,000 ^a	20,000,000-200,000,000	1-200,000,000
1 Mbit/s	2,000,000 ^a	2,000,000-200,000,000	1-200,000,000
10 Mbit/s	2,000,000 ^a	200,000-20,000,000	1-200,000,000
100 Mbit/s	200,000 ^a	20,000-2,000,000	1-200,000,000
1 Gbit/s	20,000	2,000-200,000	1-200,000,000
10 Gbit/s	2,000	200-20,000	1-200,000,000
100 Gbit/s	200	20-2,000	1-200,000,000
1 Tbit/s	20	2-200	1-200,000,000
10 Tbit/s	2	1-20	1-200,000,000

Table 14: Recommended path costs for RSTP based on the data rate.

- a. Bridges conforming to IEEE 802.1D-1998 that only support 16-bit values for path costs should use the value 65,535 for path costs when they are used in conjunction with bridges that support 32-bit values for the path costs.

5.1.5 Port Identifier

The port identifier consists of 2 bytes. One part, the lower-value byte, contains the physical port number. This provides a unique identifier for the port of this bridge. The second, higher-value part is the port priority, which is specified by the Administrator (default value: 128). It also applies here that the port with the smallest number for the port identifier has the highest priority.

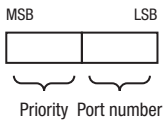

Figure 42: Port Identifier

5.2 Rules for Creating the Tree Structure

5.2.1 Bridge information

To determine the tree structure, the bridges need more detailed information about the other bridges located in the network.

To obtain this information, each bridge sends a BPDU (Bridge Protocol Data Unit) to the other bridges.

The contents of a BPDU include

- ▶ bridge identifier,
- ▶ root path cost and
- ▶ port identifier

(see IEEE 802.1D).

5.2.2 Setting up the tree structure

- ▶ The bridge with the smallest number for the bridge identifier is called the root bridge. It is (or will become) the root of the tree structure.
- ▶ The structure of the tree depends on the root path costs. Spanning Tree selects the structure so that the path costs between each individual bridge and the root bridge become as small as possible.

- ▶ If there are multiple paths with the same root path costs, the bridge further away from the root decides which port it blocks. For this purpose, it uses the bridge identifiers of the bridge closer to the root. The bridge blocks the port that leads to the bridge with the numerically higher ID (a numerically higher ID is the logically worse one). If 2 bridges have the same priority, the bridge with the numerically larger MAC address has the numerically higher ID, which is logically the worse one.
- ▶ If multiple paths with the same root path costs lead from one bridge to the same bridge, the bridge further removed from the root uses the port identifier of the other bridge as the last criterion (see figure 42). In the process, the bridge blocks the port that leads to the port with the numerically higher ID (a numerically higher ID is the logically worse one). If 2 ports have the same priority, the port with the higher port number has the numerically higher ID, which is logically the worse one.

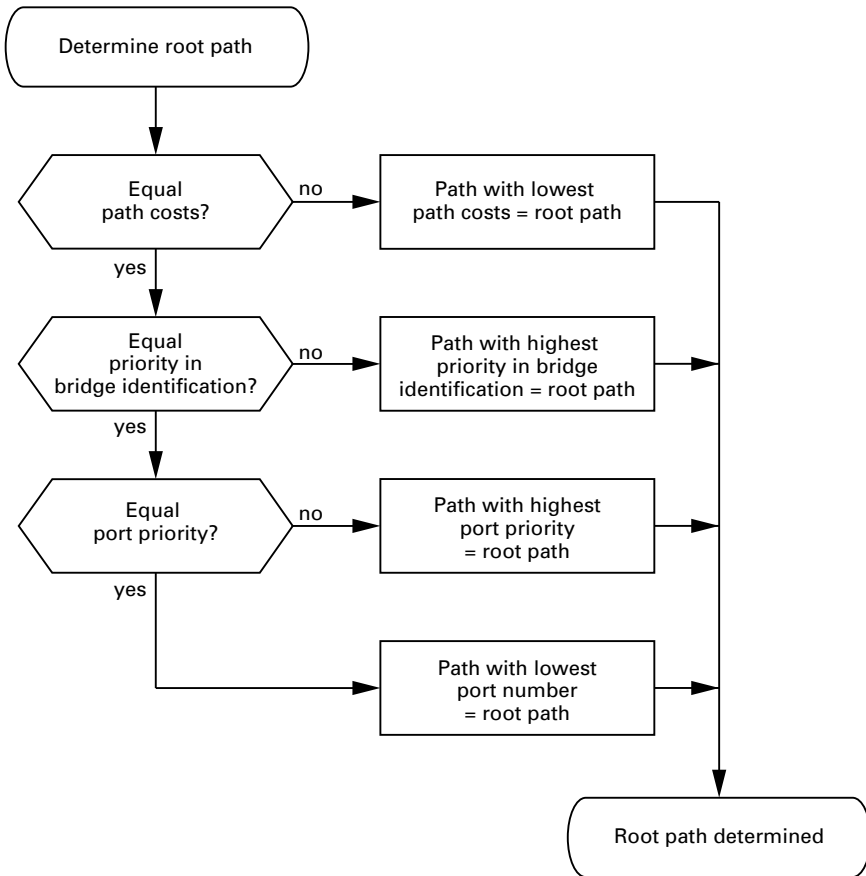

Figure 43: Flow diagram for specifying the root path

5.3 Example of Root Path Determination

The network plan (see figure 44) can be used to create the flow diagram (see figure 43) for defining the root path. The Administrator has defined a different priority for each bridge's bridge identifier. The bridge with the smallest number for the bridge identifier will become the root bridge, in this case bridge 1. In the example, all the sub-paths have the same path costs. The path between bridge 2 and bridge 3 is blocked, because a connection from bridge 3 to the root bridge via bridge 2 has a higher path cost.

The path from bridge 6 to the root bridge is interesting:

- ▶ The path via bridge 5 and bridge 3 create the same root path costs as the path via bridge 4 and bridge 2.
- ▶ The path via bridge 4 is selected because the value 28,672 for its priority in the bridge identifier is smaller than value 32,768.
- ▶ However, there are also 2 paths between bridge 6 and bridge 4. The port identifier is decisive here.

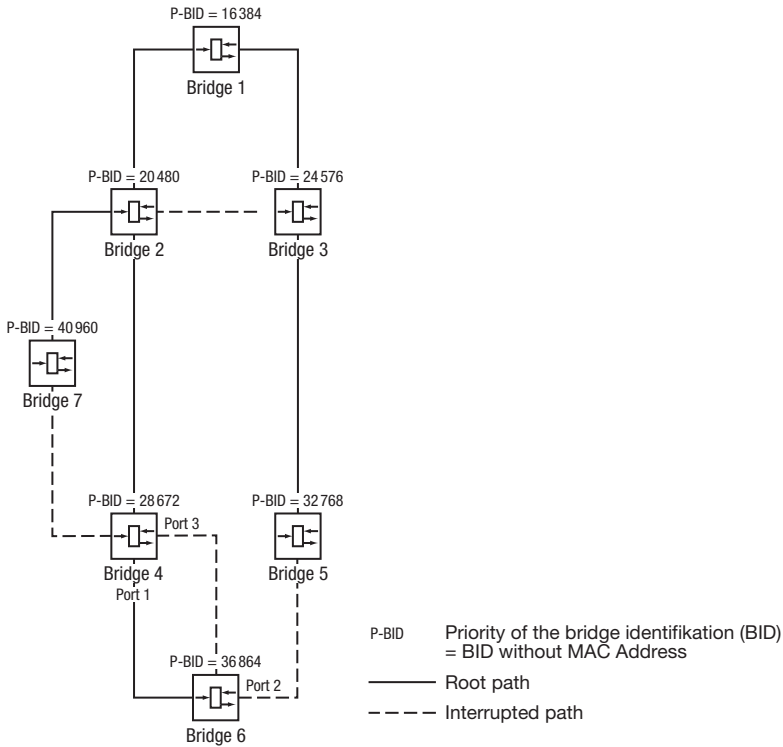

Figure 44: Example of root path determination

5.4 Example of Root Path Manipulation

The network plan (see figure 44) can be used to create the flow diagram (see figure 43) for defining the root path. The Administrator – left the default value of 32,768 for each bridge except for bridge 1, – bridge 1 value was set to 16,384, thus making it the root bridge. In the example, all the sub-paths have the same path costs. The path between bridge 2 and bridge 3 is blocked by the protocol because a connection from bridge 3 to the root bridge via bridge 2 has a higher path cost.

The path from bridge 6 to the root bridge is interesting:

- ▶ The path via bridge 5 and bridge 3 creates the same root path costs as the path via bridge 4 and bridge 2.
- ▶ STP selects the path using the bridge that has the lowest MAC address in the bridge identification (bridge 4 in the illustration).
- ▶ However, there are also 2 paths between bridge 6 and bridge 4. The port identifier is decisive here.

Note: Because the Administrator does not change the default values for the priorities of the bridges in the bridge identifier, apart from the value for the root bridge, the MAC address in the bridge identifier alone determines which bridge becomes the new root bridge if the root bridge becomes inoperable.

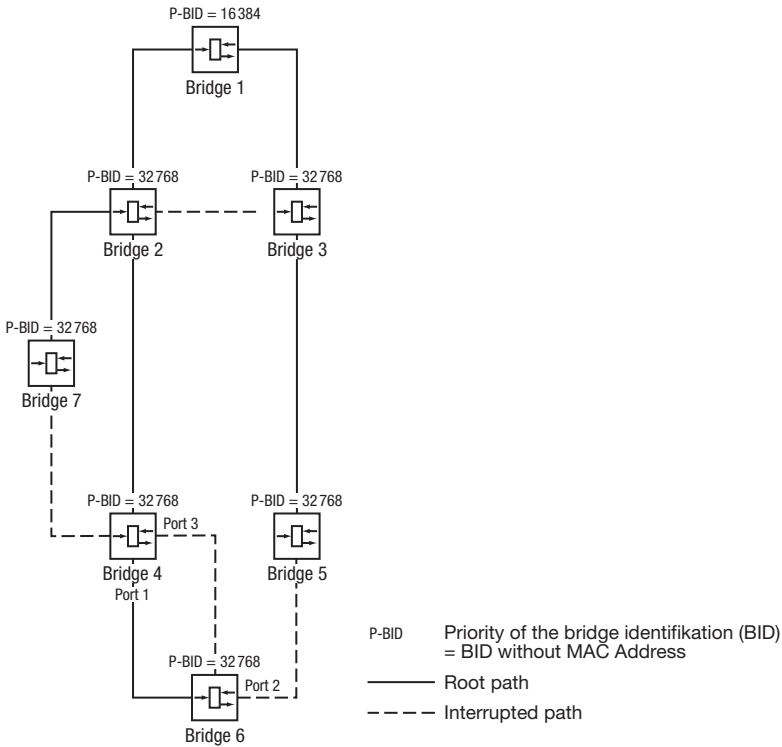

Figure 45: Example of root path manipulation

5.5 Example of Tree Structure Manipulation

The Management Administrator soon discovers that this configuration with bridge 1 as the root bridge (see on page 91 “[Example of Root Path Determination](#)”) is unfavorable. On the paths from bridge 1 to bridge 2 and bridge 1 to bridge 3, the control packets which the root bridge sends to all other bridges are adding up. If the Management Administrator makes bridge 2 the root bridge, the burden of the control packets on the subnetworks is distributed much more evenly. The result is the configuration shown here (see figure 46). The distances between the individual bridges and the root bridge are now shorter.

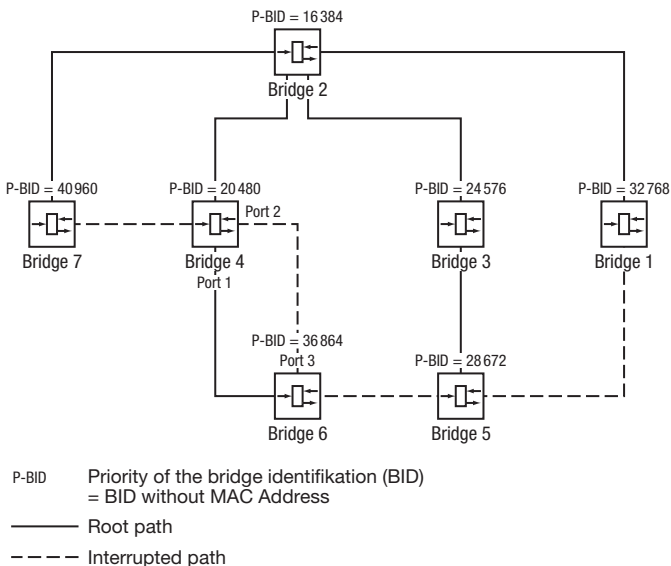

Figure 46: Example of tree structure manipulation

5.6 The Rapid Spanning Tree Protocol

The RSTP uses the same algorithm for determining the tree structure as STP. RSTP merely changes parameters, and adds new parameters and mechanisms that speed up the reconfiguration if a link or bridge becomes inoperable.

The ports play a significant role in this context.

5.6.1 Port roles

RSTP assigns each bridge port one of the following roles ([see figure 47](#)):

- ▶ **Root port**
This is the port on which a bridge receives data packets with the lowest path costs from the root bridge.
If there is more than 1 port with the same low path costs, the bridge identifier determines which port is the root port.
If there is more than 1 port with the same low path costs connected to the same bridge, the port identifier determines which port is the root port ([see figure 43](#)).
The root bridge itself does not have a root port.
- ▶ **Designated port**
The bridge in a network segment that has the lowest root path costs is the designated bridge. If more than 1 bridge has the same root path costs, the bridge with the smallest value bridge identifier becomes the designated bridge. The port on this bridge that connects it to a network segment leading to the root bridge, is the designated port.

- ▶ **Edge port**
Every network segment with no additional RSTP bridges is connected with exactly one designated port. In this case, this designated port is also an edge port. The distinction of an edge port is the fact that it does not receive any RST BPDUs (Rapid Spanning Tree Bridge Protocol Data Units).
- ▶ **Alternate port**
This is a blocked port that takes over the task of the bridge port if the connection to the root bridge is lost. The alternate port provides a backup connection to the root bridge.
- ▶ **Backup port**
This is a blocked port that serves as a backup in case the connection to the designated port of this network segment (without any RSTP bridges) is lost
- ▶ **Disabled port**
This is a port that does not participate in the Spanning Tree Operation, i.e., the port is switched off or does not have any connection.

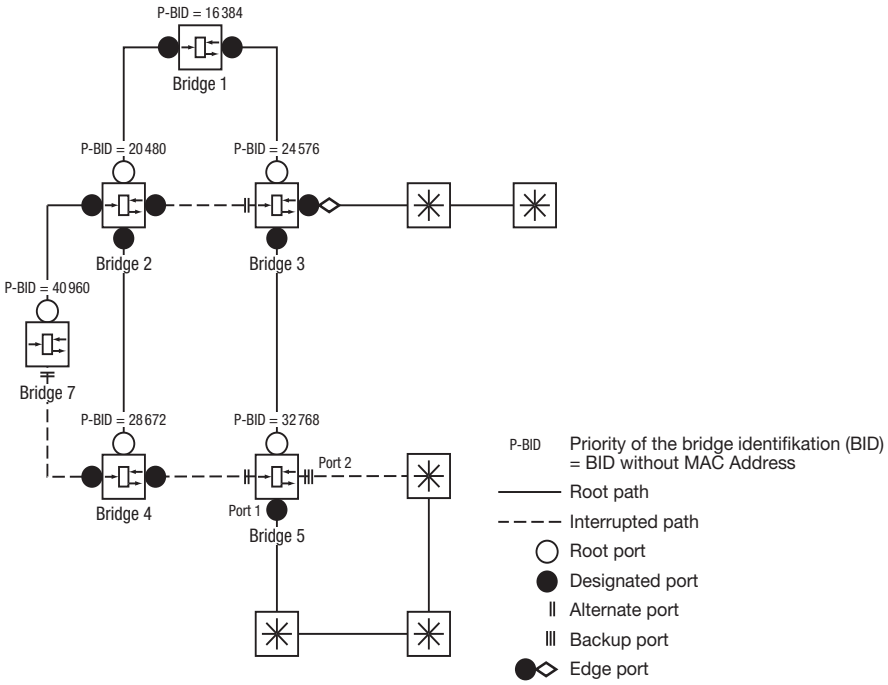

Figure 47: Port role assignment

5.6.2 Port states

Depending on the tree structure and the state of the selected connection paths, the RSTP assigns the ports their states.

STP port state	Administrative bridge port state	MAC operational	RSTP Port state	Active topology (port role)
DISABLED	Disabled	FALSE	Discarding ^a	Excluded (disabled)
DISABLED	Enabled	FALSE	Discarding ^a	Excluded (disabled)
BLOCKING	Enabled	TRUE	Discarding ^b	Excluded (alternate, backup)
LISTENING	Enabled	TRUE	Discarding ^b	Included (root, designated)
LEARNING	Enabled	TRUE	Learning	Included (root, designated)
FORWARDING	Enabled	TRUE	Forwarding	Included (root, designated)

Table 15: Relationship between port state values for STP and RSTP

- a. The dot1d MIB shows "Disabled"
- b. The dot1d MIB shows "Blocked"

Meaning of the RSTP port states:

- ▶ Disabled: port does not belong to the active topology
- ▶ Discarding: no address learning in FDB, no data traffic except BPDUs
- ▶ Learning: address learning active (FDB), no data traffic except BPDUs
- ▶ Forwarding: address learning active (FDB), sending and receiving of all frame types (not only BPDUs)

5.6.3 Spanning Tree Priority Vector

To assign roles to the ports, the RSTP bridges exchange configuration information with each other. This information is known as the Spanning Tree Priority Vector. It is part of the RST BPDUs and contains the following information:

- ▶ Bridge identifier of the root bridge
- ▶ Root path costs for the sending bridge
- ▶ Bridge identifier for the sending bridge
- ▶ Port identifiers of the port through which the message was sent
- ▶ Port identifiers of the port that has received the message

Based on this information, the bridges participating in RSTP are able to determine port roles autonomously and define their local ports' states.

5.6.4 Fast reconfiguration

Why can RSTP react faster than STP to an interruption of the root path?

- ▶ Introduction of edge ports:
During a reconfiguration, RSTP sets an edge port to the transmission mode after 3 seconds and then waits for the "Hello Time" (see table 16) to elapse, to ascertain that no BPDU-sending bridge is connected. When the user ascertains that a terminal device is connected at this port and will remain connected, he can switch off RSTP at this port. Thus no waiting times occur at this port in the case of a reconfiguration.
- ▶ Introduction of alternate ports:
As the port roles are already determined in normal operation, a bridge can immediately switch from the root port to the alternate port after the connection to the root bridge is lost.
- ▶ Communication with neighboring bridges (point-to-point connections):
The decentralized, direct communication between neighboring bridges enables immediate reaction to status changes in the spanning tree architecture.
- ▶ Address table:
With STP, the age of the entries in the address table determines the updating of the communication. RSTP immediately deletes the entries for those ports affected by a reconfiguration.
- ▶ Reaction to events:
Without having to adhere to any time specifications, RSTP immediately reacts to events such as connection interruptions, connection reinstatements, and the like.

Note: The drawback for this fast reconfiguration is the possibility that data packets may be duplicated or their sequence be altered during the reconfiguration phase. If this is unacceptable for your application, use the slower Spanning Tree Protocol or select one of the other, faster redundancy procedures described in this manual.

5.6.5 Configuring the Rapid Spanning Tree

- Set up the network to meet your demands.



WARNING

RSTP LOOP HAZARD

To avoid loops during the configuration phase, configure all the devices of the RSTP configuration individually. Before you connect the redundant lines, you must complete the configuration of all devices in the RSTP configuration.

Failure to follow these instructions can result in death, serious injury, or equipment damage.

- For devices with DIP switches, you switch these to “deactivated” (both to ON), so that the software configuration is not restricted.
- Select the `Redundancy:Rapid Spanning Tree:Global` dialog.
- Switch on RSTP on each device

Operation: On Off Protocol Version: RSTP

Protocol Configuration / Information

Bridge		Root	Topology	
Bridge ID	32768 / 00 80 63 97 50 00	20480 / 00 80 63 0f 1d b0	Bridge is Root	<input type="checkbox"/>
Priority	32768	20480	Root Port	1.4
Hello Time [s]	2	2	Root Path Cost	440000
Forward Delay [s]	15	30	Topology Change Count	3
Max. Age	20	6	Time Since Topology Change	0 day(s), 2:27:29
Tx Hold Count	10			
MRP Compatibility	<input type="checkbox"/>			
BPDU Guard	<input type="checkbox"/>			

Buttons: Set, Reload, Help

Figure 48: Operation on/off

- Define the desired Switch as the root bridge by assigning it the lowest priority in the bridge information among all the bridges in the network, in the “Protocol Configuration/Information” frame. Note that only multiples of 4,096 can be entered for this value (see table 16). In the “Root Information” frame, the dialog shows this device as the root.
A root switch has no root port and a root cost of 0.

- If necessary, change the default priority value of 32,768 in other bridges in the network in the same way to the value you want (multiples of 4,096).
For each of these bridges, check the display in the “Root Information” frame:
 - Root-ID: Displays the root bridge’s bridge identifier
 - Root Port: Displays the port leading to the root bridge
 - Root Cost: Displays the root cost to the root bridge
 in the “Protocol Configuration/Information” frame:
 - Priority: Displays the priority in the bridge identifier for this bridge
 - MAC Address: Displays the MAC address of this Switch
 - Topology Changes: Displays the number of changes since the start of RSTP
 - Time since last change: Displays the time that has elapsed since the last network reconfiguration
- If necessary, change the values for “Hello Time”, “Forward Delay” and “Max. Age” on the rootbridge. The root bridge then transfers this data to the other bridges. The dialog displays the data received from the root bridge in the left column. In the right column you enter the values which shall apply when this bridge becomes the root bridge. For the configuration, take note of [table 16](#).

Protocol Configuration / Information		Topology	
Bridge	Root	Bridge is Root	
Bridge ID	32768 / 00 80 63 97 50 00	20480 / 00 80 63 0f 1d b0	<input type="checkbox"/>
Priority	32768	20480	Root Port
Hello Time [s]	2	2	1.4
Forward Delay [s]	15	30	Root Path Cost
Max Age	20	6	440000
Tx Hold Count	10		Topology Change Count
MRP Compatibility	<input type="checkbox"/>		3
BPDU Guard	<input type="checkbox"/>		Time Since Topology Change
			0 day(s), 2:27:29

Figure 49: Assigning Hello Time, Forward Delay and Max. Age

The times entered in the RSTP dialog are in units of 1 s
Example: a Hello Time of 2 corresponds to 2 seconds.

- Now connect the redundant lines.

Parameter	Meaning	Possible Values	Default Setting
Priority	The priority and the MAC address go together to make up the bridge identification.	$0 < n * 4,096 (1000H) < 61,440 (F000H)$	32,768 (8000H)
Hello Time	Sets the Hello Time. The local <code>Hello Time</code> is the time in seconds between the sending of two configuration messages (Hello packets). If the local device has the root function, the other devices in the entire network take over this value. Otherwise the local device uses the value of the root bridge in the "Root" column on the right.	1 - 2	2
Forward Delay	Sets the Forward Delay parameter. In the previous STP protocol, the Forward Delay parameter was used to delay the status change between the statuses <code>disabled</code> , <code>discarding</code> , <code>learning</code> , and <code>forwarding</code> . Since the introduction of RSTP, this parameter has a subordinate role, because the RSTP bridges negotiate the status change without any specified delay. If the local device is the root, the other devices in the entire network take over this value. Otherwise the local device uses the value of the root bridge in the "Root" column on the right.	4 - 30 s See the note following this table.	15 s
Max Age	Sets the Max Age parameter. In the previous STP protocol, the Max Age parameter was used to specify the validity of STP BPDUs in seconds. For RSTP, Max Age signifies the maximum permissible branch length (number of devices to the root bridge). If the local device is the root, the other devices in the entire network take over this value. Otherwise the local device uses the value of the root bridge in the "Root" column on the right.	6 - 40 s See the note following this table.	20 s

Table 16: Global RSTP settings

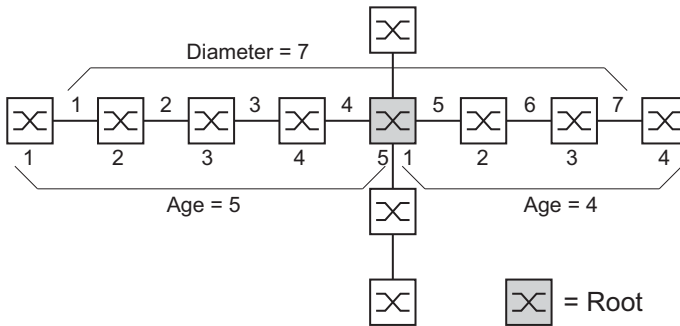

Figure 50: Definition of diameter and age

The network diameter is the number of connections between the two devices furthest away from the root bridge.

Note: The parameters

- Forward Delay and
- Max Age

have a relationship to each other:

Forward Delay \geq (Max Age/2) + 1

If you enter values that contradict this relationship, the device then replaces these values with a default value or with the last valid values.

- When necessary, change and verify the settings and displays that relate to each individual port (dialog: Rapid Spanning Tree:Port).

Module	Port	STP State Enable	Port State	Priority	Port Pathcost	Admin EdgePort	Oper EdgePort	Auto EdgePort	Oper PointToPoint	Designated Root (Priority/MAC/Adine)
1	1	<input checked="" type="checkbox"/>	disabled	128	0	false	false	true	false	80 00 00 80 63 74 67
1	2	<input checked="" type="checkbox"/>	disabled	128	0	false	false	true	false	80 00 00 80 63 74 67
1	3	<input checked="" type="checkbox"/>	disabled	128	0	false	false	true	false	80 00 00 80 63 74 67
1	4	<input checked="" type="checkbox"/>	disabled	128	0	false	false	true	false	80 00 00 80 63 74 67
1	5	<input checked="" type="checkbox"/>	disabled	128	0	false	false	true	false	80 00 00 80 63 74 67
1	6	<input checked="" type="checkbox"/>	disabled	128	0	false	false	true	false	80 00 00 80 63 74 67
1	7	<input checked="" type="checkbox"/>	disabled	128	0	false	false	true	false	80 00 00 80 63 74 67
1	8	<input checked="" type="checkbox"/>	disabled	128	0	false	false	true	false	80 00 00 80 63 74 67
1	9	<input checked="" type="checkbox"/>	manualPvid	128	0	false	false	true	true	80 00 00 80 63 74 67
1	10	<input checked="" type="checkbox"/>	disabled	128	0	false	false	true	false	80 00 00 80 63 74 67
1	11	<input checked="" type="checkbox"/>	disabled	128	0	false	false	true	false	80 00 00 80 63 74 67
1	12	<input checked="" type="checkbox"/>	disabled	128	0	false	false	true	false	80 00 00 80 63 74 67
1	13	<input checked="" type="checkbox"/>	disabled	128	0	false	false	true	false	80 00 00 80 63 74 67
1	14	<input checked="" type="checkbox"/>	disabled	128	0	false	false	true	false	80 00 00 80 63 74 67
1	15	<input checked="" type="checkbox"/>	disabled	128	0	false	false	true	false	80 00 00 80 63 74 67
1	16	<input checked="" type="checkbox"/>	disabled	128	0	false	false	true	false	80 00 00 80 63 74 67
1	17	<input checked="" type="checkbox"/>	disabled	128	0	false	false	true	false	80 00 00 80 63 74 67
1	18	<input checked="" type="checkbox"/>	disabled	128	0	false	false	true	false	80 00 00 80 63 74 67
1	19	<input checked="" type="checkbox"/>	disabled	128	0	false	false	true	false	80 00 00 80 63 74 67
1	20	<input checked="" type="checkbox"/>	disabled	128	0	false	false	true	false	80 00 00 80 63 74 67
1	21	<input checked="" type="checkbox"/>	disabled	128	0	false	false	true	false	80 00 00 80 63 74 67
1	22	<input checked="" type="checkbox"/>	disabled	128	0	false	false	true	false	80 00 00 80 63 74 67

Figure 51: Configuring RSTP per port

Note: Deactivate the Spanning Tree Protocol on the ports connected to a redundant ring, because Spanning Tree and Ring Redundancy work with different reaction times.

If you are using the device in a Multiple Spanning Tree (MSTP) environment, the device only participates in the Common Spanning Tree (CST) instance. This chapter of the manual also uses the term Global MST instance to describe this general case.

Parameter	Meaning	Possible Values	Default Setting
STP active	Here you can switch Spanning Tree on or off for this port. If Spanning Tree is activated globally and switched off at one port, this port does not send STP-BPDUs and drops any STP-BPDUs received.	On, Off	On
	<p>Note: If you want to use other layer 2 redundancy protocols such as HIPER-Ring or Ring/Network coupling in parallel with Spanning Tree, confirm that you switch off the ports participating in these protocols in this dialog for Spanning Tree. Otherwise the redundancy may not operate as intended or loops can result.</p>		
Port status (read only)	Displays the STP port status with regard to the global MSTI (IST).	discarding, learning, forwarding, disabled, manualForwarding, notParticipate	-
Port priority	Here you enter the port priority (the four highest bits of the port ID) with regard to the global MSTI (IST) as a decimal number of the highest byte of the port ID.	$16 \leq n \leq 240$	128
Port path costs	Enter the path costs with regard to the global MSTI (IST) to indicate preference for redundant paths. If the value is 0, the Switch automatically calculates the path costs for the global MSTI (IST) depending on the transmission rate.	0 - 200,000,000	0 (automatically)

Table 17: Port-related RSTP settings and displays

Parameter	Meaning	Possible Values	Default Setting
Admin Edge Port	<p>Activate this setting only if a terminal device is connected to the port. Then the port immediately transitions to the forwarding status after a link is set up, without first going through the STP statuses. If the port still receives an STP-BPDU, the device blocks the port and clarifies the port's STP port role. In the process, the port can switch to a different status, e.g. <i>forwarding</i>, <i>discarding</i>, <i>learning</i>.</p> <p>Deactivate the setting when the port is connected to a bridge. After a link is set up, the port then goes through the STP statuses first before taking on the <i>forwarding</i> status, if applicable.</p> <p>This setting applies to all MSTIs.</p>	<p><i>active</i> (box selected),</p> <p><i>inactive</i> (box empty)</p>	<i>inactive</i>
Oper Edge Port (read only)	<p>The device sets "Oper Edge Port" condition to <i>true</i> if no STP-BPDUs have been received, i.e., a terminal device is connected. It sets the state to <i>false</i> if STP-BPDUs have been received, i.e., a bridge is connected. This condition applies to all MSTIs.</p>	<i>true, false</i>	-
Auto Edge Port	<p>The device only considers the Auto Edge Port setting when the Admin Edge Port parameter is deactivated. If Auto Edge Port is active, after a link is set up the device sets the port to the forwarding status after $1.5 \cdot \text{Hello Time}$ (in the default setting 3 s).</p> <p>If Auto Edge Port is deactivated, the device waits for the <i>Max Age</i> instead (in the default setting 20 s).</p> <p>This setting applies to all MSTIs.</p>	<p><i>active</i> (box selected),</p> <p><i>inactive</i> (box empty)</p>	<i>active</i>

Table 17: Port-related RSTP settings and displays

Parameter	Meaning	Possible Values	Default Setting
Actual point-to-point (read only)	The device sets the “Actual point-to-point” condition to <code>true</code> if this port has a full duplex condition to an STP device. Otherwise it sets the condition to <code>false</code> (e.g. if a hub is connected). The point-to-point connection makes a direct connection between 2 RSTP devices. The direct, decentralized communication between the two bridges results in a short reconfiguration time. This condition applies to all MSTIs.	<code>true, false</code> The device determines this condition from the duplex mode: FDX: <code>true</code> HDX: <code>false</code>	
Received bridge ID (read only)	Displays the remote bridge ID from which this port last received an STP-BPDU. ^a	Bridge identification (format ppppp / mm mm mm mm mm mm)	-
Received path costs (read only)	Displays the path costs of the remote bridge from its root port to the CIST root bridge. ^a	0-200,000,000	-
Received port ID (read only)	Displays the port ID at the remote bridge from which this port last received an STP-BPDU. ^a	Port ID, format pn nn, with p: port priority / 16, nnn: port No., (both hexadecimal)	-

Table 17: Port-related RSTP settings and displays

- ^a These columns show you more detailed information:
For designated ports, the device displays the information for the STP-BPDU last received by the port. This helps with the diagnosis of possible STP problems in the network.
For the port roles alternative, back-up and root, in the stationary condition (static topology), this information is identical to the designated information.
If a port has no link, or if it has not received any STP-BDPUs yet, the device displays the values that the port would send as a designated port.

5.7 Combining RSTP and MRP

In the MRP compatibility mode, the device allows you to combine RSTP with MRP.

With the combination of RSTP and MRP, the fast switching times of MRP are maintained.

The RSTP diameter (see figure 50) depends on the “Max Age”. It applies to the devices outside the MRP-Ring.

Note: The combination of RSTP and MRP presumes that both the root bridge and the backup root bridge are located within the MRP-Ring.

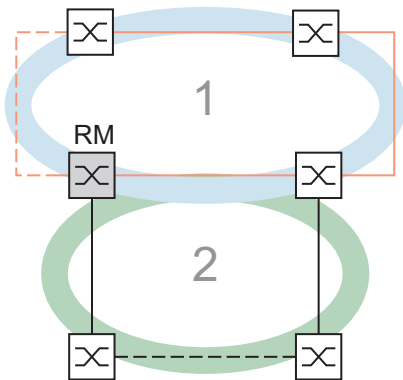

Figure 52: Combination of RSTP and MRP

1: MRP-Ring

2: RSTP-Ring

RM: Ring Manager

To combine RSTP with MRP, you perform the following steps in sequence:

- ▶ Configure MRP on each device in the MRP-Ring.
- ▶ Connect the redundant line in the MRP-Ring.

- ▶ Activate RSTP on the RSTP ports and on the MRP-Ring ports.
- ▶ Configure the RSTP root bridge and the RSTP backup root bridge in the MRP-Ring:
 - Set the priority.
 - If you exceed the RSTP diameter specified by the default value of Max Age = 20, modify “Max Age” and “Forward Delay” accordingly.
- ▶ Activate RSTP globally.
- ▶ Activate the MRP compatibility mode.
- ▶ After configuring all the participating devices, connect the redundant RSTP connection.

5.7.1 Application example for the combination of RSTP and MRP

The figure (see figure 53) shows an example for the combination of RSTP and MRP.

Parameter	S1	S2	S3	S4	S5	S6
MRP settings						
Ring redundancy: MRP version	MRP	MRP			MRP	MRP
Ring port 1	1.2	1.1			1.1	1.1
Ring port 2	1.1	1.2			1.2	1.2
Port from MRP-Ring to the RSTP net	1.3	1.3	-	-	-	-
Redundancy Manager mode	On	Off	-	-	Off	Off
MRP operation	On	On	Off	Off	On	On
RSTP settings						
For each RSTP port: STP State Enable	On	On	On	On	On	On
Protocol Configuration: Priority (S2<S1<S3 and S2<S1<S4)	4,096	0	32,768	32,768	32.768	32.768
RSTP:Global: Operation	On	On	On	On	On	On
RSTP:Global: MRP compatibility	On	On	-	-	On	On

Table 18: Values for the switch configuration in the MRP/RSTP example

Prerequisites for further configuration:

- ▶ You have configured the MRP settings for the devices in accordance with the above table.
- ▶ The MRP-Ring's redundant line is connected.

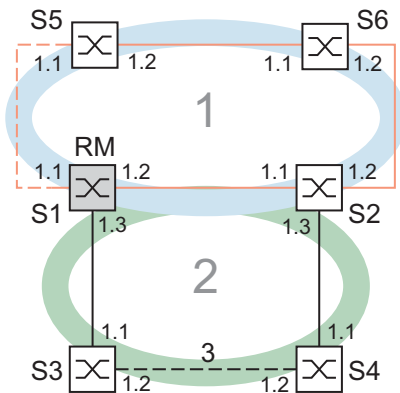

Figure 53: Application example for the combination of RSTP and MRP
 1: MRP-Ring, 2: RSTP-Ring, 3: Redundant RSTP connection
 RM: Ring Manager
 S2 is RSTP Root Bridge
 S1 is RSTP Backup Root Bridge

- Activate RSTP at the ports, using S1 as an example (see table 18).

```
enable
configure
interface 1/1

spanning-tree port mode
exit
interface 1/2

spanning-tree port mode
exit
interface 1/3

spanning-tree port mode
exit
```

```
Switch to the Privileged EXEC mode.
Switch to the Configuration mode.
Switch to the Interface Configuration mode of
interface 1/1.
Activate RSTP on the port.
Switch to the Configuration mode.
Switch to the interface configuration mode for
port 1.2.
Activate RSTP on the port.
Switch to the Configuration mode.
Switch to the interface configuration mode for
port 1.3.
Activate RSTP on the port.
Switch to the Configuration mode.
```

- Configure the global settings, using S1 as an example:
 - the RSTP priority
 - global operation
 - the MRP compatibility mode

<pre>spanning-tree mst priority 0 4096</pre>	Set the RSTP priority for the MST instance 0 to the value 4,096. the MST instance 0 is the default instance.
<pre>spanning-tree</pre>	Activate RSTP operation globally.
<pre>spanning-tree stp-mrp-mode</pre>	Activate MRP compatibility.

- Configure the other switches S2 though S6 with their respective values ([see table 18](#)).
- Connect the redundant RSTP connection.

5.8 Dual RSTP (TCSESM-E)

5.8.1 Introduction

Industrial applications require your networks to have high availability. This also involves maintaining deterministic, short interruption times for the communication when one of the network components becomes inoperable. A ring topology provides short switching times with a minimal use of resources, but it also brings the challenge of coupling these rings redundantly to a higher-level network.

If you want to use a standard protocol such as RSTP for both the ring redundancy and for coupling to a higher-level ring, Dual RSTP provides you with special options.

Dual RSTP combines:

- ▶ the benefits of the RSTP standard, such as the automatic setting up of a functioning redundancy topology without the explicit configuration of devices in the state on delivery
- ▶ with the required short, deterministic reconfiguration times should a network component become inoperable.

Dual RSTP allows you to couple multiple secondary rings to a primary ring (see [figure 54](#)).

Each secondary ring represents a separate RSTP instance that works independently of the RSTP instance of the primary ring and of the other secondary rings.

Only the bridges that couple the rings require the Dual RSTP function; the other bridges work with the standard RSTP.

If a network component becomes inoperable in a secondary ring, Dual RSTP achieves a deterministic, short reconfiguration time by means of:

- ▶ the physical ring topology,
- ▶ a defined number of ring participants and
- ▶ an optimized configuration of the RSTP bridge priorities.

When there is a defined number of bridges in the primary ring, Dual RSTP also achieves this short reconfiguration time in the primary ring. Overall, Dual RSTP also provides this reconfiguration time end-to-end between any network nodes in a network made up of one primary ring and multiple secondary rings.

You have the option of operating up to 16 TCSESM-E devices in a Sub-Ring. This includes the two devices of the primary ring that connect the secondary ring.

Thus, Dual RSTP can achieve a maximum reconfiguration time of 50 ms should a network component become inoperable in the secondary ring. You also have the option of operating up to 16 TCSESM-E devices in a primary ring. Thus, Dual RSTP can also achieve a maximum reconfiguration time of 50 ms in the primary ring.

You can connect up to 8 secondary rings to a primary ring. Thus, you can connect up to 128 bridges ($8 \times 14 + 16$). Within this network, you can achieve a maximum end-to-end reconfiguration time of 50 ms with device redundancy.

When the requirements for the reconfiguration time in the primary ring are lower, you have the following options:

- ▶ To increase the number of bridges in the primary ring and thus
- ▶ connect additional secondary rings to the primary ring

You can also use devices other than TCSESM-E within the rings, provided that the devices update the RSTP topology changes fast enough should a network component become inoperable.

5.8.2 Coupling the Dual RSTP instances

You have the option of connecting a secondary ring to the primary ring via one bridge or two (see figure 54). When using 1 bridge, you achieve connection redundancy, and when using 2 bridges you also have device redundancy.

■ Connecting the RSTP-Rings with 2 Dual RSTP bridges

The bridges that connect the secondary ring to the primary ring are the only bridges that manage 2 RSTP instances and thus actually achieve Dual RSTP. Therefore, they are referred to as Dual RSTP bridges here. They are partner bridges in the context of Dual RSTP.

If you are using 2 Dual RSTP bridges, connect these directly to each other for each instance, i.e. with 2 connections. These ports are known as “inner ports”, because they connect the two partner bridges directly (see [figure 54](#)). Every partner bridge has an inner port for the primary ring and one for the secondary ring.

The ports that are connected to the other ring bridges in the primary and secondary rings are known as “outer ports”, because in the graphic representation of the topology they are located opposite the inner ports.

When 2 bridges are used, one of the bridges actively assumes the task of connecting the secondary ring to the primary ring. This bridge is known as the Dual RSTP master, while its partner bridge is known as the Dual RSTP slave.

If the Dual RSTP master becomes inoperable, the Dual RSTP slave takes over the task of connecting the rings.

If the existing Dual RSTP master becomes operational again, it takes over:

- ▶ the `master` role again if the `master` and `slave` roles have a fixed configuration or
- ▶ the new `slave` role if both bridges are configured to the `auto` role.

Configuring both bridges to the `auto` role has the advantage that when the previous master becomes operational again, it is not necessary to reconfigure the topology again.

■ Connecting the RSTP-Rings with a Dual RSTP bridge

If you are using a Dual RSTP bridge to connect a secondary ring to a primary ring, configure this for the `single` coupling role.

Note: Only use the `single` coupling role when connecting rings with a Dual RSTP bridge.

For a Dual-RSTP bridge with the `single` role, the inner and outer ports have the same function. You can interchange the inner and outer ports of a specific instance.

When using one bridge to connect the rings, you can connect up to 16 secondary rings to a primary ring. This includes the Dual-RSTP bridge that connects the rings.

Thus, you can connect up to 256 bridges ($16 \times 15 + 16$). Within this network, you can achieve a maximum end-to-end reconfiguration time of 50 ms within a network with connection redundancy.

When the requirements for the reconfiguration time in the primary ring are lower, you have the option of increasing the number of bridges in the primary ring. You can thus also connect more secondary rings to the primary ring.

■ Properties of the primary and secondary instance's ports

For ports of a primary or a secondary instance, heed the following notes:

Note: Only those ports of a Dual RSTP Bridge that are configured as the secondary ring's outer or inner ring ports belong to the secondary RSTP instance.

All other ports belong to the Dual RSTP Bridge's primary instance.

Note: You have the possibility to connect the following types of network nodes to a port that implicitly belongs to a Dual RSTP bridge's primary instance:

- ▶ end devices, or
- ▶ networks that do not run spanning tree.

To such topologies, neither device redundancy nor link redundancy applies.

Note: You have the possibility to create a meshed network within the primary or the secondary ring by establishing additional links between ports of the same instance. To such topologies, a defined maximum end-to-end reconfiguration time of 50 ms does not apply.

5.8.3 Topologies and configuration

■ Topology options for Dual RSTP

The following example shows the basic structure of a primary ring to which 3 secondary rings are connected.

Secondary rings 1 and 2 are connected to the primary ring using 2 Dual RSTP bridges each, and secondary ring 3 with 1 Dual RSTP bridge.

The path costs for all connections within a rings are assumed to be the same.

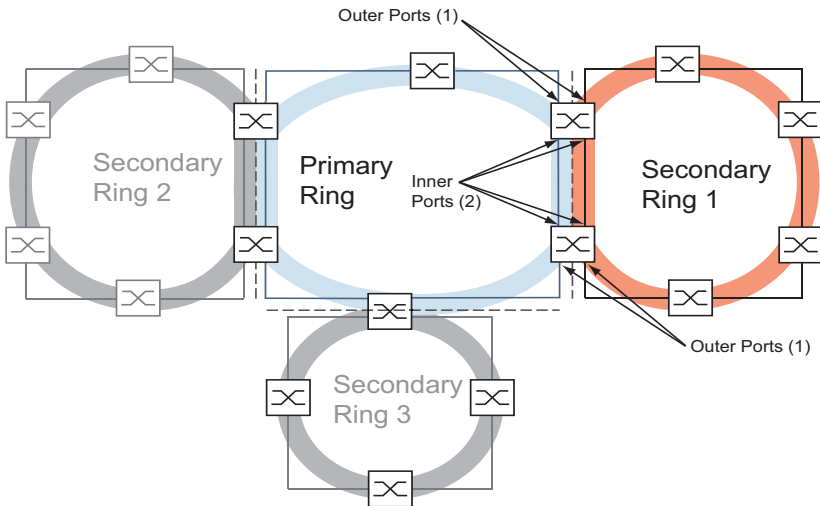

Figure 54: Primary ring with 3 secondary rings connected via Dual RSTP,
 1: outer ports
 2: inner ports

■ Configuration of the primary ring

Note: The following chapters describe the configuration in principle, and therefore omit details of the work steps.

When performing an actual configuration, take steps to avoid generating loops.

To define the root bridge and the backup root bridge in the primary ring, configure their global RSTP bridge priority. You will achieve an optimally short reconfiguration time in the primary ring when the root bridge and the backup root bridge are opposite each other in the primary ring. This is the case when the backup root bridge has 2 paths to the root bridge whose branch lengths differ by a maximum of 1.

Configure the other bridges in the primary ring that are located between the root bridge and the backup root bridge in such a way that the bridge priorities decrease (i.e. increase numerically) as their distance from the root bridge increases.

The figure shows an example with the RSTP details for the primary ring. The topology is reduced to the primary ring and one secondary ring. The configuration computer is connected to the primary ring in order to avoid interruptions to the communication to the bridges in the secondary ring during the course of the configuration.

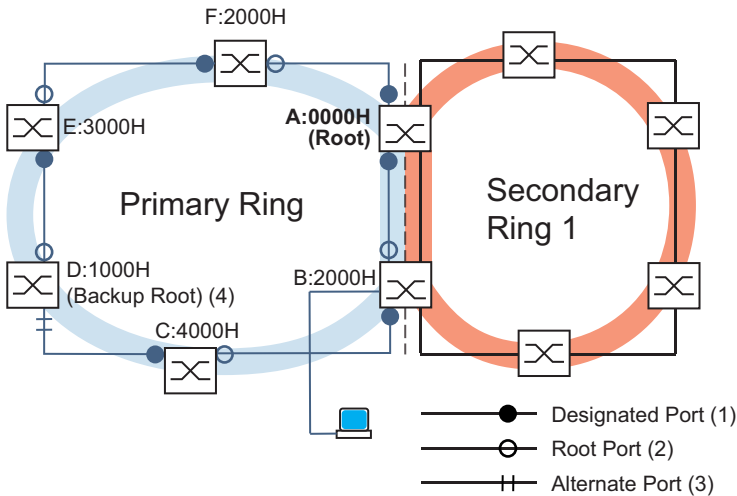

Figure 55: Primary ring with 1 connected secondary ring,
with details for the primary ring,
A..F: bridge identifiers
0000H..4000H: bridge priorities in the primary ring
1: designated port
2: root port
3: alternate port
4: backup root bridge for primary ring

Note: You also have the option of operating the primary ring with a ring redundancy protocol instead of with RSTP (see on page 17 “Ring Redundancy”).

Note: The root bridge roles in the primary ring and in the secondary ring are independent of each other.

A bridge can be:

- ▶ RSTP root for both rings,
- ▶ RSTP root for one ring or
- ▶ RSTP root for no ring.

Note: Operate the secondary ring only with RSTP.

■ Configuring the coupling of the rings

For the Dual RSTP bridges, define the inner and outer ports for both the primary and secondary rings.

Ports	Dual RSTP master (B)	Dual RSTP slave (A)
Primary ring		
Inner port	1.1	1.1
Outer port	1.2	1.2
Secondary ring		
Inner port	1.3	1.3
Outer port	1.4	1.4

Table 19: Ring ports for the Dual RSTP bridges

Afterwards, configure the coupling role for each Dual RSTP bridge.

The figure shows an example.

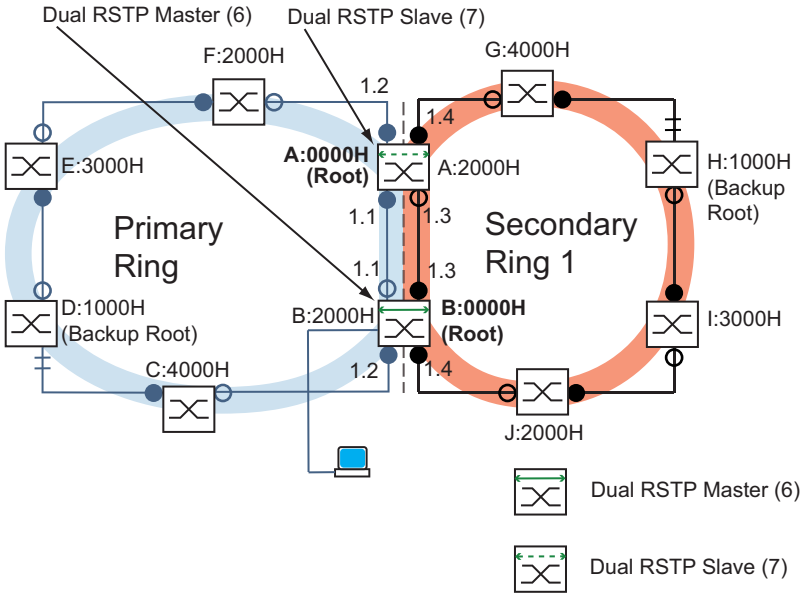

Figure 57: Primary ring with 1 connected secondary ring, with port numbers and Dual RSTP coupling roles, 6: Dual RSTP master 7: Dual RSTP slave

Note: The root bridge roles and the coupling roles are independent of each other.

A bridge can be Dual RSTP master and simultaneously:

- ▶ RSTP root for both rings,
- ▶ RSTP root for one ring or
- ▶ RSTP root for no ring.

The same applies to the Dual RSTP slave.

Afterwards, activate Dual RSTP.

5.8.4 Application example for Dual RSTP

In a production hall, there are multiple production cells. The devices within a production cell are already connected in a line network structure. This network is connected to the higher-level network in the production hall. The production hall's network is redundantly interconnected and works with RSTP. All devices are of the TCSESM-E type.

You want to:

- ▶ equip the existing line network in the production cells with a fast device redundancy,
- ▶ connect the production cells redundantly to the network of the production hall and
- ▶ reconfigure the network of the production hall so that it provides deterministic, short reconfiguration times.

Existing network topology, reduced to 1 production cell:

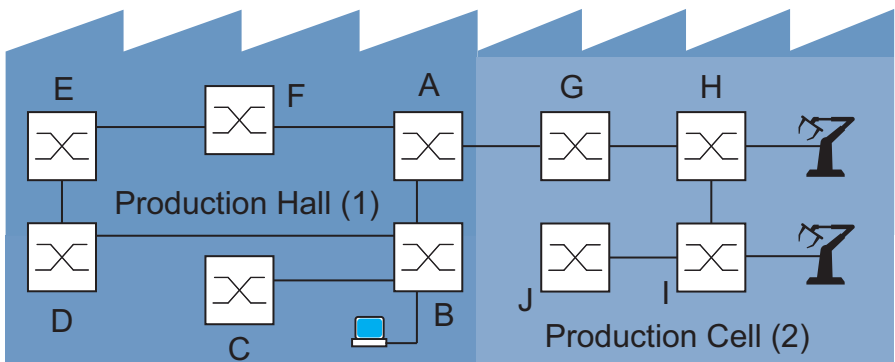

Figure 58: Example of a production cell in a production hall, topology before using Dual RSTP
 1: production hall
 2: production cell

Desired Dual RSTP network topology:

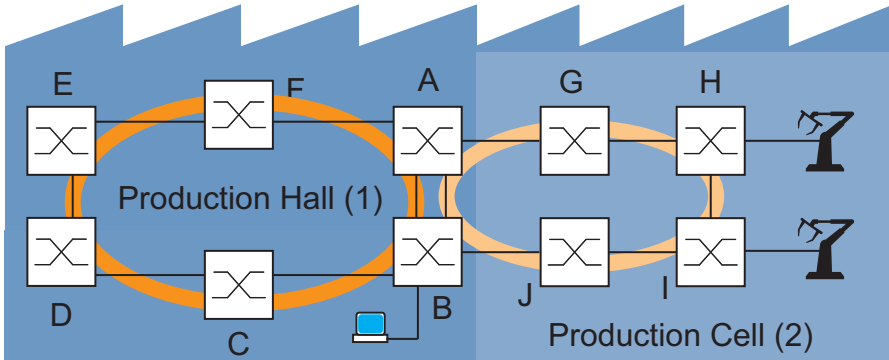

Figure 59: Example of a production cell in a production hall, topology when using Dual RSTP
1: production hall
2: production cell

Schematic representation of desired Dual RSTP network topology:

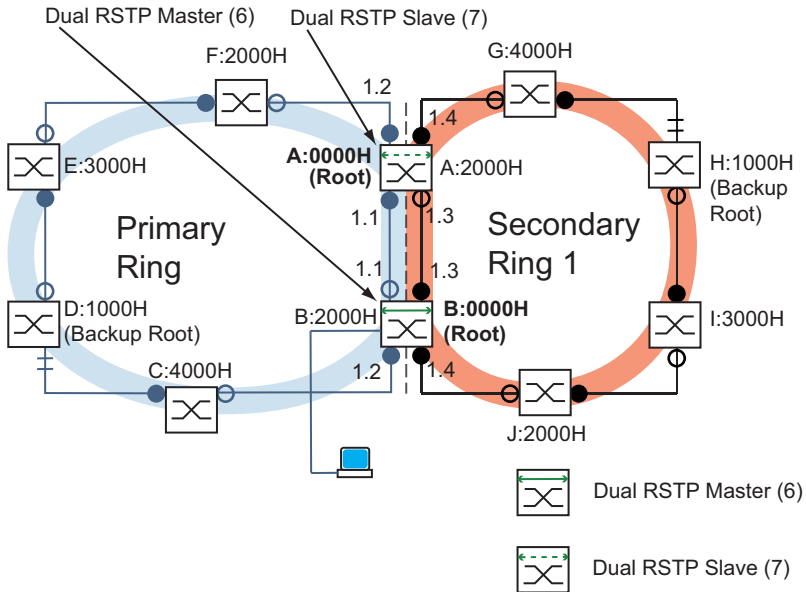

Figure 60: Schematic representation of Dual RSTP network topology,
6: Dual RSTP master
7: Dual RSTP slave

Parameter	A	B	C	D	E	F	G	H	I	J
RSTP settings										
Bridge priority (hex.) ^a	0000	2000	4000	1000	3000	2000	4000	1000	3000	2000
Dual RSTP settings										
Bridge priority (hex.) ^a	2000	0000	-	-	-	-	-	-	-	-
Primary ring, inner port	1.1	1.1	-	-	-	-	-	-	-	-
Primary ring, outer port	1.2	1.2	-	-	-	-	-	-	-	-
Secondary ring, inner port	1.3	1.3	-	-	-	-	-	-	-	-
Secondary ring, outer port	1.4	1.4	-	-	-	-	-	-	-	-
Coupling role	Slave	Master	-	-	-	-	-	-	-	-

Table 20: Values for the configuration of the Switches of the Dual RSTP example

a. For the bridge priorities in hexadecimal and decimal notation, see table 21.

The [table 20](#) shows that a relatively small number of settings are sufficient to configure the new topology. You only have to enter Dual RSTP settings on devices A and B.

Bridge priority								
Hexadecimal	0000	1000	2000	3000	4000	5000	6000	7000
Decimal	0	4096	8192	12288	16384	20480	24576	28672
<hr/>								
Hexadecimal	8000	9000	A000	B000	C000	D000	E000	F000
Decimal	32768	36864	40960	45056	49152	53248	57344	61440

Table 21: Possible bridge priorities in hexadecimal and decimal notation

Prerequisites for further configuration:

- ▶ The connection for the existing interconnection -in the old topology- of the secondary ring between bridges B and D is inactive. You can achieve this, for example, by manually deactivating the corresponding ports on bridges B and D, or by breaking the link.
- ▶ The connections between bridges C and D and between bridges J and B are inactive. You can achieve this, for example, by manually deactivating the corresponding ports on the bridges before plugging in the links,
- ▶ the connection for the secondary ring between bridges A and B is inactive,
- ▶ RSTP is active on all the devices, and the parameters are in the state on delivery,
- ▶ your configuration computer is connected to the primary ring,
- ▶ you have opened the Web-based interface or the Command Line Interface for devices A and B and
- ▶ you have access to the user interfaces of devices C - J.

WARNING

DUAL RSTP LOOP HAZARD

- ▶ Configure all the devices of the Dual RSTP configuration individually. Before you connect the redundant lines, you must complete the configuration of all the devices of the Dual RSTP configuration.
- ▶ Configure the timeout in the Dual RSTP coupling configuration longer than the longest assumable interruption time for the faster instance of the redundancy protocol.
- ▶ In a topology with 2 coupling bridges, configure the coupling roles of the two devices only as Master, Slave or Auto.
- ▶ Couple the primary and the secondary instance only by means of 1 Dual RSTP Bridge (for a topology with 1 Dual RSTP Bridge) or by means of 2 Dual RSTP Bridges (for a topology with 2 Dual RSTP Bridges). Keep all ports of the primary instance separated from all ports of all secondary instances.
- ▶ Only activate the “Admin Edge Port” setting at a port when a terminal device is connected to the port.

Failure to follow these instructions can result in death, serious injury, or equipment damage.

■ Configuring the global RSTP parameters of the Dual RSTP bridges

For this you require the RSTP bridge priorities for bridges A and B from the specifications for the task in [table 20](#), which are summarized in the following [table 22](#).

RSTP parameter	A	B
Bridge priority (hex.)	0000	2000
Bridge priority (dec.)	0	8192

Table 22: RSTP bridge priorities for bridges A and B

Note: The following instructions describe the configuration of the Dual RSTP bridges (A and B) in detail; those of the other bridges (C - J) merely in abbreviated form.

- In the Web-based interface for device **A**, choose the Redundancy:Spanning Tree:Global dialog.
- For “Priority” select the value 0.
- Click on “Write”.

- In the Web-based interface for device **B**, choose the Redundancy:Spanning Tree:Global dialog.
- For “Priority” select the value 8192.
- Click on “Write”.

Select the Command Line Interface for device **A**.

```
enable
```

Switch to the Privileged EXEC mode.

```
configure
```

Switch to the Configuration mode.

```
spanning-tree mst priority
```

Sets the RSTP priority for MST instance 0 to the value 0. The MST instance 0 is the global MST instance, or the default instance.

```
0 0
```

Select the Command Line Interface for device **B**.

```
enable
```

Switch to the Privileged EXEC mode.

```
configure
spanning-tree mst priority
0 8192
```

Switch to the Configuration mode.
Sets the RSTP priority for the global MST instance to the value 8192.

■ Configuring the global RSTP parameters of the other bridges

Now configure the other bridges.

For this you require the RSTP bridge priorities from the task specifications, which are summarized in the following [table 23](#).

RSTP parameter	C	D	E	F	G	H	I	J
Bridge priority (hex.)	4000	1000	3000	2000	4000	1000	3000	2000
Bridge priority (dec.)	16384	4096	12288	8192	16384	4096	12288	8192

Table 23: RSTP bridge priorities for bridges C - J

- Set the RSTP bridge priority of device **C** to 16384 (4000H) and activate the setting.
- Set the RSTP bridge priority of device **D** to 4096 (1000H) and activate the setting.
- Set the RSTP bridge priority of device **E** to 12288 (3000H) and activate the setting.
- Set the RSTP bridge priority of device **F** to 8192 (2000H) and activate the setting.
- Set the RSTP bridge priority of device **G** to 16384 (4000H) and activate the setting.
- Set the RSTP bridge priority of device **H** to 4096 (1000H) and activate the setting.
- Set the RSTP bridge priority of device **I** to 12288 (3000H) and activate the setting.
- Set the RSTP bridge priority of device **J** to 8192 (2000H) and activate the setting.

■ Configuring the Dual RSTP parameters of the Dual RSTP bridges

For this you require the specific Dual RSTP parameters for bridges A and B from the task specifications.

These are the Dual RSTP bridge priorities, the ring ports and the coupling roles, which are summarized in the following [table 24](#).

Dual RSTP parameter	A	B
Dual RSTP bridge priority (hex.)	2000	0000
Dual RSTP bridge priority (dec.)	8192	0
Primary ring, inner port	1.1	1.1
Primary ring, outer port	1.2	1.2
Secondary ring, inner port	1.3	1.3
Secondary ring, outer port	1.4	1.4
Coupling role	Slave	Master

Table 24: Dual RSTP parameters for bridges A and B

- In the Web-based interface for device **A**, choose the Redundancy:Spanning Tree:Dual RSTP dialog.
- For “Priority” select the value 8192.
- In the “Dual RSTP Primary Ring” frame, select the value 1.1 for “Inner Port”.
- In the “Dual RSTP Primary Ring” frame, select the value 1.2 for “Outer Port”.
- In the “Dual RSTP Secondary Ring” frame, select the value 1.3 for “Inner Port”.
- In the “Dual RSTP Secondary Ring” frame, select the value 1.4 for “Outer Port”.
- In the “Dual RSTP Coupler Configuration” frame, select the value slave for “Role”.
- In the “Operation” frame, click “On”. This switches the Dual RSTP function on.
- Click on “Write”.

- In the Web-based interface for device **B**, choose the Redundancy:Spanning Tree:Dual RSTP dialog.
- For “Priority” select the value 0.

- In the “Dual RSTP Primary Ring” frame, select the value 1.1 for “Inner Port”.
- In the “Dual RSTP Primary Ring” frame, select the value 1.2 for “Outer Port”.
- In the “Dual RSTP Secondary Ring” frame, select the value 1.3 for “Inner Port”.
- In the “Dual RSTP Secondary Ring” frame, select the value 1.4 for “Outer Port”.
- In the “Dual RSTP Coupler Configuration” frame, select the value `master` for “Role”.
- In the “Operation” frame, click “On”. This switches the Dual RSTP function on.
- Click on “Write”.

Select the Command Line Interface for device **A**.

<code>spanning-tree priority 0 8192 drstp</code>	Sets the RSTP priority for the Dual RSTP instance to the value 8192.
<code>spanning-tree drstp port primary inner 1/1</code>	Selects port 1.1 as the inner port for the Dual RSTP primary ring.
<code>spanning-tree drstp port primary outer 1/2</code>	Selects port 1.2 as the outer port for the Dual RSTP primary ring.
<code>spanning-tree drstp port secondary inner 1/3</code>	Selects port 1.3 as the inner port for the Dual RSTP secondary ring.
<code>spanning-tree drstp port secondary outer 1/4</code>	Selects port 1.4 as the outer port for the Dual RSTP secondary ring.
<code>spanning-tree drstp role slave</code>	Configures this device as the Dual RSTP slave.
<code>spanning-tree drstp</code>	Activates Dual RSTP on this device.
<code>exit</code>	Switch to the privileged EXEC mode.

Select the Command Line Interface for device **B**.

<code>spanning-tree priority 0 0 drstp</code>	Sets the RSTP priority for the Dual RSTP instance to the value 0.
<code>spanning-tree drstp port primary inner 1/1</code>	Selects port 1.1 as the inner port for the Dual RSTP primary ring.
<code>spanning-tree drstp port primary outer 1/2</code>	Selects port 1.2 as the outer port for the Dual RSTP primary ring.
<code>spanning-tree drstp port secondary inner 1/3</code>	Selects port 1.3 as the inner port for the Dual RSTP secondary ring.
<code>spanning-tree drstp port secondary outer 1/4</code>	Selects port 1.4 as the outer port for the Dual RSTP secondary ring.
<code>spanning-tree drstp role master</code>	Configures this device as the Dual RSTP master.

```
spanning-tree drstp
exit
```

Activates Dual RSTP on this device.
Switch to the privileged EXEC mode.

■ Checking the configuration

- Activate the new redundant connections:
 - ▶ the connection of the inner ports for the secondary ring between device A, port 1.4 and device B, port 1.3
 - ▶ the ring closure for the secondary ring between devices G and H and
 - ▶ the ring closure for the primary ring between devices C and D.

- Check the settings. Compare:
 - ▶ the actual bridge roles in the primary ring with the desired bridge roles:
 - bridge A should be the root bridge,
Display in the Web-based interface: Redundancy:Spanning Tree:Global dialog, “Topology” column, display for “Bridge is root”,
Display in CLI: `show spanning-tree brief`
 - ▶ the 4 ports that you configured as the inner and outer ports in the primary and secondary rings with the specifications in [table 20](#),
Web-based interface: Redundancy:Spanning Tree: Dual RSTP dialog, “Dual RSTP Primary Ring” and “Dual RSTP Secondary Ring” frames,
CLI: `show spanning-tree drstp`
 - ▶ the actual bridge roles in the secondary ring with the desired bridge roles:
 - bridge B should be the root bridge,
Web-based Interface: Redundancy:Spanning Tree: Dual RSTP dialog, “Topology” column, display for “Bridge is root”,
CLI: `show spanning-tree drstp`

- ▶ the actual port roles of the bridges in the primary ring with the desired port roles:
 - bridge D should set its port that leads to bridge C to the `alternate` role,
Web-based interface: Redundancy:Spanning Tree:Port dialog, “Port role” table column,
CLI: `show spanning-tree interface 1/<port>`
 - the other ports of the bridges that lead in the direction of root bridge A should be set to the `root` role,
 - the other ports of the bridges that lead to backup root bridge D should be set to the `designated` role,
- ▶ the actual port roles of the bridges in the secondary ring with the desired port roles:
 - bridge H should set its port that leads to bridge G to the `alternate` role,
 - the other ports of the bridges that lead in the direction of root bridge B should be set to the `root` role,
 - the other ports of the bridges that lead to backup root bridge H should be set to the `designated` role,

■ Completing the configuration

Save the settings in the non-volatile memory.

- In the Web-based interface for device **A**, choose the `Basic Settings:Load/Save` dialog.
- Select the `Basic Settings: Load/Save` dialog.
- In the “Save” frame, click “to Device”.
Click on “Save”. The device saves the current configuration data in the local non-volatile memory and, if an EAM is connected, also in the EAM.
- In the Web-based interface for device **B**, choose the `Basic Settings:Load/Save` dialog.
- Select the `Basic Settings: Load/Save` dialog.
- In the “Save” frame, click “to Device”.
Click on “Save”. The device saves the current configuration data in the local non-volatile memory and, if an EAM is connected, also in the EAM.

Select the Command Line Interface for device **A**.

```
copy system:running-config  
nvram:startup-config
```

Save the current configuration to the non-volatile memory.

Select the Command Line Interface for device **B**.

```
copy system:running-config  
nvram:startup-config
```

Save the current configuration to the non-volatile memory.

Also permanently save the settings for devices C - J.

A Index

A

Advanced Mode	25
Age	105
Alternate port	97, 97
Application example of Dual RSTP	125
Automatic role (Dual RSTP)	117

B

Backup port	97
Backup root bridge, primary ring (Dual RSTP)	120
Backup root bridge, secondary ring (Dual RSTP)	122
BPDU	88
Bridge Identifier	84, 84
Bridge priorities, primary ring (Dual RSTP)	120
Bridge priorities, secondary ring (Dual RSTP)	122
Bridge Protocol Data Unit	88

C

Configuration error	24, 29, 35
Costs	85
Coupling (Dual RSTP)	116

D

Designated bridge	96
Designated port	96, 96
Diameter	105
Disabled port	97
DRSTP	115
Dual RSTP	115
Dual RSTP application example	125
Dual RSTP bridge	117
Dual RSTP roles	124
Dual RSTP topology	119
Dual RSTP, automatic role	117
Dual RSTP, master role	117
Dual RSTP, single role	117
Dual RSTP, slave role	117

E

Edge port	97, 97, 97
Example of Dual RSTP	125

F

Fast HIPER-Ring (port VLAN ID)	13
Forward Delay	104

H

Hello Time	104
HIPER-Ring	8, 13

I

Inner port (Dual RSTP)	117, 119
------------------------	----------

L

Loops	68, 70, 76, 78
-------	----------------

M

Max Age	104
MRP	8

N

Network load	81, 83
--------------	--------

O

Outer port (Dual RSTP)	117, 119
------------------------	----------

P

Partner bridges (Dual RSTP)	117
Path Cost	88
Port Identifier	84
Port number	87
Port priority (Spanning Tree)	87
Port state	98
Primary ring (Dual RSTP)	115, 119

R

Rapid Spanning Tree	13
Reconfiguration	83
Redundancy	8
Redundancy existing	24, 29, 35
Redundancy functions	13
Redundancy Manager	18
Redundant	17
Redundant connections	81
Redundant coupling	13, 13, 16
Ring	117
Ring coupling (Dual RSTP)	116
Ring Manager	18
Ring structure	18
Ring/Network Coupling	8
Ring/Network coupling	13
RM function	17
Root Bridge	88
Root bridge roles (Dual RSTP)	123, 124
Root bridge, primary ring (Dual RSTP)	120

Root bridge, secondary ring (Dual RSTP)	122
Root Path Cost	84
Root port	96, 96
RST BPDU	97, 99
RSTP	13
RSTP instance (Dual RSTP)	115

S

Secondary ring (Dual RSTP)	115, 122
Single role (Dual RSTP)	117
Sub-Ring	13
Symbol	10

T

Topology, Dual RSTP	119
---------------------	-----

V

VLAN (HIPER-Ring settings)	23
----------------------------	----

