

THIS COPY IS PROVIDED ON A RESTRICTED BASIS AND IS NOT TO BE USED IN ANY WAY DETRIMENTAL TO THE INTERESTS OF PANDUIT CORP.

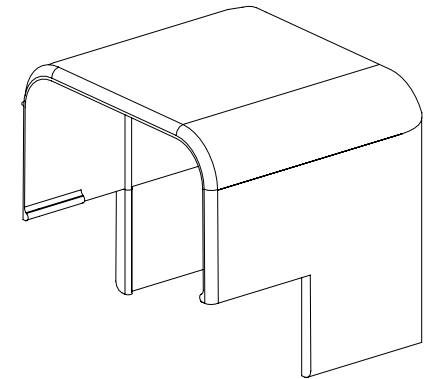
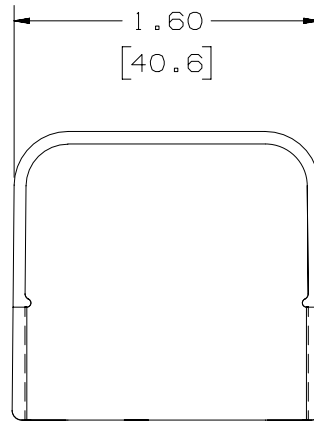
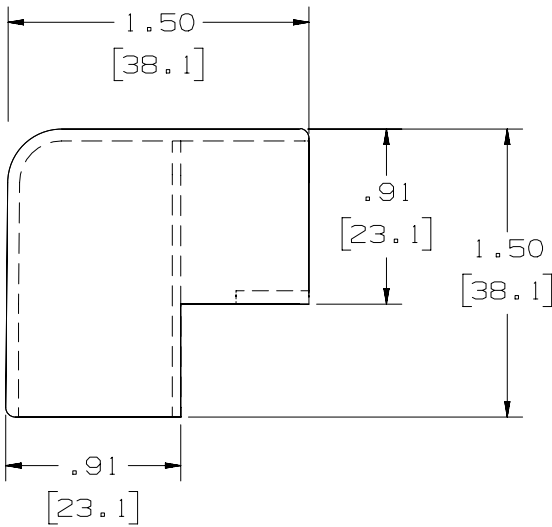
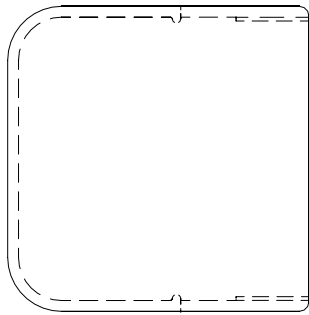

PANDUIT P/N	WEIGHT
OCF10	1.36 lb/ 100PCS. (617g/ 100PCS.)

NOTES:

- SEE WWW.PANDUIT.COM FOR ADDITIONAL PART SUFFIXES TO INDICATE COLOR AND OR PACKAGE QUANTITY.
- DIMENSIONS IN PARENTHESIS ARE IN METRIC.

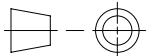
PART NUMBER		SEE TABLE	
TITLE		OUTSIDE CORNER FITTING	
		CUSTOMER DRAWING	
ITEM REVISION NAME		D34116BE/06	
DATASET FILE NAME		D34116BE_DC_OCF10_06A	
		THIRD ANGLE PROJECTION	
MATERIAL		ABS/PC	
		DRAWING NUMBER	
		SS-17777	
DRAWN BY	DATE	CHK	SCALE
SARGIS	11-04-82	JVL	FULL
REV		SHEET 1 OF 1	
DATE		A	

REV	DATE	BY	CHK	APR	DESCRIPTION	ECN
06A	04-18-23	BJN	BSN	TAM	MADE UNITS LOWER CASE; NOTE 1: MADE WWW.PANDUIT.COM; ABS/PC WAS POLYSTYRENE	M09000TA