



OPTICOM™ FIBER OPTIC RACK MOUNT ENCLOSURE

Part Numbers: FRME1

CM274 INSTALLATION INSTRUCTIONS

© Panduit Corp. 2002

Printed in U.S.A.

FRME Enclosure

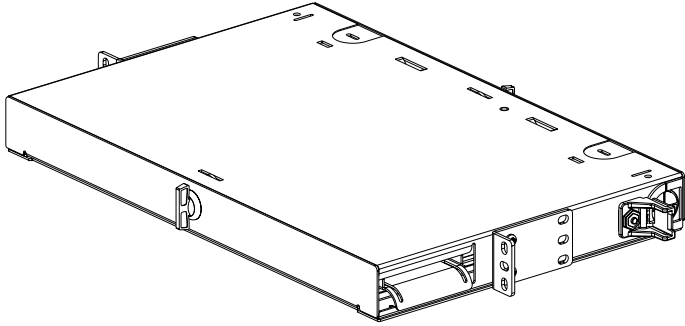

FRME1

- 1 FRME Enclosure
- 1 Port I.D. Label
- 2 EIA Enclosure Brackets
- 1 FRME Kit

Contents FRME Kit:

- (1) Grounding Lug
- (2) Cable Tie
- (1) #10-32x3/8" Screw
- (1) #10-32x1/4" Screw
- (4) #12-24x1/2" Screw
- (1) Fiber Caution Label
- (1) Fiber Laser Beam Warning Label
- (2) Grommet
- (2) #10-32 Hex Nut
- (1) Strain Relief

Assembly Instructions:

1. Determine the cable entry location on the enclosure. Remove the knockout by inserting a screwdriver into the slot located in the center of the knockout and apply a twisting downward motion then lift out. Insert grommet following proper cutting diagram. Grounding Lug attaches to a stud at the rear, inside the enclosure on the top or bottom with a #10-32 nut. Apply Laser Warning Label and Caution Label in a clearly visible location. Apply Port I.D. Label (s) on the inside of the tray.

GROMMET CUTTING DIAGRAM



Cut the small circle for 1" diameter innerduct

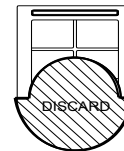

Cut the large circle for 1-1/2" diameter innerduct

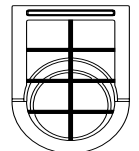

Cut the straight lines when not using any innerduct

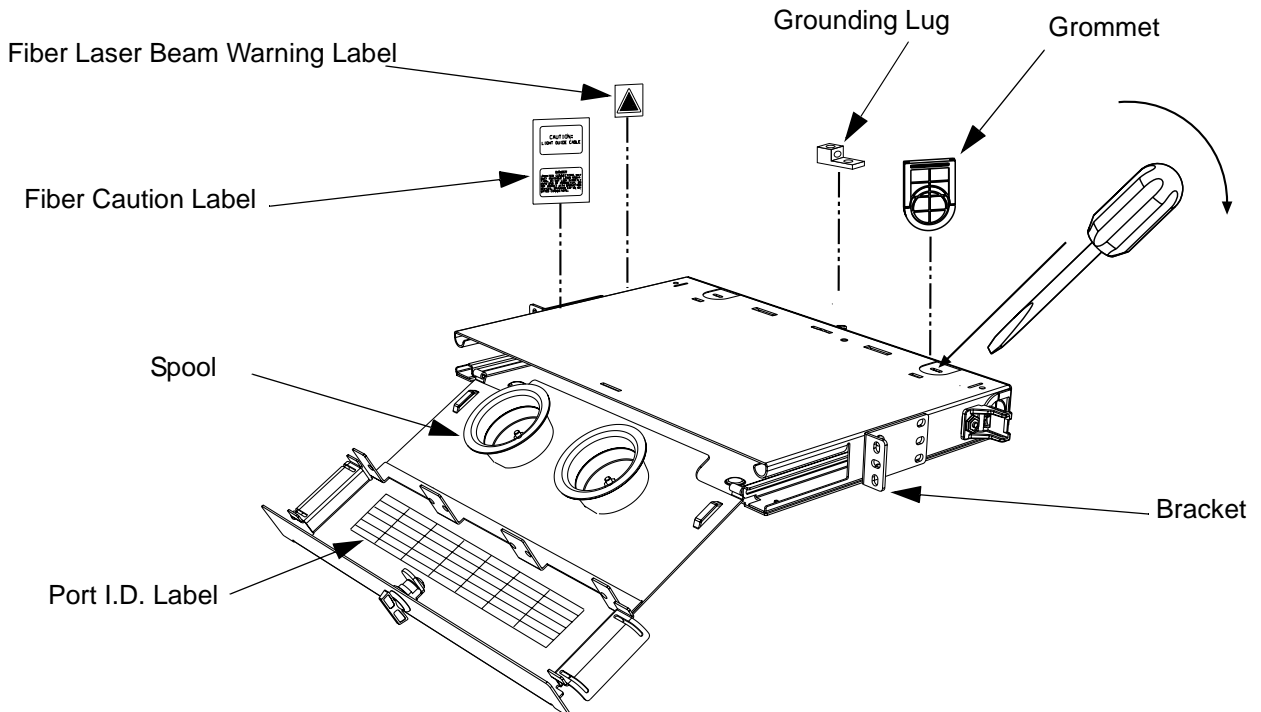

FOR TECHNICAL SUPPORT CALL: 866-405-6654

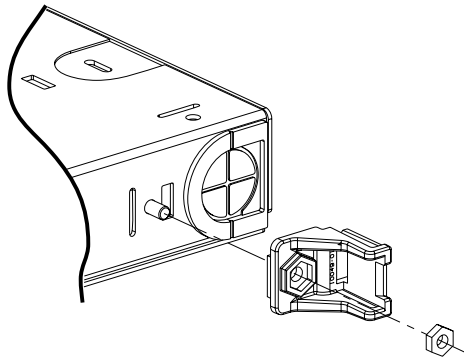

Attach Strain Relief Clip with the #10-32 screw and nut provided.

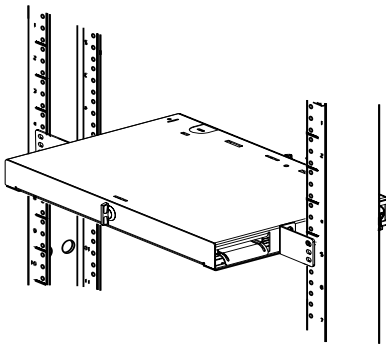

Bracket orientation for 23 inch rack

Attach the short leg of the bracket to the enclosure.

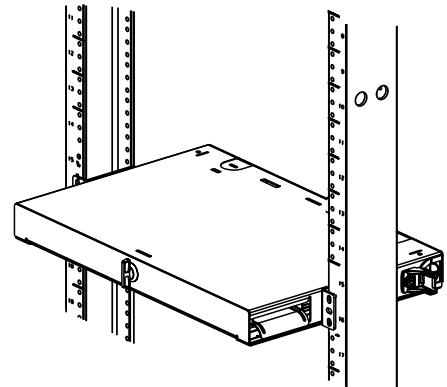

Bracket orientation for projection mount on a 19 inch rack

Locate rack bracket on the mid enclosure mounting holes for projection mounting

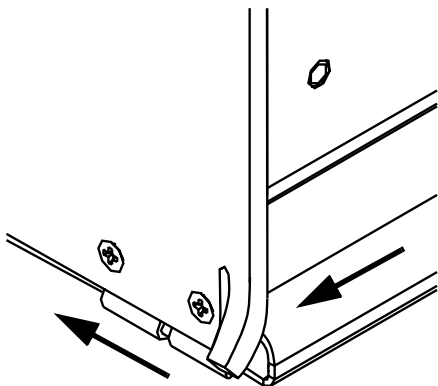

To remove the rear door, deflect the release tab and slide the door off its hinge

WORLDWIDE SUBSIDIARIES AND SALES OFFICES



412 Rockwell Court
Burr Ridge, Illinois 60521

Technical Support: 866-405-6654
Toll Free Fax: 866-449-1697

E-mail: ncginfo@panduit.com
Web site: www.panduit.com/ncg