

TOP VIEW

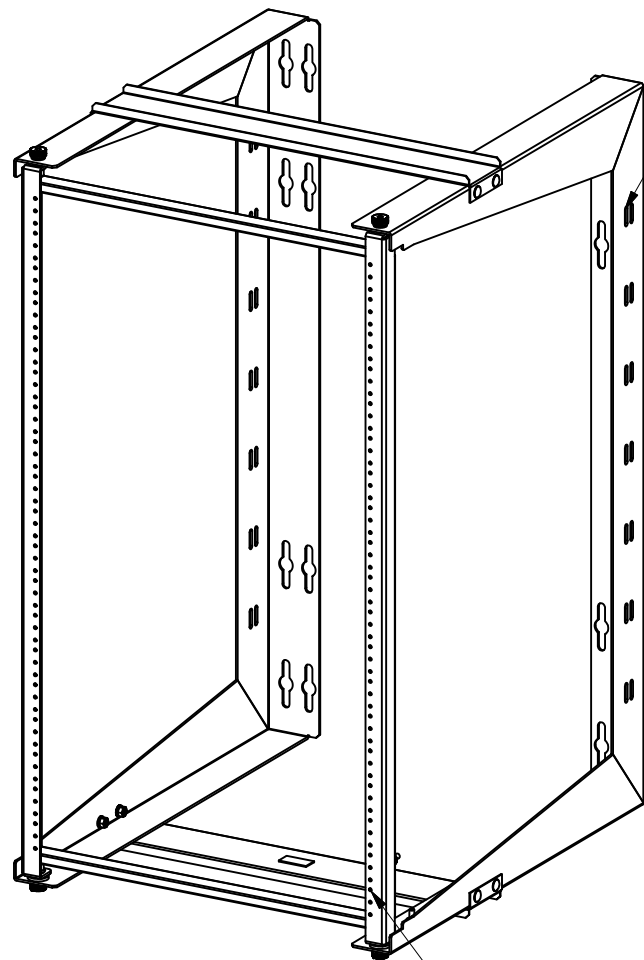

PROVISIONS FOR OPTIONAL
CM-01 - CABLE CINCH STRAPS

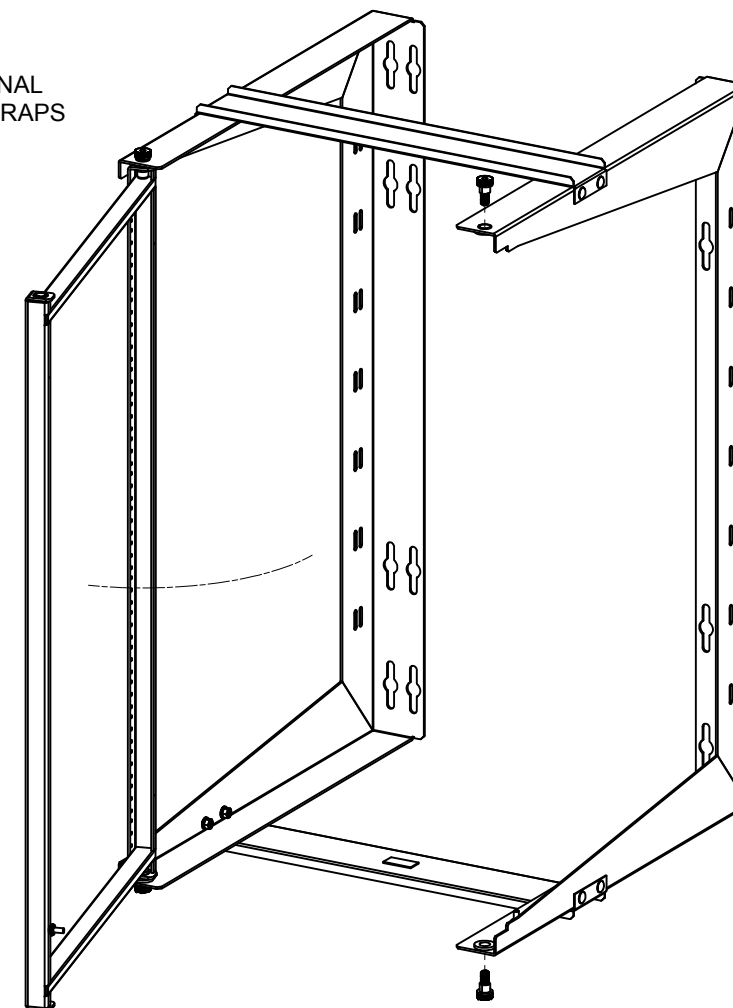

RACK PIVOTS FROM EITHER SIDE

#10-32 UNF - 2B
TAPPED HOLES FOR
EQUIPMENT MOUNTING

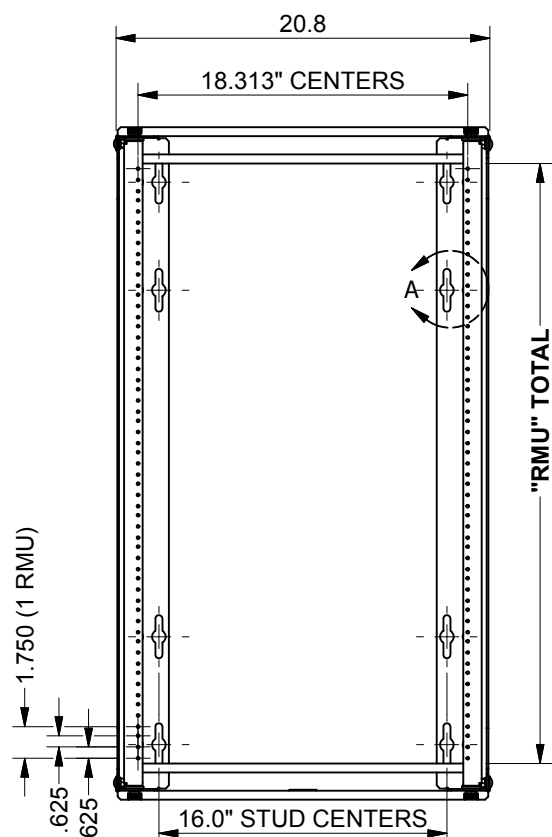

FRONT VIEW

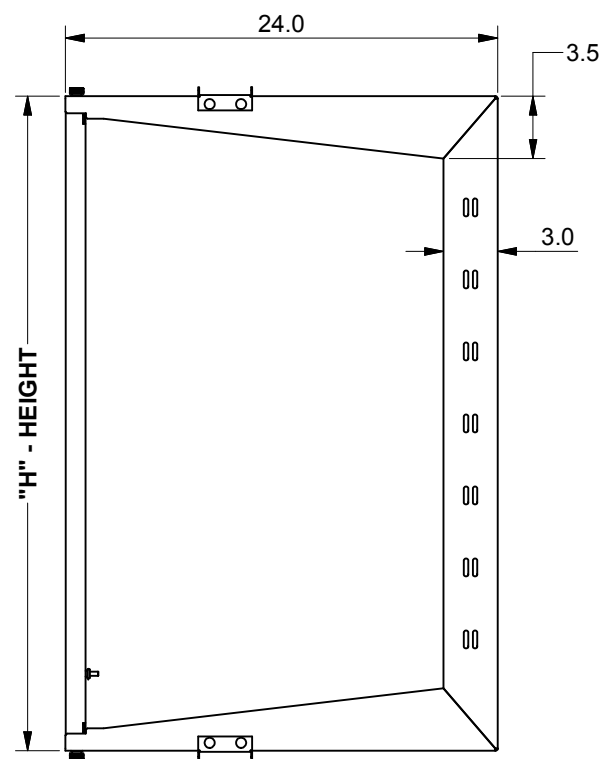

RIGHT SIDE VIEW

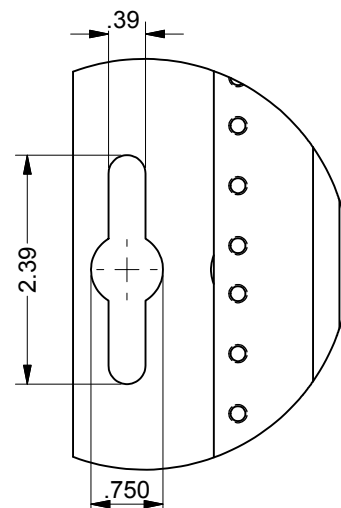

DETAIL A
TYP, WALL MOUNTING SLOTS

SPECIFICATIONS:

RACK SPACES: 19" EIA 310 COMPLIANT - SEE CHART

WEIGHT CAPACITY: 100 LBS - EVENLY DISTRIBUTED.

FINISH: DURABLE TEXTURED BLACK POWDER COATING.

CERTIFICATIONS: UL 60950-1 STANDARD FOR I.T. & COMMUNICATIONS EQ.

CONSTRUCTION: #12 GA. C.R.S. MOUNTING CHANNELS & SUPPORT FRAME.

USABLE DEPTH: 22" FROM MOUNTING SURFACE

HARDWARE: PACKAGE OF QTY-50; #10-32 x 1/2" LG. SCREWS INCLUDED.

PART NUMBER	RMU TOTAL	H - HEIGHT
24SRD3200	12	23.97
36SRD3200	19	36.22
48SRD3200	26	48.47

INTERPRET DRAWING PER ASME Y14.5M-1994
DIMENSIONAL LIMITS APPLY
AFTER APPLICATION OF FINISH
DRAWING NOT TO SCALE
TOLERANCE UNLESS OTHERWISE NOTED:
ANGULAR +/- .1"
.XXXX +/- .010
.XXX +/- .015
.XX +/- .030
.X FOR REF. ONLY
UNLESS OTHERWISE SPECIFIED
ALL DIMENSIONS ARE IN INCHES

NOTICE:

Use of this document is subject to a confidentiality and nondisclosure agreement with Great Lakes Case & Cabinet Co., Inc. (GLCC) and may not be reproduced, disclosed or utilized in whole or in part without prior written authorization from GLCC.

PART NUMBER:
SEE CHART
QTY PER UNIT: 1
MATERIAL TYPE:
C.R.S.
MATERIAL GAUGE:
VARIES
FINISH: POWDER COAT
DRAWN: DATE: 11/26/2008
FED: DATE: 12/8/2008
CHECKED & APP. DATE: 12/8/2008
WSS

TITLE: **WALL MOUNT SWING RACK, 19 RMU x 24"D ASSEMBLY**
GREAT LAKES CASE & CABINET CO., INC.
P.O. BOX 551 EDINBORO, PA 16412
PHONE (814) 734-7303 FAX (814) 734-3907
E-MAIL glcc@greatcabinets.com

DWG NO: 1007722
REV: 7
SHEET: 1 OF 1



THIRD ANGLE
PROJECTION