

# EVFT Illuminator long twin tube fluorescent luminaires

Cl. I, Div. 1, Groups B, C (with suffix GB), D  
Cl. I, Zone 1, Groups IIB + H<sub>2</sub> (with suffix GB), IIA  
Cl. II, Div. 1, Groups E, F, G  
Cl. III & Simultaneous Presence

Paint Spray  
Marine & Wet Locations  
3, 3R, 4, 4X; IP66

5L

## Applications:

EVFT Illuminator™ compact fluorescent luminaires are used:

- In areas made hazardous by the presence of flammable gases and vapors, combustible dusts or easily ignitable fibers and flyings
- In areas where combustible dusts and flammable gases are present simultaneously
- In applications involving low mounting heights, restricted mounting space or where luminaire weight must be minimized
- In areas where corrosion, vibration, moisture, dirt and rough usage are a problem
- In refineries, chemical and petrochemical facilities, grain processing, handling and storage facilities, manufacturing plants, wastewater treatment facilities, airline and mass transit maintenance areas, paint spray facilities, breweries, pharmaceutical plants and other areas where safe, reliable hazardous area lighting is required in a compact, cool operating and efficient light source

## Features:

- Efficient fluorescent light source in 78 and 156 watts
- Adjustable right and left asymmetrical reflectors provide excellent light "aimability" – ideal for task oriented lighting
- Compact, lightweight and low profile design allows easy installation and broad industrial application
- Cast copper-free aluminum with epoxy powder finish (less than 0.4 of 1% copper) provides excellent resistance to corrosion
- Versatile luminaire housing provides choice of pendant, wall or ceiling mount
- Suitable for paint spray areas; linear light source provides excellent color rendition for paint spray tasks; easy to install, disposable, clear tube wrap helps maintain maximum light output during painting operations
- Threaded construction, factory wiring and sealing help minimize installation time; no external seals are required
- Fixtures are used with two or four long twin tube single-ended fluorescent lamps
- Optional stainless steel guard provides extra protection for lamps and lamp tube
- Optional clear polycarbonate tube provides 360° protection for lamps and lamp tube; ideal for maintenance pit and pharmaceutical applications
- Grounding connection for safety
- Available for 120 or 277 VAC
- Standard electronic ballast

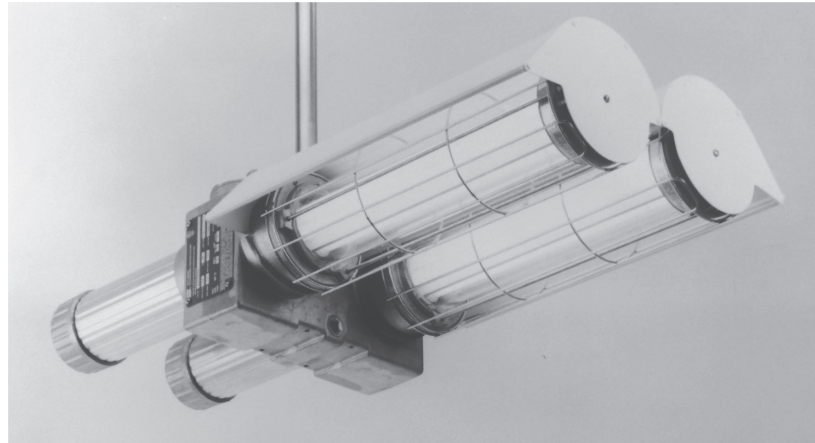

4-lamp with stainless steel wire guard and adjustable reflectors

## Certifications and compliances:

### NEC/CEC:

- Class I, Division 1, Group D
- Class I, Division 1, Groups B, C, D (with suffix GB)
- Class I, Zone 1, Group IIA
- Class I, Zone 1, Group IIB + H<sub>2</sub> (with suffix GB)
- Class II, Division 1, Groups E, F, G
- Class III
- Simultaneous Presence (Class I and Class II)
- Paint Spray

### Note: Aiming limitations

- Class II, Class III & Simultaneous Presence
- Aim down to horizontal
- Cannot aim up

### UL standards:

- UL844 – Hazardous (Classified) Locations
- UL1598 – Luminaires
- UL1598A – Marine Locations

### CSA standard:

- C22.2 No. 137

## Standard materials:

- Center and ballast housings, end caps – copper-free aluminum
- Lamp tube – heat-resistant glass
- Guards – stainless steel or clear polycarbonate
- Reflectors – aluminum

## Standard finishes:

- Center and ballast housings, end caps, guards – natural
- Reflectors – white epoxy finish

## Electrical ratings:

- Input voltage – 120 or 277 VAC, 60 Hz
- Wattages – 78W: 2-lamp luminaire; 156W: 4-lamp luminaire

## Photometrics:

- Complete photometrics can be found at [www.crouse-hinds.com/photometrics](http://www.crouse-hinds.com/photometrics)

## Options:

Description	Suffix
• Fused – to protect circuit under abnormal line conditions.....	<b>S658</b>
<i>Not available on CSA certified fixtures Not suitable for marine applications</i>	
• Luminaire supplied with lamps.....	<b>S714</b>
• Class I, Groups B, C suitability.....	<b>GB</b>
<i>Available on pendant mount fixtures only</i>	

## Accessories (ordered separately):

Description	Cat. #
• Stainless steel wire guard.....	<b>P51</b>
• Reflector right hand.....	<b>RAR1</b>
• Reflector left hand.....	<b>RAL1</b>
• Polycarbonate tube.....	<b>PG1</b>
<i>Not used with optional stainless steel wire guard</i>	
• Disposable clear wrap – 5 pack.....	<b>PTW1</b>
<i>For use with optional polycarbonate tube</i>	

## Weights:

Type	Weight (lbs.)
2-lamp with guard	19.50
4-lamp with guards	36.50
RAL1, RAR1 reflectors	3.00 (each)

**Deduct:** 1.00 lb. for 2-lamp fixture without P51 guard; 2.00 lbs. for 4-lamp fixture without P51 guard

# EVFT Illuminator long twin tube fluorescent luminaires

Cl. I, Div. 1, Groups B, C (with suffix GB), D  
Cl. I, Zone 1, Groups IIB + H<sub>2</sub> (with suffix GB), IIA  
Cl. II, Div. 1, Groups E, F, G  
Cl. III & Simultaneous Presence

Paint Spray  
Marine & Wet Locations  
3, 3R, 4, 4X; IP66

5L

## Ordering information:

Style	Hub size	Luminaire voltage	Class I with Group D suitability		Class I with Groups B, C, D suitability	
			Cat. # Without guard	Cat. # With P51 guard <sup>A</sup>	Cat. # Without guard	Cat. # With P51 guard <sup>A</sup>
2-lamp	3/4"	120	EVFT22320	EVFT22321	EVFT22320 GB	EVFT22321 GB
	3/4"	277	EVFT22370	EVFT22371	EVFT22370 GB	EVFT22371 GB
4-lamp	3/4"	120	EVFT24320	EVFT24321	EVFT24320 GB	EVFT24321 GB
	3/4"	277	EVFT24370	EVFT24371	EVFT24370 GB	EVFT24371 GB

## Accessories (ordered separately):



RAL1, RAR1 reflectors (as viewed facing front of fixture)

Note: For 4-lamp unit, you must order one of each refractor, if required.

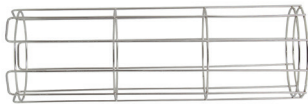

Stainless steel guard



Polycarbonate tube and retaining plate

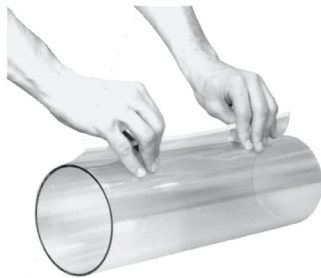

Disposable polyester tube wrap (used over optional polycarbonate tube)

## Aiming limitations:

In Class II, Class III and Simultaneous Presence locations:

- Aim down to horizontal
- To prevent dust from accumulating in reflector, do not aim up
- Illuminator lighting fixtures are designed for operation with the lamp in a horizontal to base down position

## Temperature performance data:

Luminaire type	Minimum operating temp.	Maximum ambient	Class I, Div. 1 & Zone 1; Class II, Div. 1; Simultaneous Presence	Supply wire °C
2- and 4-lamp	10°C (50°F)	40°C (104°F)	T4A	75

## Dimensions:

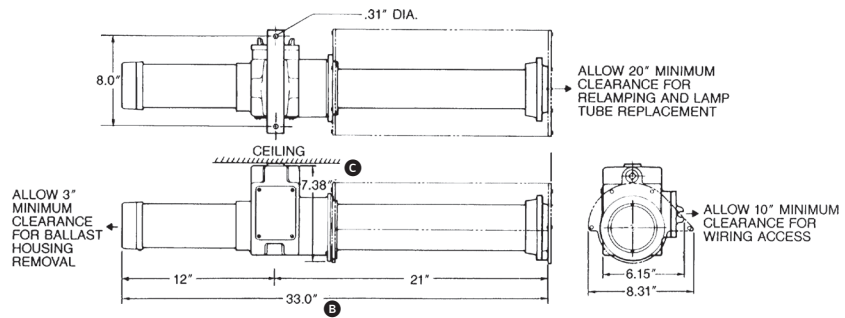

2-lamp luminaire with reflector

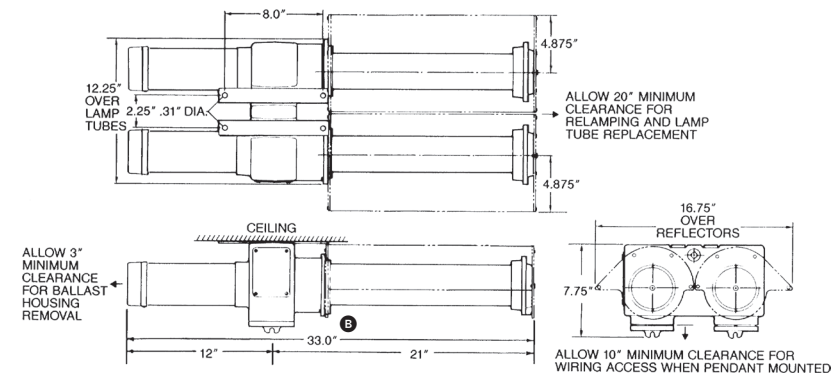

4-lamp luminaire with reflectors

<sup>A</sup>P51 supplied in separate carton.

<sup>B</sup>For GB suffix (Groups B and C), this dimension is 34.00". For CSA certified fixtures, this dimension is 35.56".

<sup>C</sup>For GB suffix (Groups B and C), this dimension is 8.38".