

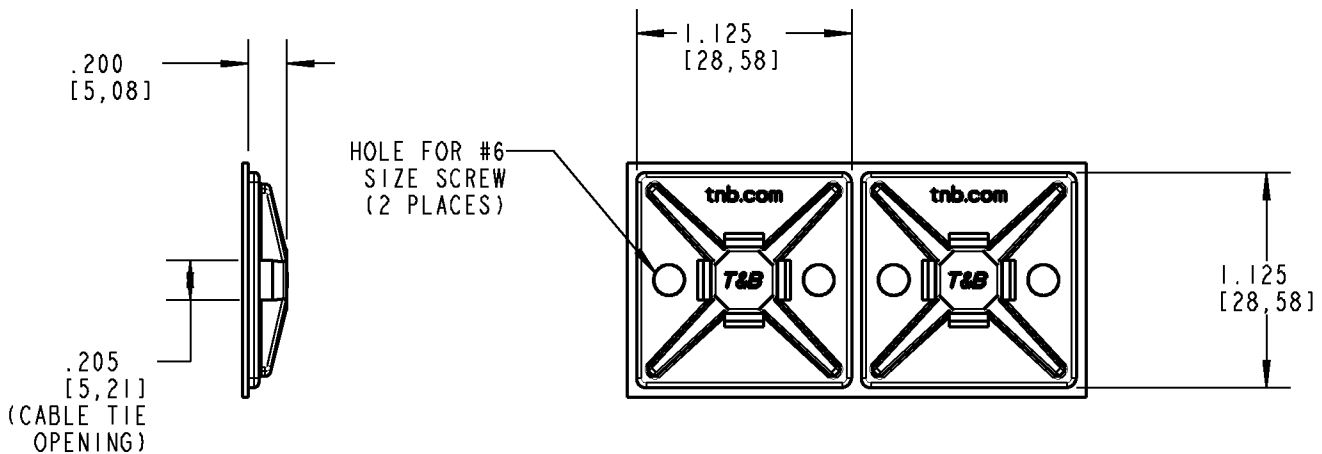

CABLE FASTENING ACCESSORIES



SPECIFICATIONS:

MATERIAL: NYLON

ADHESIVE: SYNTHETIC RUBBER RESIN OR SOLVENT-BASED ACRYLIC (AS INDICATED)

APPLICATION TEMPERATURE: 65°F TO 120°F (18°C TO 49°C)
STORAGE/SERVICE TEMPERATURE: 32°F TO 150°F (0°C TO 65°C)

SURFACE PREPARATION: SURFACE SHOULD BE CLEANED WITH ALCOHOL-BASED (IPA) CLEANER BEFORE APPLICATION.

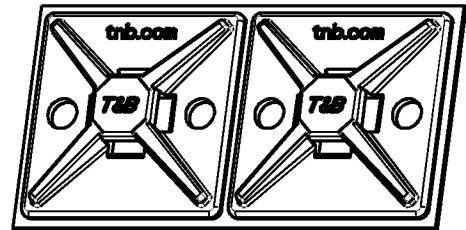

NOTES.

1. ACRYLIC BASED MOUNTS MAY BE REPOSITIONED INITIALLY. ALLOW 24-72 HOURS SET-UP FOR MAXIMUM PERFORMANCE ADHESION.
2. FOR RUBBER-BASED MOUNTS, ALLOW 15 MINUTES SET-UP FOR MAXIMUM PERFORMANCE ADHESION.
3. EXPIRATION DATE INDICATED ON PACKAGING.

CAT. No.	MATERIAL	MOUNTING METHOD	COLOR
MPNY-1000-9-*	NYLON NATURAL	SYNTHETIC RUBBER ADHESIVE	WHITE
MPNY-1000-0-*	NYLON WEATHERABLE	SYNTHETIC RUBBER ADHESIVE	BLACK
MPNY-1000A-9-*	NYLON NATURAL	ACRYLIC ADHESIVE	WHITE
MPNY-1000A-0-*	NYLON WEATHERABLE	ACRYLIC ADHESIVE	BLACK
MPNY-1000S-9-*	NYLON NATURAL	SCREW MOUNT	WHITE
MPNY-1000S-0-*	NYLON WEATHERABLE	SCREW MOUNT	BLACK

* DENOTES PACK QTY. "C"= 100, "D"= 500

GENERAL NOTES		Thomas & Betts www.tnb.com			
1. ALL DIMENSIONS ARE FOR REFERENCE ONLY. 2. DIMENSIONS IN BRACKETS [] ARE IN METRIC UNITS.					
REVISIONS		DESCRIPTION: CABLE TIE MOUNTING BASE			
- SEE ERN (****) FOR APPROVAL SIGNATURES & RELEASE DATE. PROJECT NO: ****					
		ORIGINAL PROJECT NO / (ERN NO)	SHEET NO:	REV. NO:	DRAWING NO:
		FM40109 / (2004200)	1 OF 1	-	WSD-000069