



*Allen-Bradley*

## **Pico™ Controller**

**Bulletin 1760**

**Getting Results**

**Rockwell  
Automation**

## Important User Information

Solid state equipment has operational characteristics differing from those of electromechanical equipment. *Safety Guidelines for the Application, Installation and Maintenance of Solid State Controls* (Publication SGI-1.1 available from your local Rockwell Automation sales office or online at <http://www.ab.com/manuals/gi>) describes some important differences between solid state equipment and hard-wired electromechanical devices. Because of this difference, and also because of the wide variety of uses for solid state equipment, all persons responsible for applying this equipment must satisfy themselves that each intended application of this equipment is acceptable.

In no event will Rockwell Automation, Inc. be responsible or liable for indirect or consequential damages resulting from the use or application of this equipment.

The examples and diagrams in this manual are included solely for illustrative purposes. Because of the many variables and requirements associated with any particular installation, Rockwell Automation, Inc. cannot assume responsibility or liability for actual use based on the examples and diagrams.

No patent liability is assumed by Rockwell Automation, Inc. with respect to use of information, circuits, equipment, or software described in this manual.

Reproduction of the contents of this manual, in whole or in part, without written permission of Rockwell Automation, Inc. is prohibited.

Throughout this manual, when necessary we use notes to make you aware of safety considerations.

---

**WARNING**

Identifies information about practices or circumstances that can cause an explosion in a hazardous environment, which may lead to personal injury or death, property damage, or economic loss.

---

**IMPORTANT**

Identifies information that is critical for successful application and understanding of the product.

---

**ATTENTION**

Identifies information about practices or circumstances that can lead to personal injury or death, property damage, or economic loss. Attentions help you:

- identify a hazard
- avoid a hazard
- recognize the consequence

---

**SHOCK HAZARD**

Labels may be located on or inside the equipment (e.g., drive or motor) to alert people that dangerous voltage may be present.

---

**BURN HAZARD**

Labels may be located on or inside the equipment (e.g., drive or motor) to alert people that surfaces may be dangerous temperatures.

---

<b>Preface</b>	Who Should Use this Manual. . . . .	Preface-i
	Purpose of This Manual. . . . .	Preface-ii
	Common Techniques Used in this Manual . . . . .	Preface-ii
	Rockwell Automation Support . . . . .	Preface-iii
	 <b>Chapter 1</b>	
<b>Pico Controller</b>	Safety Information. . . . .	1-1
	Simply Pico. . . . .	1-1
	Mount Pico. . . . .	1-3
	Connect Pico . . . . .	1-4
	Pico Operating Principle . . . . .	1-10
	Menu Structure . . . . .	1-15
	 <b>Chapter 2</b>	
<b>Drawing a Circuit with Pico</b>	Operation of Pico . . . . .	2-1
	Set the Menu Language . . . . .	2-2
	Set the Time . . . . .	2-3
	Choose Pico Operating Mode . . . . .	2-4
	Pico Circuit Diagram Elements. . . . .	2-5
	Example: Creating a Circuit Diagram . . . . .	2-9
	Function Relay Types . . . . .	2-13
	Example: Use a Function Relay . . . . .	2-20
	Basic Circuits . . . . .	2-23
	 <b>Chapter 3</b>	
<b>Pico Interface Socket</b>		
	 <b>Appendix A</b>	
<b>Specifications</b>	Physical Specifications. . . . .	A-1
	Product Selection Table. . . . .	A-1
	Accessories. . . . .	A-3
	Dimensions. . . . .	A-4
	 <b>Index</b>	



Read this preface to familiarize yourself with the rest of the manual. It provides information concerning:

- who should use this manual
- the purpose of this manual
- related documentation
- conventions used in this manual
- Rockwell Automation support

### **Who Should Use this Manual**

Use this manual if you are responsible for designing, installing, programming, or troubleshooting control systems that use Pico controllers.

You should have a basic understanding of electrical circuitry and familiarity with relay logic. If you do not, obtain the proper training before using this product.

## Purpose of This Manual

This manual provides a basic overview of Pico and an introduction to Pico programming. For a more detailed description of how to install and use your Pico Controller, refer to publication 1760-UM001, Pico Controller User Manual.

## Related Documentation

The following documents contain additional information concerning Rockwell Automation products. To obtain a copy, contact your local Rockwell Automation office or distributor.

For	Read this Document	Document Number
A more detailed description of how to install and use your Pico controller.	Pico Controller User Manual	1760-UM001
In-depth information on grounding and wiring Allen-Bradley programmable controllers	Allen-Bradley Programmable Controller Grounding and Wiring Guidelines	1770-4.1
A description of important differences between solid-state programmable controller products and hard-wired electromechanical devices	Application Considerations for Solid-State Controls	SGL-1.1
An article on wire sizes and types for grounding electrical equipment	National Electrical Code - Published by the National Fire Protection Association of Boston, MA.	
A complete listing of current documentation, including ordering instructions. Also indicates whether the documents are available on CD-ROM or in multi-languages.	Allen-Bradley Publication Index	SD499
A glossary of industrial automation terms and abbreviations	Allen-Bradley Industrial Automation Glossary	AG-7.1

## Common Techniques Used in this Manual

The following conventions are used throughout this manual:

- Bulleted lists such as this one provide information, not procedural steps.
- Numbered lists provide sequential steps or hierarchical information.
- Italic type is used for emphasis.

## Rockwell Automation Support

Rockwell Automation offers support services worldwide, with over 75 Sales/Support Offices, 512 authorized Distributors and 260 authorized Systems Integrators located throughout the United States alone, plus Rockwell Automation representatives in every major country in the world.

### Local Product Support

Contact your local Rockwell Automation representative for:

- sales and order support
- product technical training
- warranty support
- support service agreements

### Technical Product Assistance

If you need to contact Rockwell Automation for technical assistance, please review the Troubleshooting chapter in the Pico Controller User Manual first. Then call your local Rockwell Automation representative.

You can also contact Rockwell Automation Technical Support. To reach our Technical Support, go to the following website to find the support site for your region.

- <http://support.automation.rockwell.com/contactinformation/>

### Your Questions or Comments on this Manual

If you find a problem with this manual, or you have any suggestions for how this manual could be made more useful to you, please contact us at the address below:

Rockwell Automation  
Control and Information Group  
Technical Communication, Dept. A602V  
P.O. Box 2086  
Milwaukee, WI 53201-2086

or visit our internet page at:  
<http://www.ab.com/pico> or <http://www.rockwellautomation.com>





## Pico Controller

### Safety Information

#### ATTENTION



#### Electrical Shock Hazard

The electrical installation and commissioning work must only be carried out by suitably qualified personnel.

Do not work on the device when the power is turned on.

Observe the relevant safety regulations:

- Turn off the power
- Make sure that the device cannot be powered on again inadvertently
- Check to make sure that no dangerous voltages are present before working on the device

### Simply Pico

#### Clever Switching and Controlling

Pico is a compact, user-friendly and low-cost controller for simple control applications. Applications range from building and domestic automation to machine and plant control. Pico has built-in user-friendly operating elements and an LCD display.

Connect Pico and draw a circuit diagram on the display by pressing the buttons on the device. Pico works with make contacts, break contacts, and relays.

Enter a circuit diagram in Pico just like it is sketched on paper. Pico has basic and advanced functions for relays, time switches and contactors, among other functions. Make changes to the circuit by pressing the buttons on the device. Time consuming rewiring is not necessary.

## Applications Everywhere

- Building and domestic automation, controllers for lighting, doors, window shutters
- Control ventilators, rotating doors, greenhouses, exterior lighting, window controllers, shop display lighting
- Create controllers for temperature, ventilation and brightness levels
- Control machines and plant, presses, conveyor belts, oscillating conveyors, sorters, pumps

## Overview of Pico

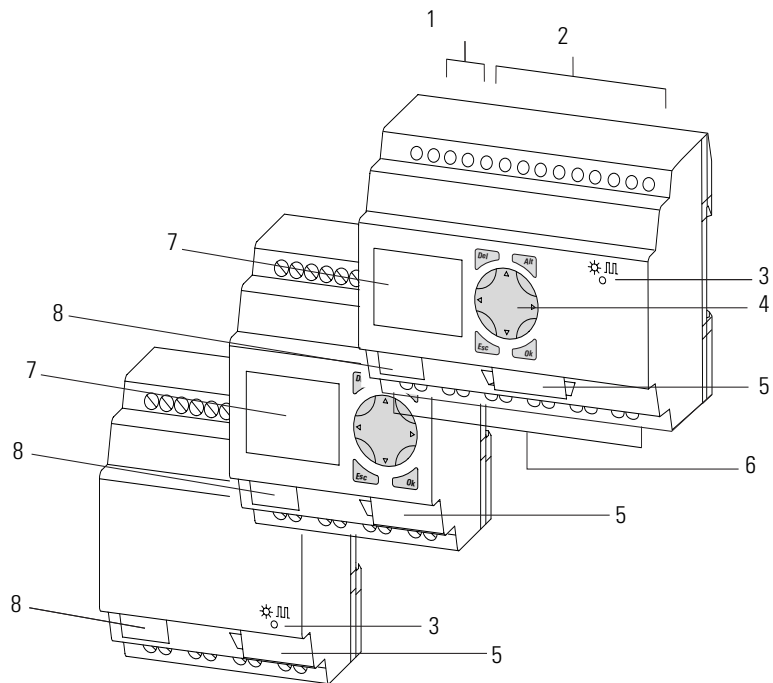

Item	Description
1	Incoming Power
2	Inputs
3	Power/Run LED
4	Keypad
5	Socket for memory module or PC interface cable
6	Outputs
7	LCD display
8	Write-On Surface

## Mount Pico

### Mount on DIN Rail

1. Hook Pico to the top edge of the DIN rail and rotate into place while pressing down slightly as shown by the arrow.
2. Pico will clip into place and is secured by the built-in spring mechanism.

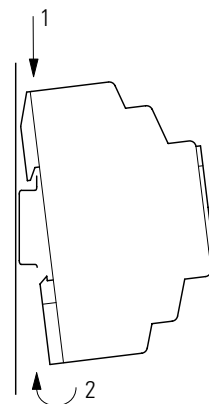

### Mount on a Mounting Plate

Pico can be screwed to a mounting plate with the three or four feet which are included.

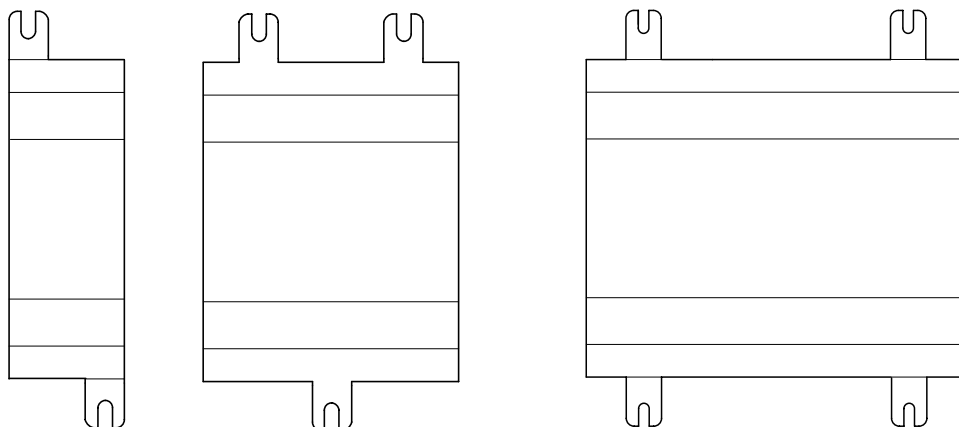
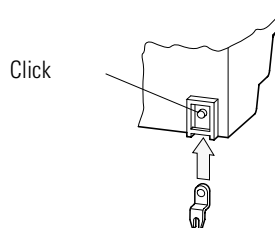

## Connect Pico

### Pico Inputs 1760-L12BBB-xx, 1760-L12BWB-xx and 1760-L12DWD-xx

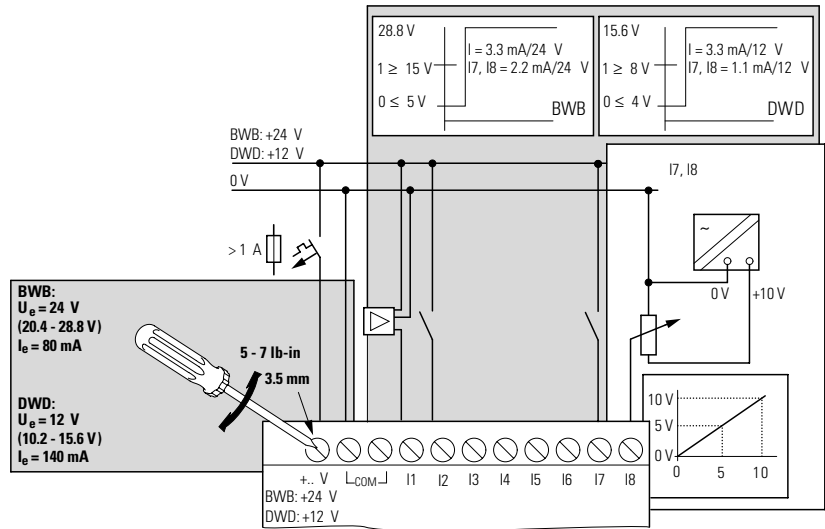

### Pico Inputs 1760-L12AWA-xx and 1760-L12NWA-xx

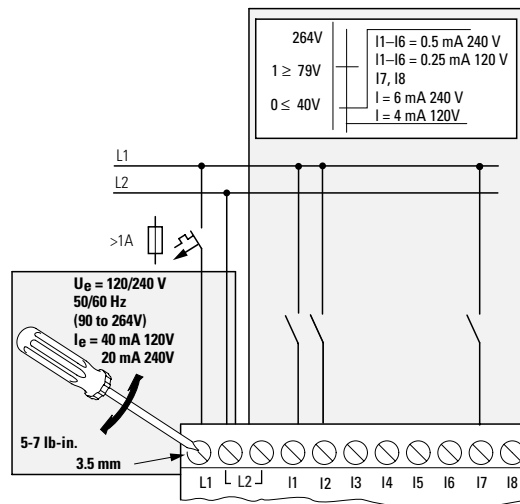

### Pico Outputs 1760-L12AWA-xx, 1760-L12BWB-xx, 1760-L12DWD-xx, 1760-L12BBB-xx and 1760-L12NWA-xx

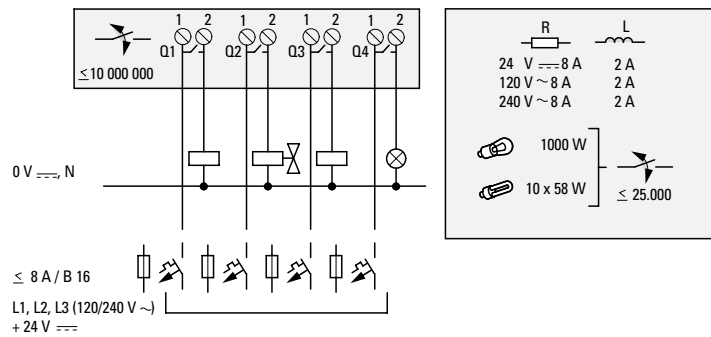

### Pico Inputs 1760-L18BWB-EX and 1760-L18BWB-EXND

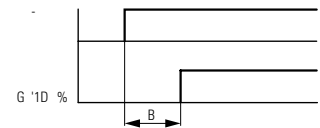
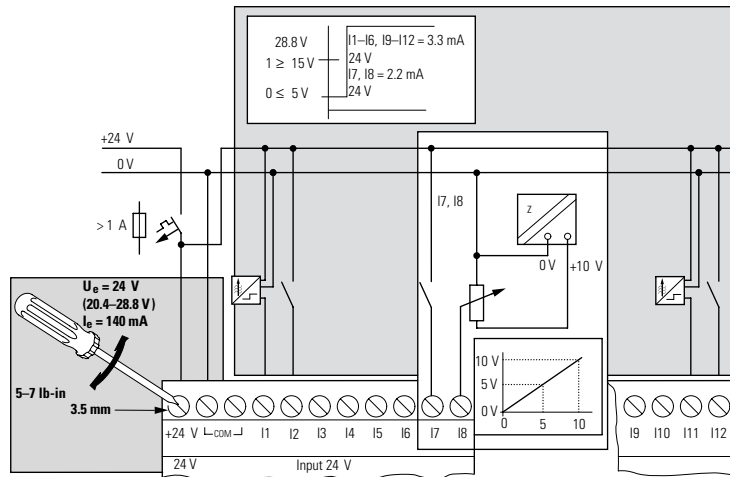

### Pico Inputs 1760-L18AWA-xx and 1760-L18NWA-xx

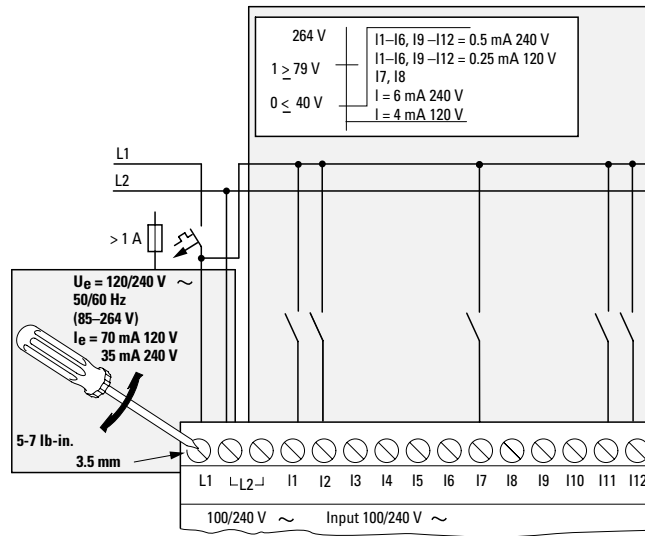

### Pico Outputs 1760-L18xxx

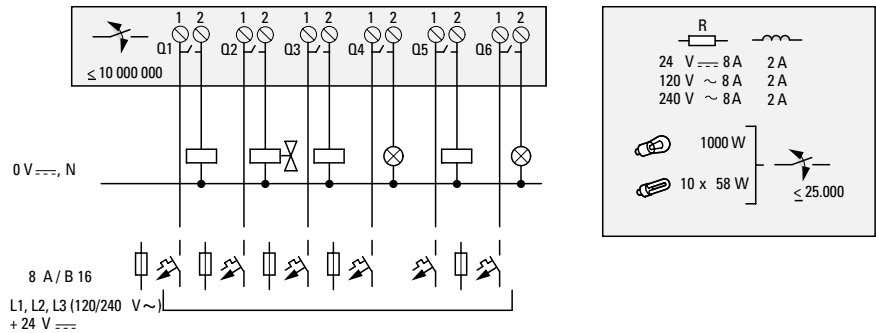

### Pico Inputs 1760-L20xxx

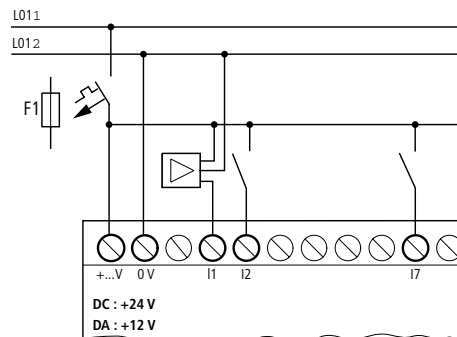

### Pico Outputs 1760-L20xxx

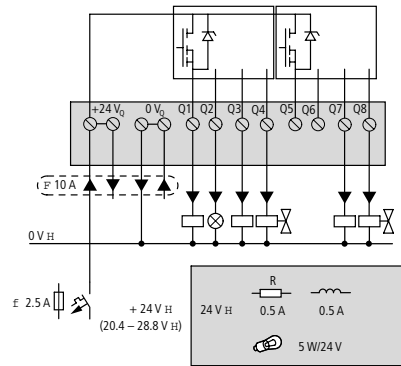

### Pico Inputs 1760-IB12X0B8

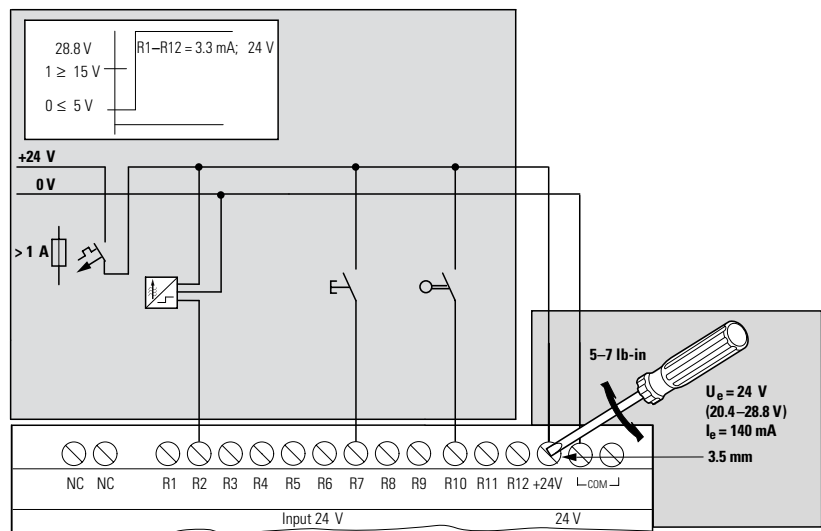

### Pico Outputs 1760-IB12X0B8

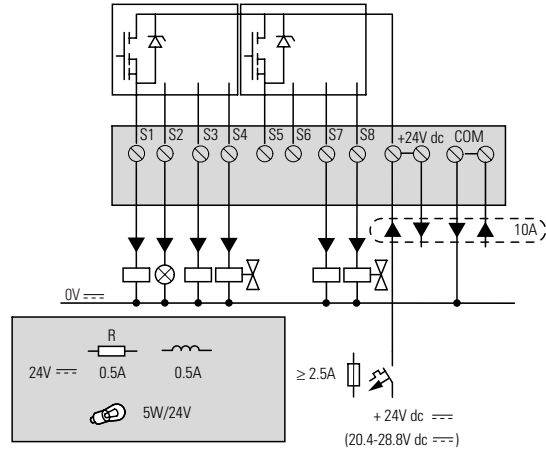

### Pico Inputs 1760-IA12X0W6I and 1760-IB12X0W6I

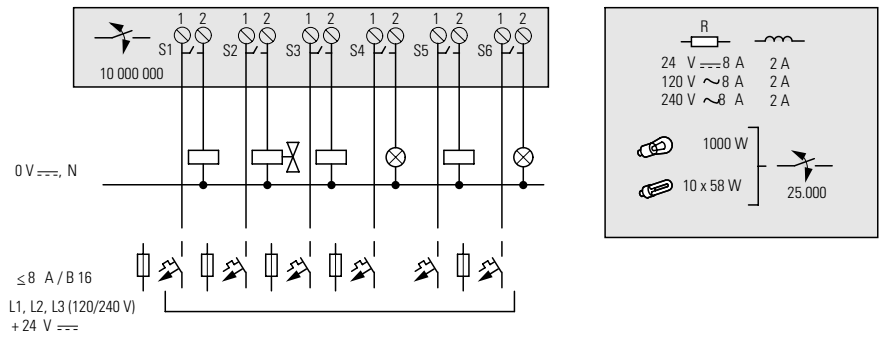



### Pico Outputs 1760-IA12XOW6I and 1760-IB12XOW6I

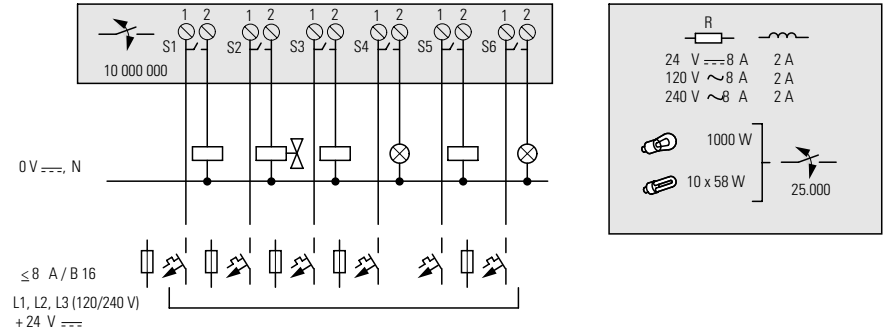

### Pico Outputs 1760-OW8

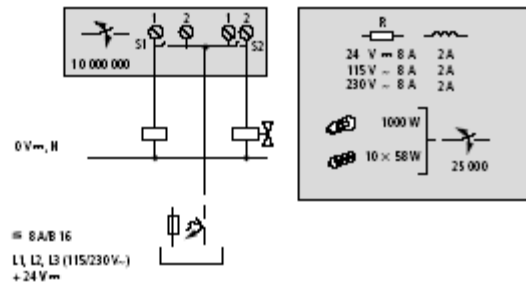



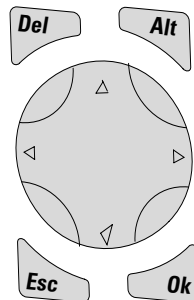

## Pico Operating Principle

## Pico Operating Buttons



Button	Function
<i>Del</i>	Delete object in the circuit diagram
<i>Alt</i>	Special functions in the circuit diagram
Cursor Buttons	Move cursor
	Select menu item
	Choose contact numbers, values, times, etc.
<i>Ok</i>	Next menu level, store your entry
<i>Esc</i>	Previous menu level, cancel your entry

## Move Through Menus to Choose Values

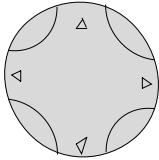
Press	To
 and 	Show system menu (press both keys at the same time).
	<ul style="list-style-type: none"> <li>• Go to next menu level.</li> <li>• Select menu item.</li> <li>• Store your entry.</li> </ul>
	Cancel your entry since the last <i>Ok</i> .
	<ul style="list-style-type: none"> <li>• Change menu item.</li> <li>• Change value.</li> <li>• Change position.</li> </ul>

## 12-Point Status Display

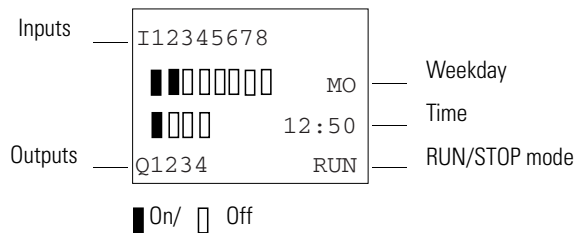

## 18-Point and 20-Point Status Display

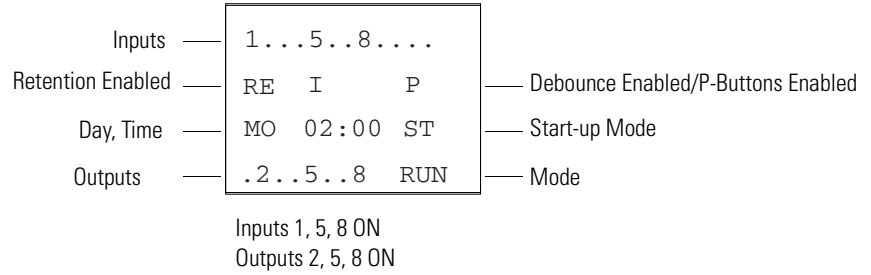

## Menu Display

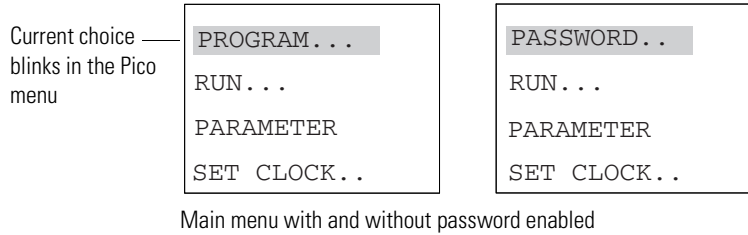

## Cursor Display

There are two different cursor types:

Full block navigation is shown as a flashing block:

- Move cursor with the left/right arrows
- When in circuit diagram, also use up/down arrows

Parameter change cursor flashes the selected parameter:

- Change position with left/right arrows
- Change values with up/down arrows

Flashing values/menus are highlighted in grey in this manual.

WINTER	TIME
DAY :	MO
TIME :	01■25

WINTER	TIME
DAY :	MO
TIME :	01:25

## Circuit Diagram Menu

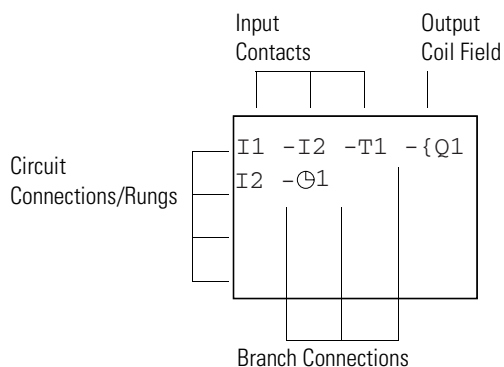

Each rung can hold four instructions, three input instructions (contacts) and one output instruction (coil or relay). Rungs are connected together through branches at the three positions between instructions. All programming of Pico can be done using the display and keypad.

## Circuit Diagram Symbols

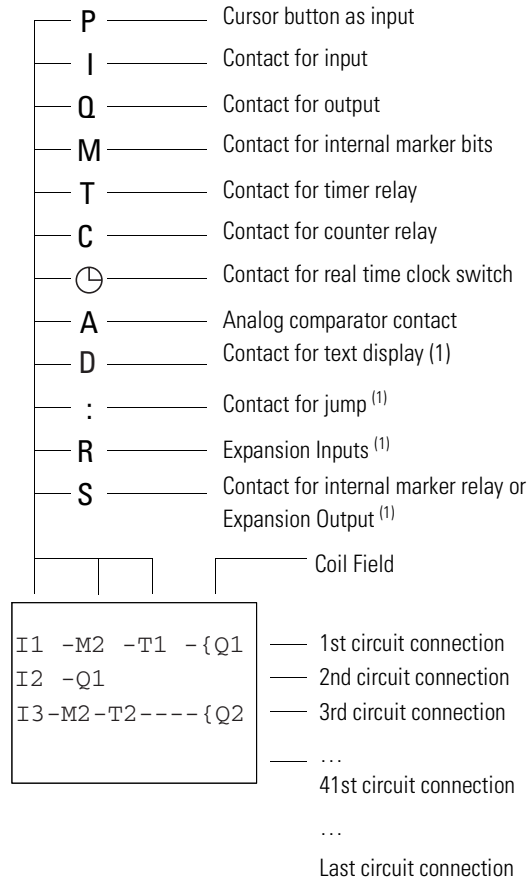

(1) For 1760-L18xxx only

# Menu Structure

## Main Menu Without Optional Password Protection

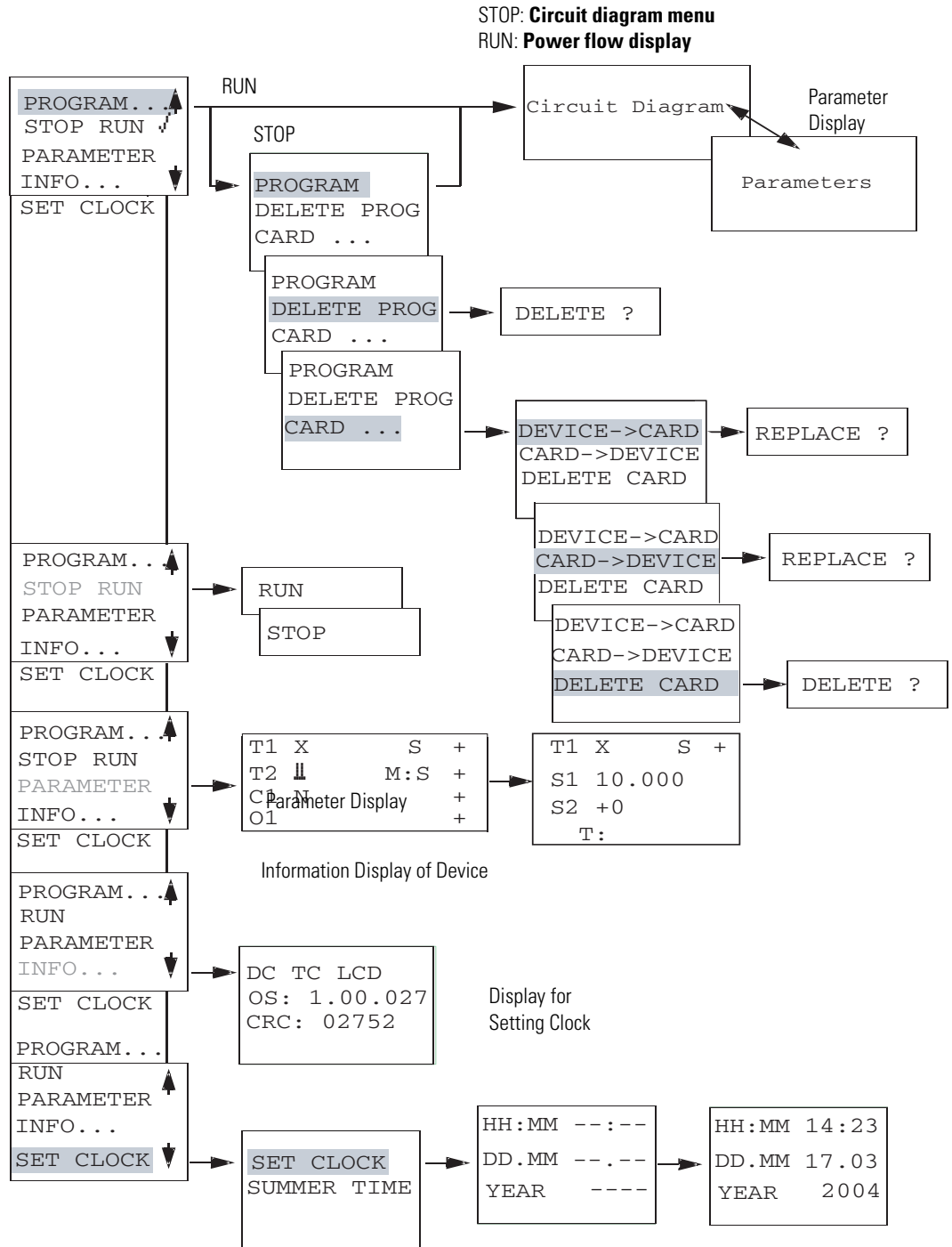

## Main Menu Setting Summer Time

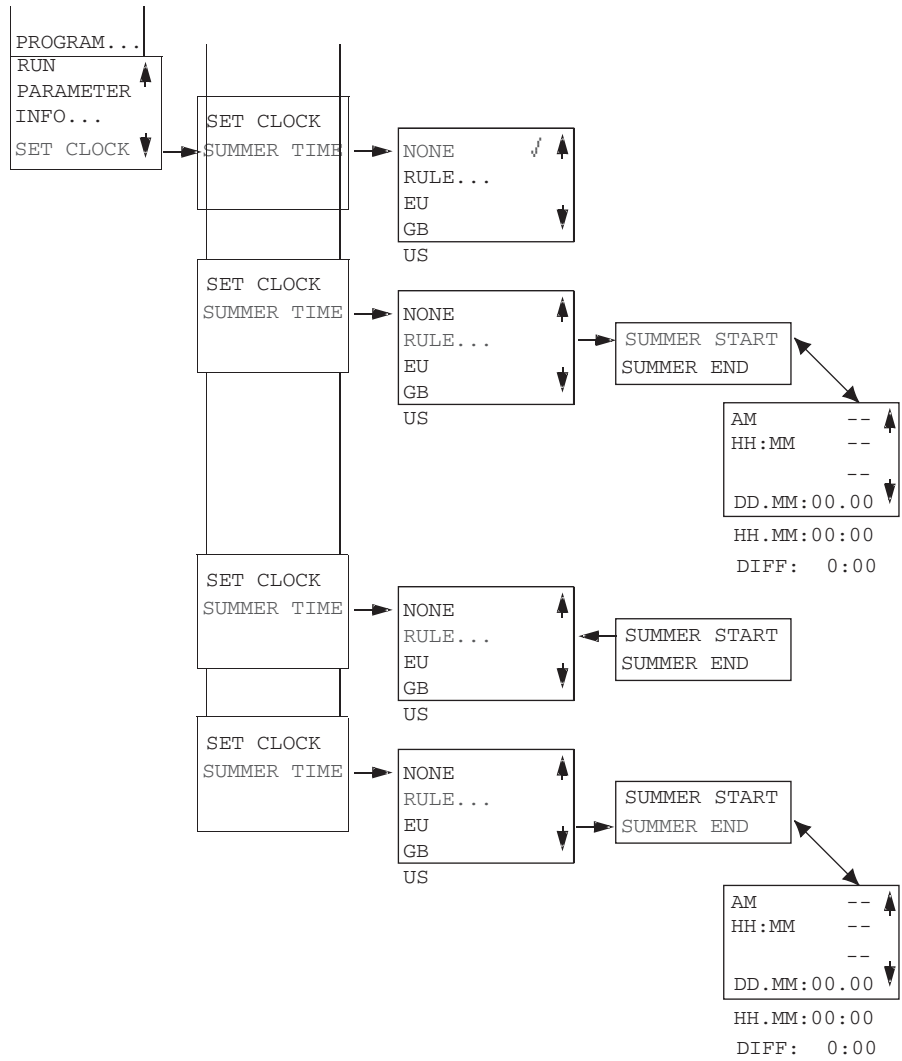



## Main Menu with Password Protection

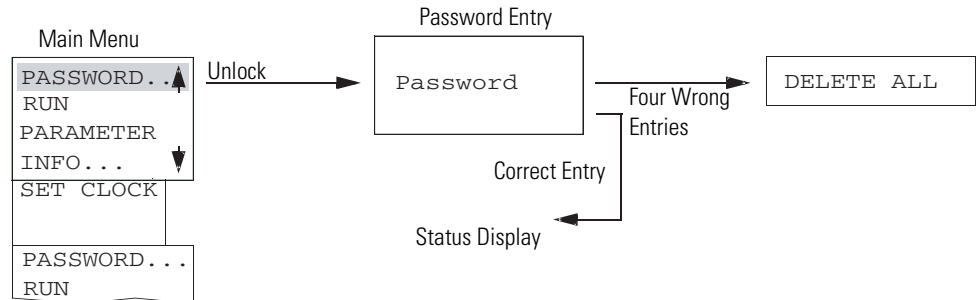

### TIP

If you do not know the password, you can delete the old password, but the circuit diagram and data will also be deleted. To delete the password, press **Ok** to DELETE ALL after entering four incorrect passwords. (Pressing **Esc** retains the circuit diagram and data. You can then make another four attempts to enter the password.)



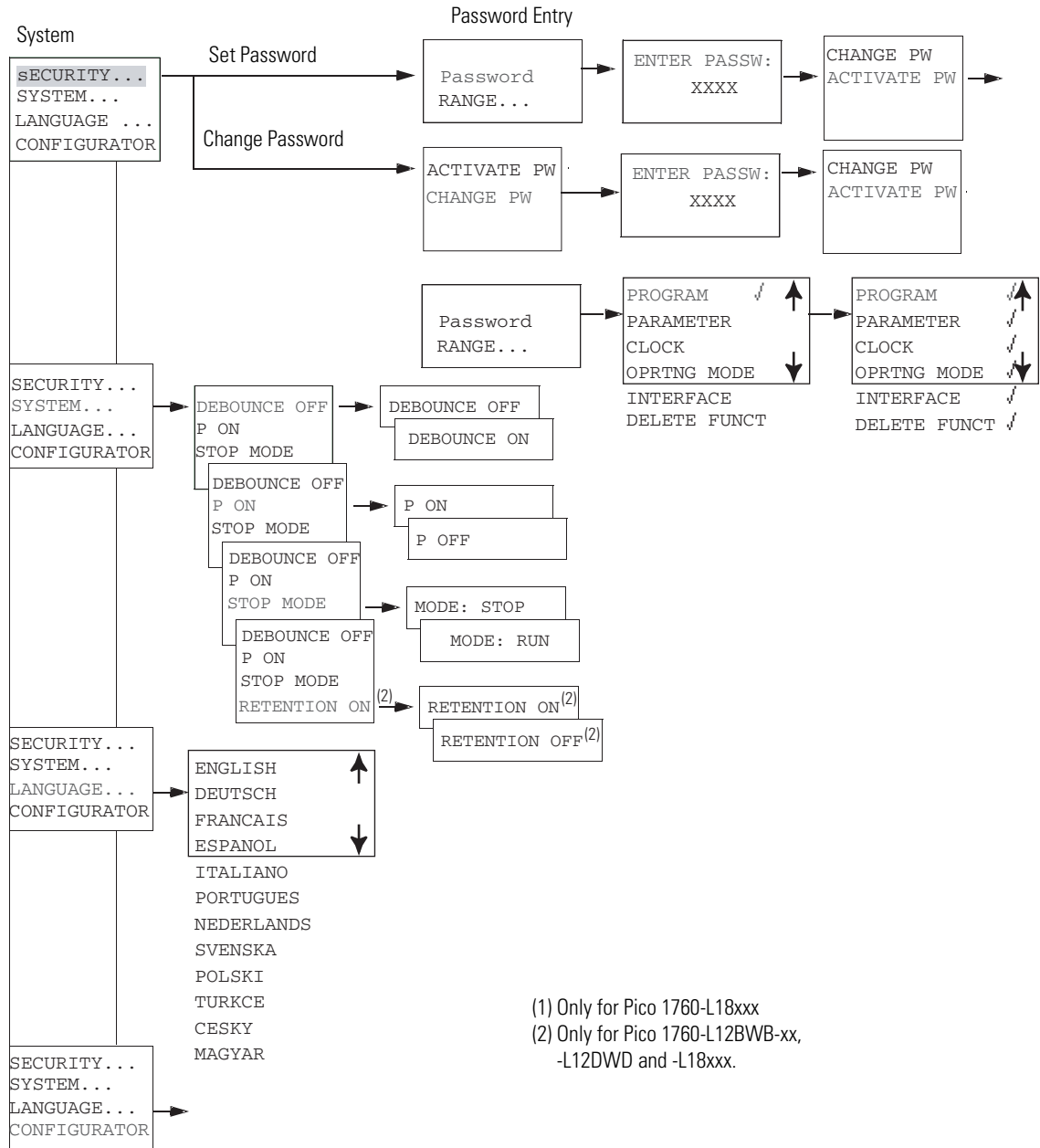

## System Menu



## Drawing a Circuit with Pico

### Operation of Pico

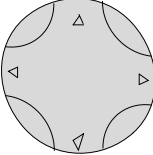
### Buttons for Drawing Circuit Diagrams

Button	Function
	Delete branch, contact, relay, or empty rung in the circuit diagram
	<ul style="list-style-type: none"> <li>• Toggle between break and make contact</li> <li>• Connect contacts and relays</li> <li>• Add circuit connections</li> </ul>
	<p>Up/down arrows:</p> <ul style="list-style-type: none"> <li>• Change value</li> <li>• Move cursor up and down</li> </ul> <p>Left/right arrows:</p> <ul style="list-style-type: none"> <li>• Move cursor to left and right</li> <li>• Change between parameters</li> </ul>
	<ul style="list-style-type: none"> <li>• Go to previous menu level</li> <li>• Undo settings from previous Ok</li> <li>• Exit current display</li> </ul>
	<ul style="list-style-type: none"> <li>• Go to next menu level</li> <li>• Change, add contact/relay</li> <li>• Save setting</li> </ul>

## Set the Menu Language

## Power Up Pico for the First Time

**TIP**

A brief current surge is produced when powering on the unit for the first time. Do not switch the unit using reed contacts, since these may burn or melt.

When you power-up Pico for the first time, you are asked to select the menu language.

Use the up and down cursor buttons to select a language. Definitions of the language abbreviations are shown below.

Language	LCD display	Abbreviaton
English	ENGLISH	GB
German	DEUTSCH	D
French	FRANCAIS	F
Spanish	ESPANOL	E
Italian	ITALIANO	I
Portuguese	PORTUGUES	–
Dutch	NEDERLANDS	–
Swedish	SVENSKA	–
Polish	POLSKI	–
Turkish	TURKCE	–
Czexh	CESKY	–
Hungarian	MAGYAR	–

ENGLISH	↑
DEUTSCH	
FRANCAIS	↓
ESPANOL	
ITALIANO	
PORTUGUES	
NEDERLANDS	
SVENSKA	
POLSKI	
TURKCE	
CESKY	
MAGYAR	

Press **Ok** to confirm your choice or press **Esc** to exit the menu. The unit then switches to the status display. You can also change the language setting at a later date.

If you do not set the language, Pico displays this menu and waits for you to select a language every time the unit is powered up.

## Set the Time

Controllers with the “-NC” designation do not have real time clocks.

### Set the Real Time Clock

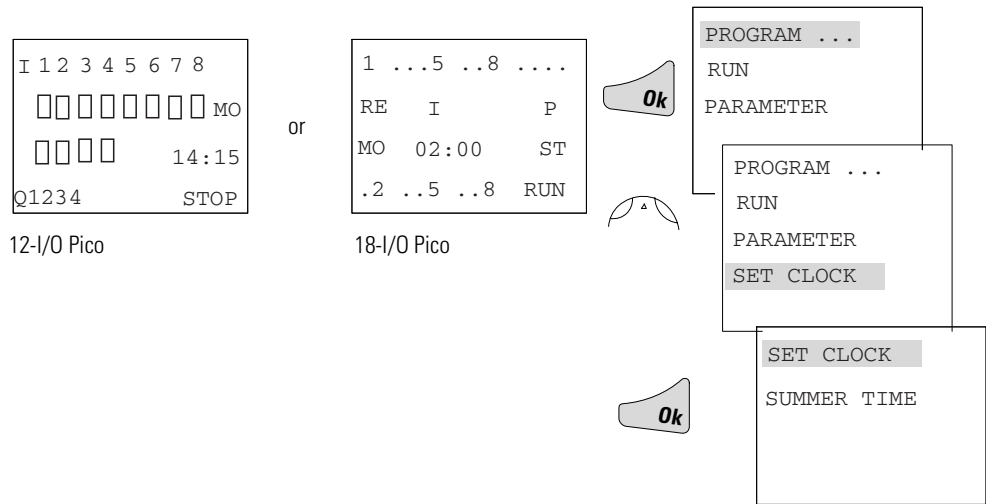

### Set Week Day and Time

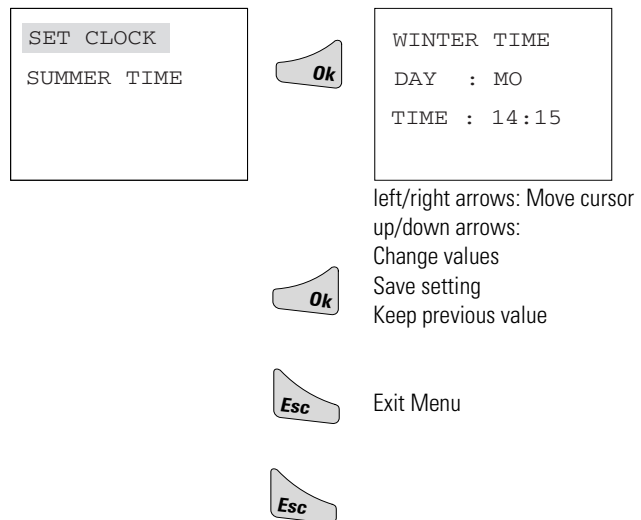

## Winter/Summer Time (Daylight Savings Time)

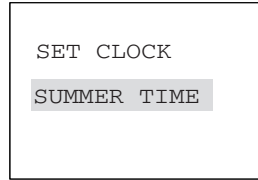

Display: SUMMER TIME  
 Winter time is set  
 Display: WINTER TIME  
 Summer time is set



## Choose Pico Operating Mode

The two Pico operating modes are RUN and STOP.

- RUN: Pico processes the circuit diagram.
- STOP: Create and modify the circuit diagram.

The alternating RUN/STOP menu shows either RUN or STOP as follows:

- STOP mode active: RUN is shown
- RUN mode active: STOP is shown

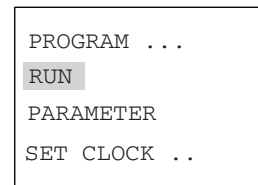

## Selectable Start-up Behavior

It is possible to select the operating mode to be activated when Pico is powered up. You can choose start-up in "RUN" mode or in "STOP" mode through the System Menu.







## Pico Circuit Diagram Elements

### Contacts

Contacts are used to modify the flow of current in the circuit diagram. Contacts in the circuit diagram are either make or break contacts. Make contacts are open when off (de-energized) and closed when on. Break contacts are closed when off and open when on.

Contact	Pico Representation
Make contact; Open when off	I, Q, M, A, C, T, P, D, S, :, R
Break contact; Closed when off	$\bar{I}$ , $\bar{Q}$ , $\bar{M}$ , $\bar{A}$ , $\bar{C}$ , $\bar{T}$ , $\bar{P}$ , $\bar{D}$ , $\bar{S}$ , $\bar{R}$

Pico works with different contacts, which can be used in any order in the contact fields of the circuit diagram.

Contact Type	Make Contact	Break Contact	1760-L12xxx	1760-L18xxx 1760-L20xxx
Controller Inputs	I	$\bar{I}$	I1 to I8	I1 to I12
0 signal			I13	I13
Expansion Status			–	I14 <sup>(3)</sup>
Short-circuit/overload			I16	I15 to I16
Soft Inputs - Keypad	P	$\bar{P}$	P1 to P4	P1 to P4
Controller Outputs	Q	$\bar{Q}$	Q1 to Q4	Q1 to Q8
Internal Marker Bits	M	$\bar{M}$	M1 to M16	M1 to M16
Internal Marker Bits	N	$\bar{N}$	N1 to N16	N1 to N16
Counters	C	$\bar{C}$	C1 to C16	C1 to C16
Timers	T	$\bar{T}$	T1 to T16	T1 to T16
Real Time Clock <sup>(1)</sup>			 <sub>1</sub> to  <sub>8</sub>	 <sub>1</sub> to  <sub>8</sub>
Analog Setpoint Compare <sup>(2)</sup>	A	$\bar{A}$	A1 to A16	A1 to A16
Text Display	D	$\bar{D}$	D1 to D16	D1 to D16
Expansion Outputs or Internal Marker Bits	S	$\bar{S}$	S1 to S8	S1 to S8
Jump to Label	:	–	:1 to :8	:1 to :8
Expansion Inputs	R	$\bar{R}$	–	R1 to R12
Expansion Overload Detection	R	$\bar{R}$	–	R15 and R16 <sup>(3)</sup>

Contact Type	Make Contact	Break Contact	1760-L12xxx	1760-L18xxx 1760-L20xxx
Operating Hours Counter	O	$\bar{O}$	O1 to O4	O1 to O4
Year Time Switch	Y	$\bar{Y}$	Y1 to Y8	Y1 to Y8
Master Reset	Z	$\bar{Z}$	Z1 to Z3	Z1 to Z3





(1) Not available on “-NC” models.

(2) This applies only to the 1760-LxxBWB-xx and 1760-L12DWD.

(3) This applies only to 1760-L18xxx-EX models. R15 and R16 are used for expansion overload detection for the transistor expansion module, 1760-IB12XOB8, as described on page 9-4.

## Relays

Pico has thirteen different types of relay for use in a circuit diagram.

Relay type	Pico Symbol	1760-L12xxx	1760-L18xxx 1760-L20xxx	Coil Function	Parameter
Controller Outputs	Q	Q1 to Q8	Q1 to Q8	X	–
Internal Marker Bits	M	M1 to M16	M1 to M16	X	–
Internal Marker Bits	N	N1 to N16	N1 to N16	X	–
Counters	C	C1 to C16	C1 to C16	X	X
Timers	T	T1 to T16	T1 to T16	X	X
Real Time Clock <sup>(1)</sup>		 <sub>1</sub> to  <sub>8</sub>	 <sub>1</sub> to  <sub>8</sub>	–	X
Operating Hours Counters	O	O1 to O4	O1 to O4	X	X
Analog Setpoint Compare <sup>(2)</sup>	A	A1 to A16	A1 to A16	–	X
Text Display	D	D1 to D16	D1 to D16	X	X
Jump to Label	:	:1 to :8	:1 to :8	X	–
Expansion Outputs or Internal Marker Bits	S	S1 to S8 (as marker)	S1 to S8	X	–
Year Time Switch	Y	Y1 to Y8	Y1 to Y8	–	X
Master Reset	Z	Z1 to Z3	Z1 to Z3	X	–

(1) Not available on “-NC” models.

(2) This applies only to the 1760-LxxBWB-xx and 1760-L12DWD.

The switching behavior of these relays is set using coil functions and parameters. The coil functions and parameters are listed with the description of each function relay type.



The options for setting output and marker relays are listed with the description of each coil function.

## Retentive Actual Values

With Pico 1760-L12BWB-xx, 1760-L12DWD, and 1760-L18xxx, it is possible to save the actual values of markers, timers and counters in the event of a power failure. The quantities and values that may be retained are found in the following table.

For further information see the *Pico Controller User Manual*, publication number 1760-UM001B-EN-P.

## Retentive Relays

Relay Type	Pico Symbol	1760-L12BWB-xx 1760-L12DWD	1760-L18xxx
Internal Marker Bits	M	4 (M13 to M16)	4 (M13 to M16)
Counters	C	1 (C8)	4 (C5, C6, C7, C8)
Timers	T	1 (T8)	2 (T7, T8)
Text Display	D	–	8 (D1 to D8)



**Basic Output Energize**

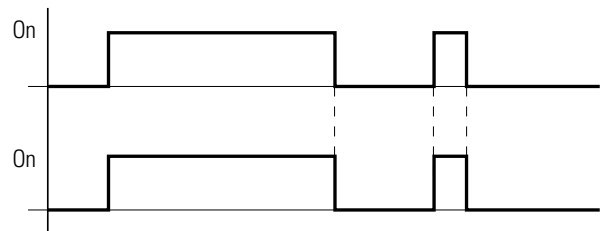
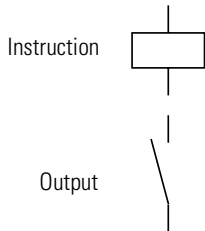

**Maintained/Flip-Flop Output**

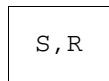
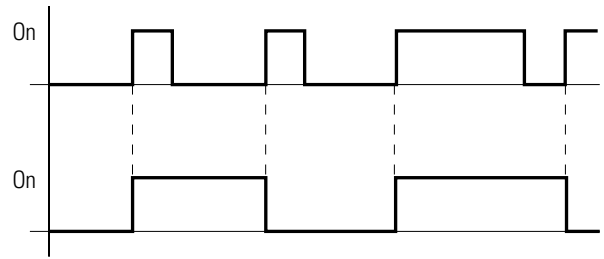
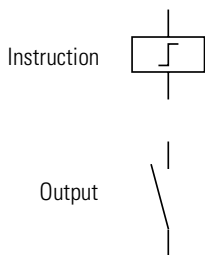

**Latching Output**

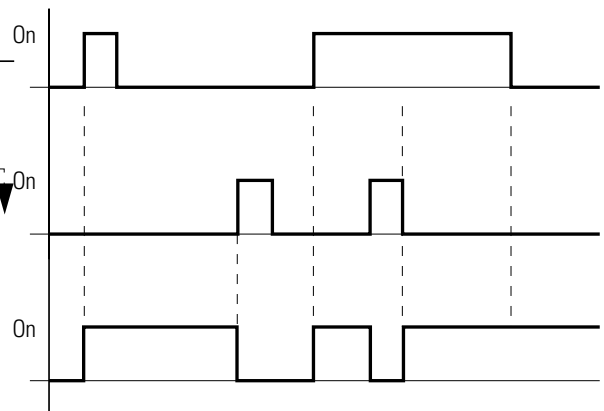
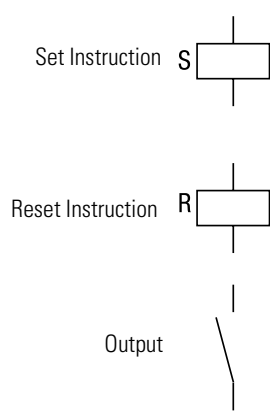

## Example: Creating a Circuit Interconnect Contacts and Relays Diagram

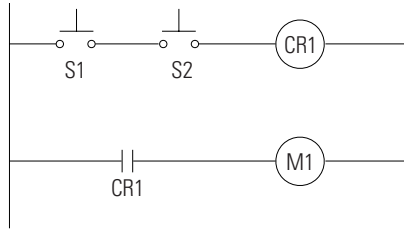

Pico circuit diagram

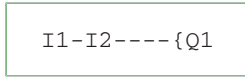

Connecting Pico

1. Connect S1 to Pico input terminal I1
2. Connect S2 to Pico input I2
3. Connect load M1 to Pico output Q1

## Draw Circuit in Circuit Diagram Menu

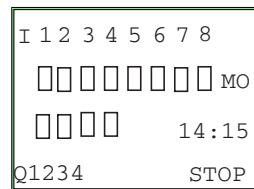

12-I/O Pico

or

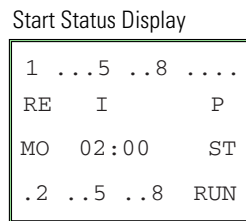

18-I/O Pico

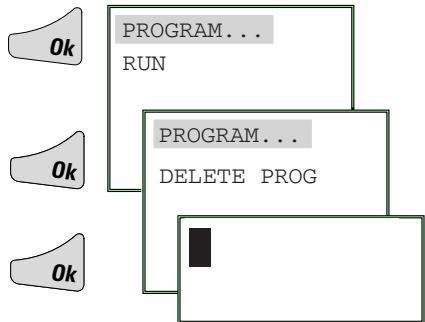

## Insert Contact "I1"

Circuit Diagram Display

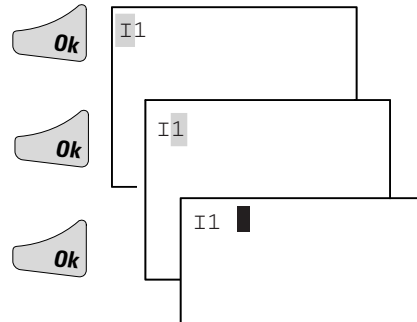
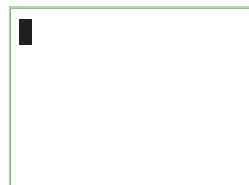

### Insert Contact "I2"

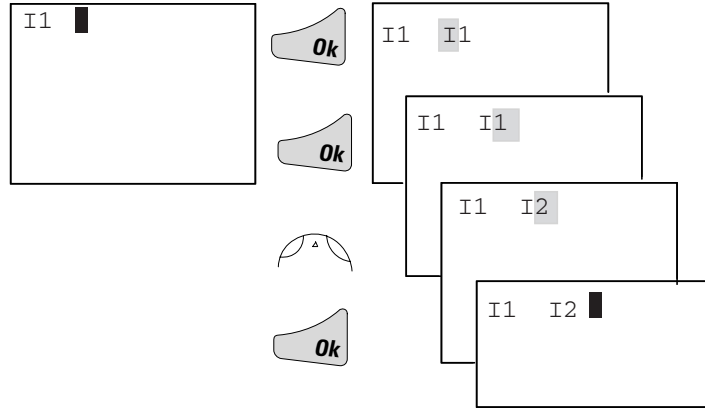

### Draw Connection Between Contact and Relay Coil

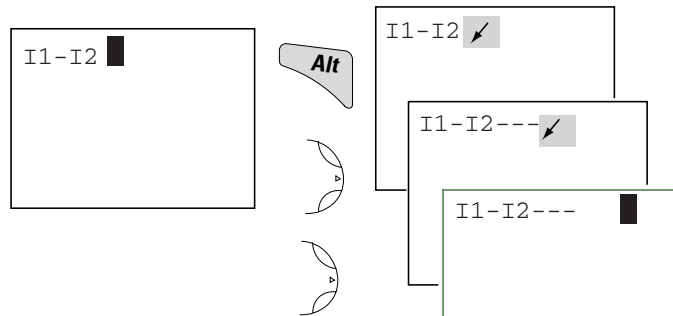

### Choose Relay Coil "Q1"

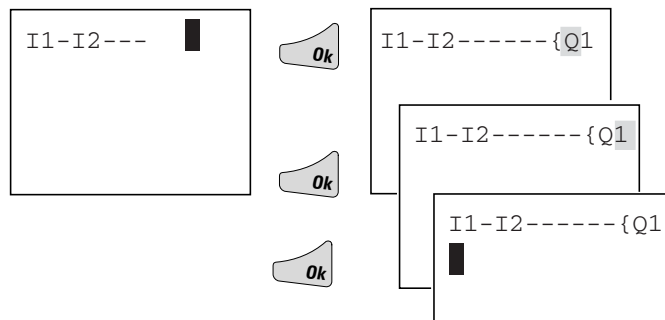

### Change Operating Mode

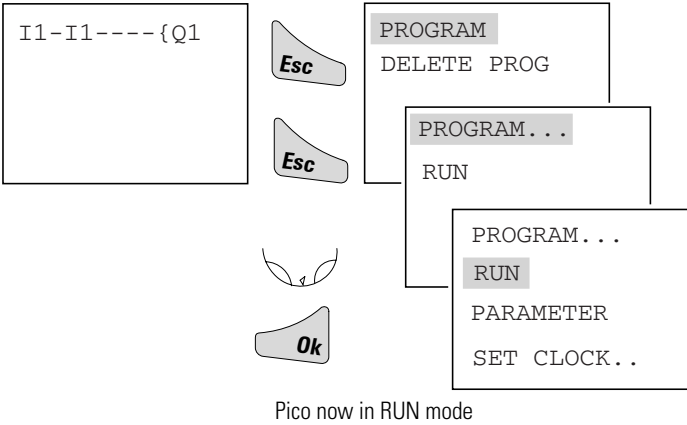

### Test Circuit Diagram

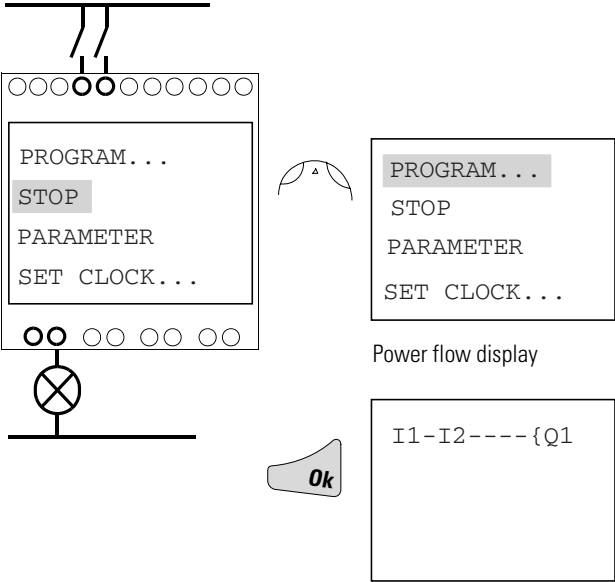

### Operate Switch "S1" and "S2"

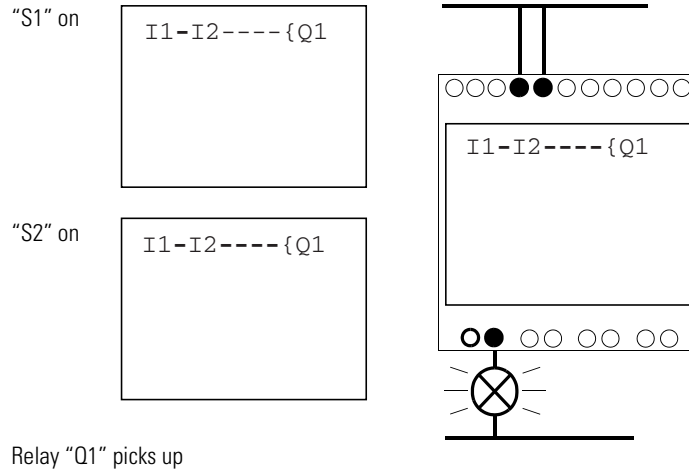

### Return to Status Display with ESC

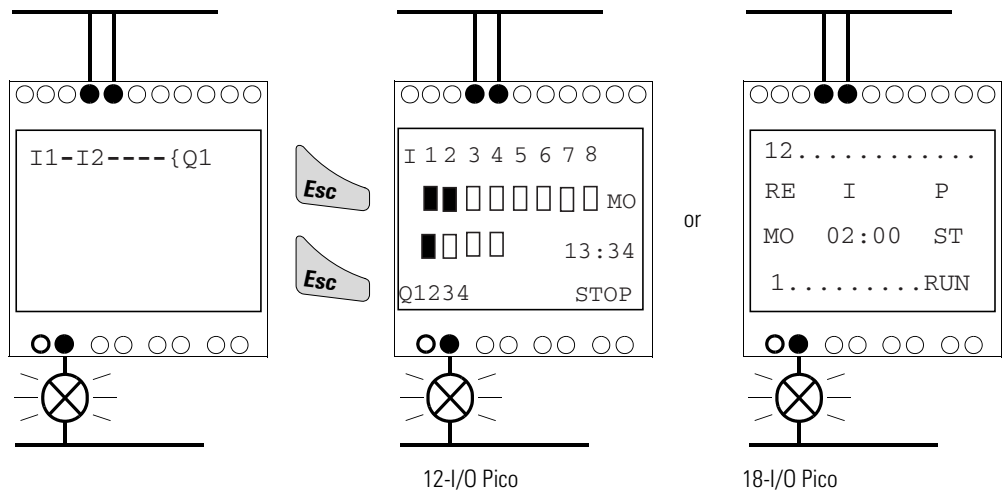

In the next example, a timing relay will be added to the circuit.

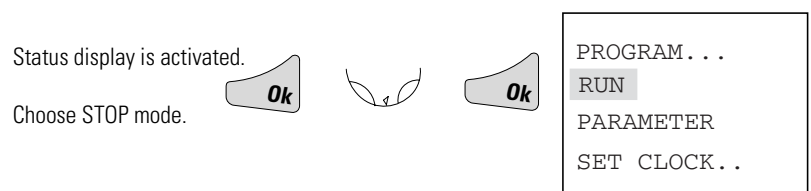

# Function Relay Types

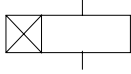
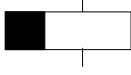
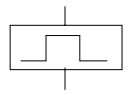
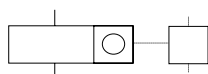
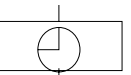
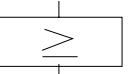
Circuit Diagram Symbol	Function Relay Type
	Timing relay with on-delay, with and without random switching
	Timing relay with off-delay, with and without random switching
	Timing relay, single pulse Timing relay, flashing
	Counter relay, up/down counter
	Time switch, weekday/time (only in Pico models with clock)
	Analog comparator relay (only in Pico models with 24V dc)

## Timing Relay

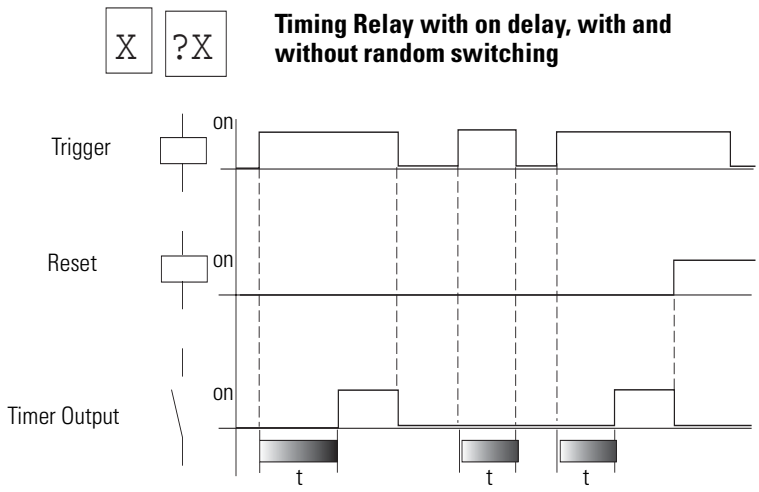

 **Timing Relay with Off-Delay, with and without Random Switching**

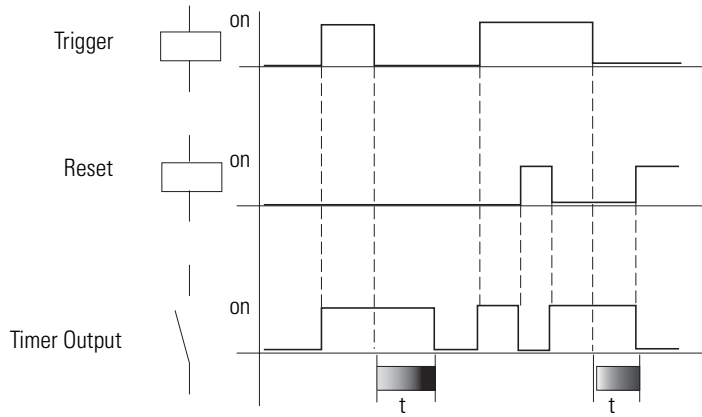

With random switching, the relay contact switches randomly at any time up to the specified time value (shown shaded in figure).

 **Timing Relay, Single Pulse**

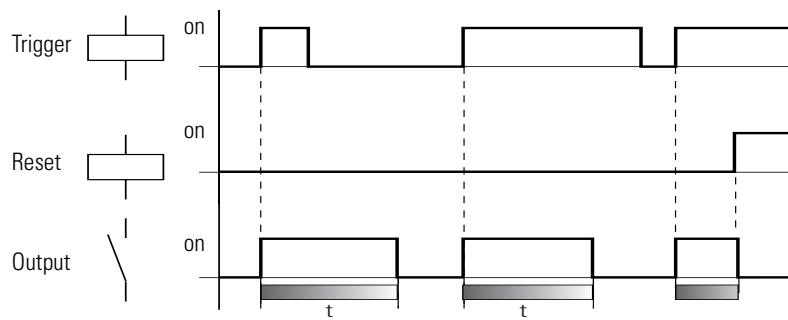





**Timing Relay, Flashing**

Flash Frequency = 1/2 x setpoint

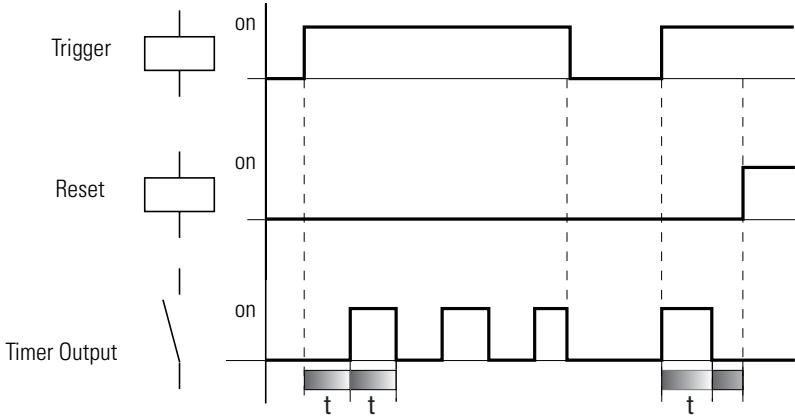

**Parameter Display for Timing Relays**

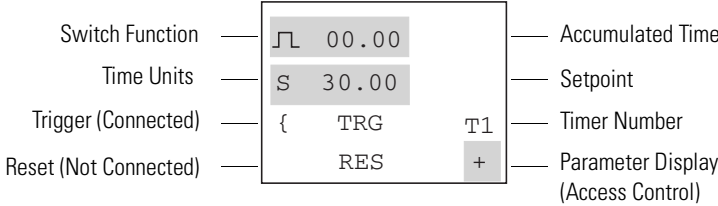

## Counter Relay

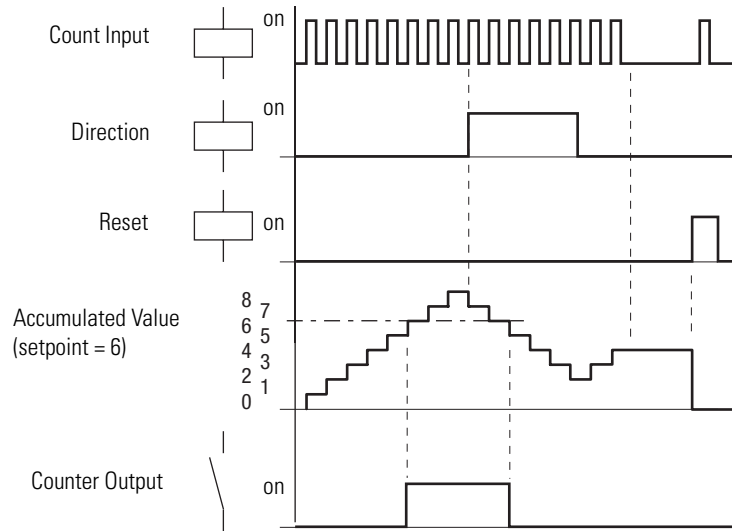

## Parameter Display for Counter Relays

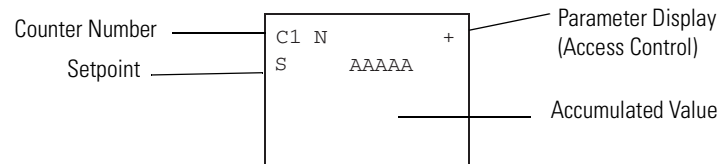

### Real Time Switch

**Example:** Real Time Switch 1 switches on Monday through Friday between 6:30 and 9:00 and again between 17:00 and 22:30 (5:00 pm and 10:30 pm).

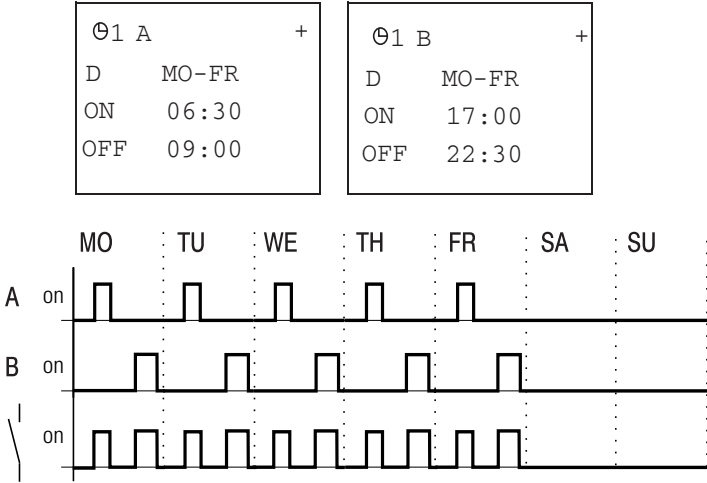

### Parameter Display for Real Time Switches

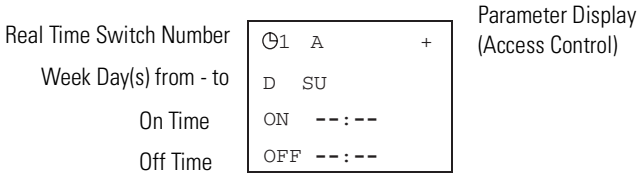

## Analog Comparator

Available functions:

- $I7 \geq I8, I7 \leq I8$
- $I7 \geq \text{Setpoint}, I7 \leq \text{Setpoint}$
- $I8 \geq \text{Setpoint}, I8 \leq \text{Setpoint}$

The analog comparator can compare voltages from 0V to 10V (setpoints “0.0” to “10.0”).

**TIP**

Analog signals of sensors typically fluctuate by several millivolts. For stable switching the setpoints should differ by at least 0.2V (switching hysteresis). Do not use any relay with output energize or impulse relay coil functions.

## Parameter Displays for Analog Comparators

Compare inputs I7 and I8.

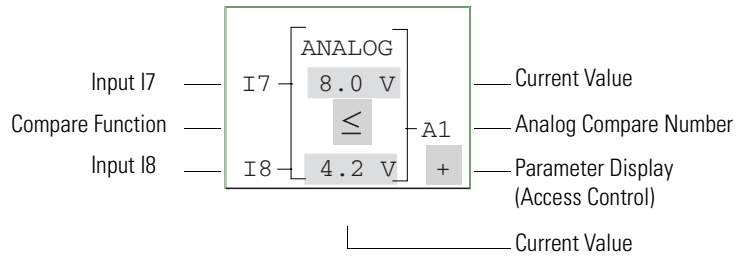

Compare input “I7” to a setpoint.

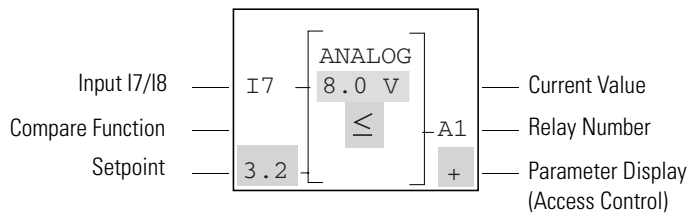

## Text Display

The Text Display is used to display eight freely definable messages on the Pico screen. Each text block displays up to 48 characters from the Pico display character set (ASCII + Pico special characters). If the Text Display is enabled, the text entered via PicoSoft is displayed. If several Text Displays are enabled, the next screen is displayed every 4 seconds. When Text Display D1 is enabled it stays displayed (fault indication).

Press *Ok* to switch to the menus at any time.

Current values or parameters of function relays can be displayed in lines 2 and 3.

Examples:

Fault Signals

```
CAUTION!  
PUMP 1  
MOTOR  
MALFUNCTION
```

Time with Text Display

```
THE TIME  
IS  
14:42
```

Display Counter Value

```
QUANTITY  
ACTV 0042  
PCS  
SETP0100
```

Display Current Value and Parameter of Timing Relay

```
TIME RELAY 1  
SETP99.00 S  
ACTV 42.00 S
```

## Example: Use a Function Relay

### Conventional Circuit

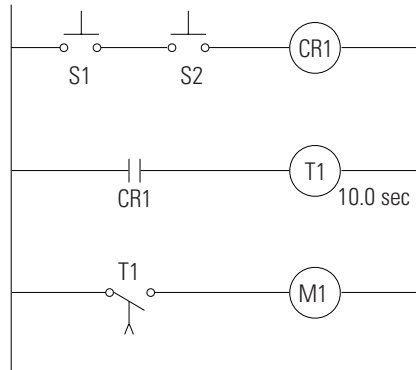

Pico switches M1 with 10 seconds delay.

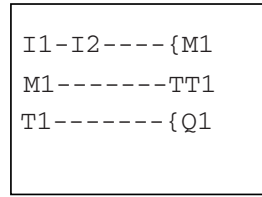

Pico Circuit Diagram

### Select an Internal Marker Relay

Start Circuit from first example

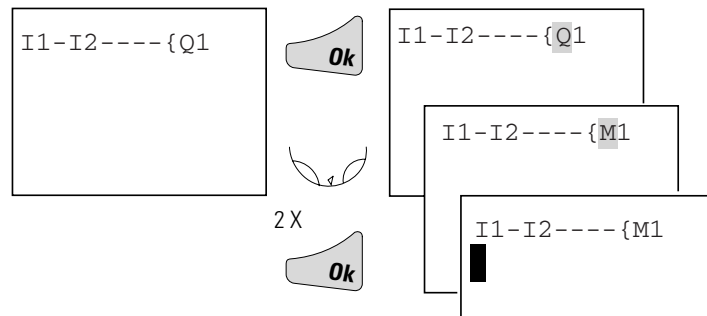

### Select Marker Contact and Connect to New Output Relay

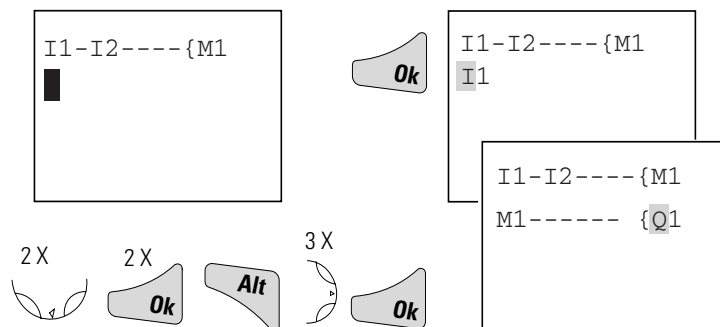

### Select Trigger Relay for Time

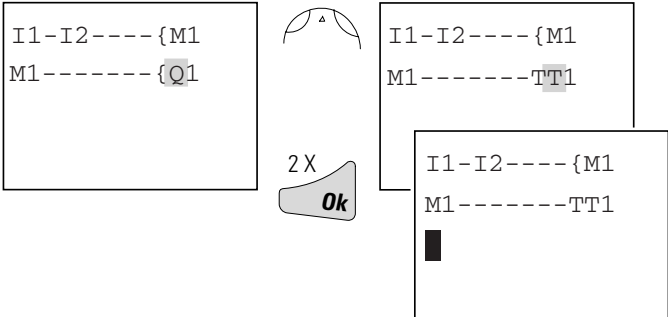

### Insert Timing Relay Contact

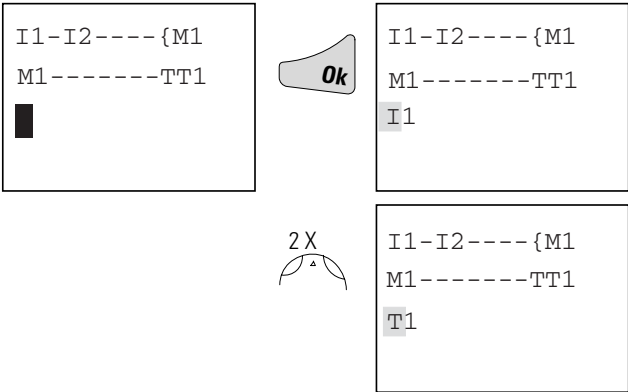

### Select Parameter Access

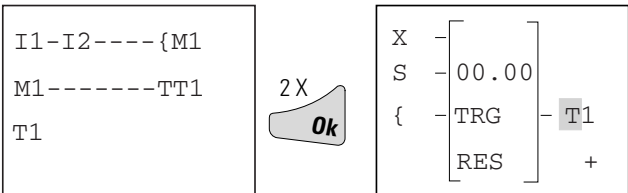

### Set "10 Seconds"

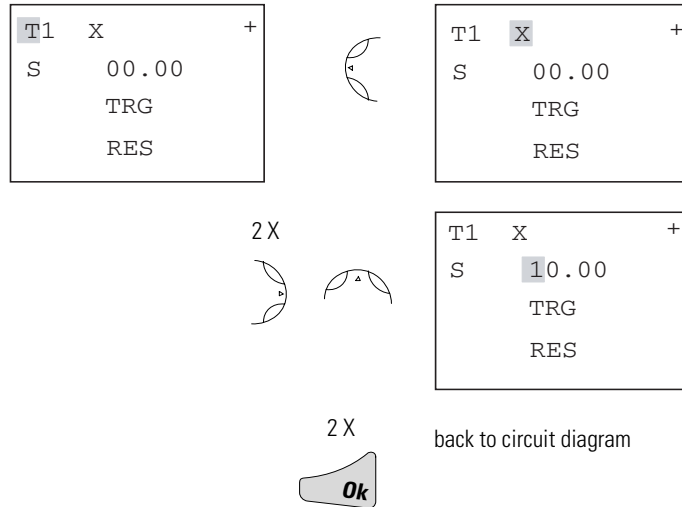

### Connect Timing Relay Contact to New Output Relay

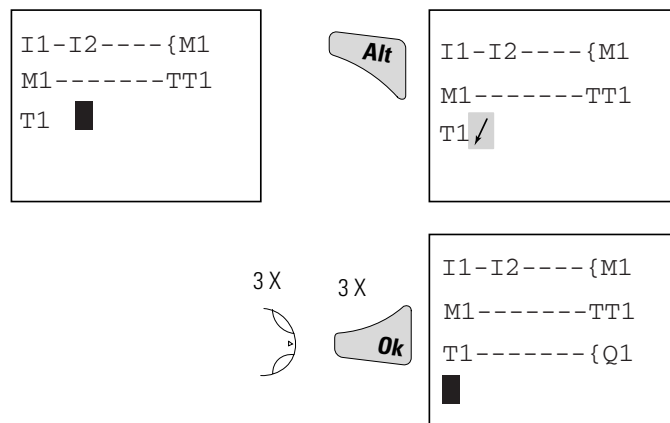

Change Pico to RUN to test the program. Test the circuit as shown for the first example. To display and access the parameters for the timing relay and change the time value in RUN mode, position the cursor in the circuit diagram on the "T" of "T1" and press *Ok*.



# Basic Circuits

## Significance of Logic Values

Value	Function
"0"	Make contact open, break contact closed, relay coil not energized
"1"	Make contact closed, break contact open, relay coil energized

### Negation (NOR)

I1	Q1
1	0
0	1

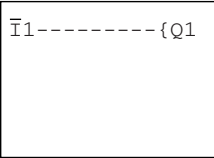

### Permanent Contact (Unconditional Rung)

---	Q1
1	1

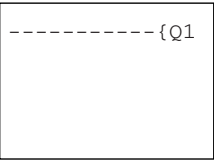

### Flip-Flop Output

I1	State Q1	Q1
0	0	0
0 to 1	0	1
0	1	1
0 to 1	1	0

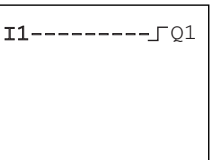

*Series Connection (AND)*

I1	I2	I3	Q1	Q2
0	0	0	0	1
1	0	0	0	0
0	1	0	0	0
1	1	0	0	0
0	0	1	0	0
1	0	1	0	0
0	1	1	0	0
1	1	1	1	0

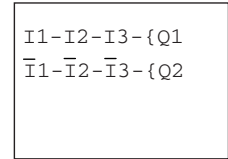

*Parallel Connection (OR)*

I1	I2	I3	Q1	Q2
0	0	0	0	1
1	0	0	1	1
0	1	0	1	1
1	1	0	1	1
0	0	1	1	1
1	0	1	1	1
0	1	1	1	1
1	1	1	1	0

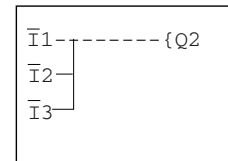
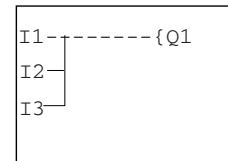

*Exclusive OR Circuit (XOR)*

I1	I2	Q1
0	0	0
1	0	1
0	1	1
1	1	0

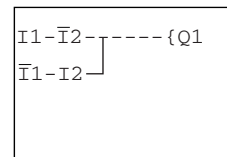

*Motor Start/Stop Circuit*

I1	I2	Contact Q1	Coil Q1
0	0	0	0
1	0	1	1
0	0	1	1
0	1	0	0
1	1	0	0

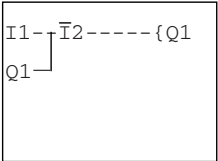

Alternatively:

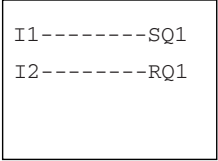



## Pico Interface Socket

The Pico interface socket, which is beneath a protective cap, accepts the optional Pico memory module, or connects Pico to a PC using the optional PC interface cable and the PicoSoft software. This allows you to copy the circuit diagrams to and from the PC and/or memory module.

### Memory Module

Memory modules are available as an optional accessory. Each memory module can store a single Pico circuit diagram. Information stored on the memory module is non-volatile (the information is not lost when the power is turned off). The memory module can be used to make a backup copy of a program and/or to transfer it to another Pico controller.

Each memory module can hold one Pico program, up to 32K. ■

Each memory module stores:

- the circuit diagram
- all parameter settings of the circuit diagram
- system settings

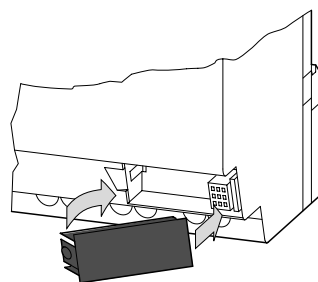

1760-MM1 for all 1760-L12xxx controllers

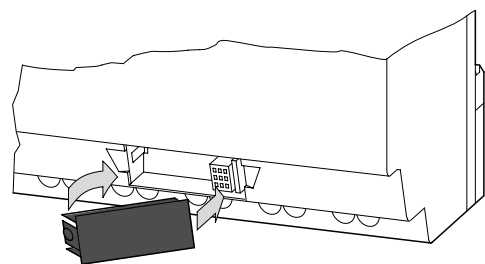

1760-MM2 for the 1760-L18xxx controllers

<b>ATTENTION</b>	<b>ELECTRICAL SHOCK HAZARD</b>
	<p>The memory module and PC-cable socket are at the potential of L2. There is a danger of electric shock if L2 is not grounded. Do not make contact with electrical components under the socket cover.</p>

### Load or Store the Circuit Diagram

You can only transfer the program from Pico to the memory module or vice versa in the STOP mode.

DEVICE - CARD: Transfer circuit diagram and parameter settings from Pico to the memory module.

DEVICE -> CARD
CARD -> DEVICE
DELETE CARD

CARD - DEVICE: Transfer circuit diagram and parameter settings from the memory module to Pico.

DELETE CARD: Delete the contents of the memory module.

### Available Memory Modules

The following memory modules are available as Pico accessories.

Pico Controller	Memory Module
1760-L12xxx	1760-MM1 (Series A only)
1760-L18xxx	1760-MM2 (Series A only)
Series B Pico Controllers	1760-MM2B

Programs including all relevant data can be transferred from the 1760-MM2B memory module to the Series B Pico Controllers. The existing 1760-MM1 and 1760-MM2 memory modules are Read-Only when used with Series B Pico Controllers. The 1760-MM2B memory module will not work with Series A Pico Controllers.

## PicoSoft

PicoSoft is an optional PC program that creates, stores, and manages Pico circuit diagrams. It transfers the circuit diagrams from the PC to Pico or vice versa using a special PC interface cable.

### ATTENTION



The PC interface cable is catalog number 1760-CBL-PM02 and is available as an accessory item. Only use the Pico interface cable. Do not attempt to make your own cable as this can cause damage to the unit or present a shock hazard.

The PicoSoft software also includes extensive on-line Help.

To use the on-line Help, start PicoSoft and choose Contents in the Help menu. Context sensitive help is also available. Choose a menu item with the mouse and press F1 while keeping the mouse button pressed.

## Software Compatibility

If you are using programming software to program the Pico controller, be sure that you are using the correct software version.

### IMPORTANT

PicoSoft version 6.1 or higher must be used to for the Series B Pico controller. Earlier versions of PicoSoft can only be used with Series A Pico controllers.

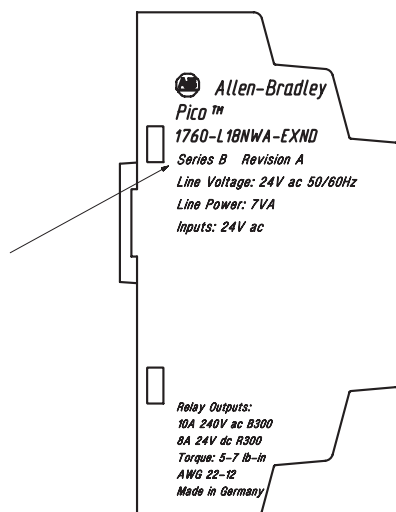

### *Find the Series Letter*

The Series letter is printed on the side of the housing as shown.

### *Download the Software*

You can download a free copy of PicoSoft version 6.1 from our web site. Go to <http://www.ab.com/picosoft6>.

For PicoSoft Pro, please contact your Allen-Bradley Distributor or Rockwell Automation representative.





## Specifications

### Physical Specifications

Specification	1760-L12xxx	1760-L18xxx, 1760-L20xx 1760-IA12XOW6I, 1760-IA12XOW4I 1760-IB12XOB8 1760-IB12XOB8	1760-OW2
Weight	200g (7 oz)	300g (10.6 oz)	70g (0.154 lb)
Ambient temperature, (operation)	-25°C to + 55°C (-18°F to 131°F)		
Storage Temperature	-40°C to +70°C (-40°F to +158°F)		
Operating Humidity	5 to 95%, non-condensing		
Emitted interference, interference immunity	EN 55011, EN 55022, Class B		
Standards and regulations Approvals	EN 50178 UL, CSA, CE, C-Tick		

### Product Selection Table      Controllers

Catalog Number	Inputs	Outputs	Line Power	Real Time Clock	Display and Keypad	Analog
1760-L12AWA	8 (120/240V ac)	4 (relay)	100 - 240V ac	Yes	Yes	No
1760-L12AWA-NC <sup>(1)</sup>				No	Yes	
1760-L12AWA-ND <sup>(2)</sup>				Yes	No	
1760-L18AWA	12 (120/240V ac)	6 (relay)		Yes	Yes	
1760-L18AWA-EX <sup>(3)</sup>				Yes	Yes	
1760-L18AWA-EXND <sup>(2)(3)</sup>				Yes	No	

Catalog Number	Inputs	Outputs	Line Power	Real Time Clock	Display and Keypad	Analog	
1760-L12BWB	8 (24V dc)	4 (relay)	24V dc	Yes	Yes	2 (0 to 10V dc)	
1760-L12BWB-NC <sup>(1)</sup>				No	Yes		
1760-L12BWB-ND <sup>(2)</sup>				Yes	No		
1760-L12BBB		4 (MOSFET)	Yes	Yes	2 (0 to 10V dc)		
1760-L12BBB-ND	Yes		No				
1760-L12NWA	8 (24V ac)	4 (relay)	24V ac	Yes	Yes	2 (0 to 10V dc)	
1760-L12NWA-ND				Yes	No		
1760-L12DWD	8 (12V dc)		12V dc	Yes	Yes		
1760-L12DWD-ND				Yes	No		
1760-L18BWB-EX <sup>(3)</sup>	12 (24V dc)	6 (relay)	24V dc	Yes	Yes		2 (0 to 10V dc)
1760-L18BWB-EXND <sup>(2)(3)</sup>		6 (relay)		Yes	No		
1760-L20BBB-EX <sup>(3)</sup>		8 (MOSFET)		Yes	Yes	4 (0 to 10V dc)	
1760-L20BBB-EXND <sup>(2)(3)</sup>		8 (MOSFET)		Yes	No		
1760-L18DWD-EX <sup>(3)</sup>	12 (12V dc)	6 (relay)	12V dc	Yes	Yes	4 (0 to 10V dc)	
1760-L18DWD-EXND <sup>(2)(3)</sup>		6 (relay)	12V dc	Yes	No		
1760-L18NWA-EX <sup>(3)</sup>	12 (24V ac)	6 (relay)	24V ac	Yes	Yes	4 (0 to 10V dc)	
1760-L18NWA-EXND <sup>(2)(3)</sup>	12 (24V ac)	6 (relay)		Yes	No		

(1) NC = no real time clock

(2) ND = no display

(3) EX = suitable for use with expansion modules

## Expansion Modules

Catalog Number	Inputs	Outputs	Line Power
1760-IA12XOW6I	12 (100 - 240V ac)	6 (relay)	100 - 240V ac
1760-IA12XOW4IF	12 (100 - 240V ac)	4 (relay)	100 - 240V ac
1760-IB12XOW6I	12 (24V dc)	6 (relay)	24V dc
1760-IB12XOB8	12 (24V dc)	8 (transistor)	24V dc
1760-OW2	-	2 (relay)	24V dc

## Accessories

Catalog Number	Description
1760-MM1	Memory Module for 12 I/O Pico Controller
1760-MM2	Memory Module for 18 I/O Pico Controller
1760-MM2B	Memory Module for Pico Series B Controllers
1760-CBL-PM02	Programming Cable for Pico Controller
1760-RPLCONN	Expansion Module Connector - included with expansion module. Catalog number listed is replacement part.
1760-SIM	Input Simulator for 12 I/O 24V dc Pico Controller
1760-PICOSOFT	Configuration Software for Pico Controllers.
D1760GR001BENP	Pico Controllers Getting Results Manual, publication number 1760-GR001B-EN-P
D1760UM001BENP	Pico Controllers User Manual, publication number 1760-UM001B-EN-P

## Dimensions

### Pico 1760-L12xxx

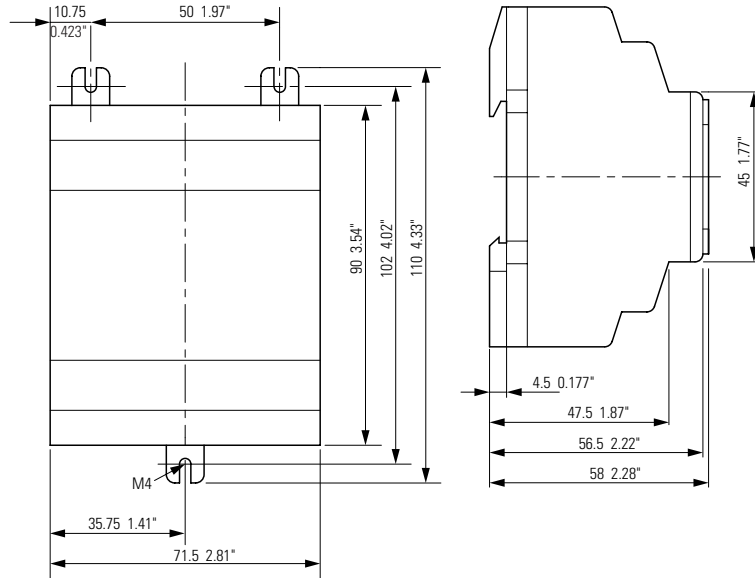

### Pico 1760-L18xxx, 1760-L20xxx and Expansion Modules

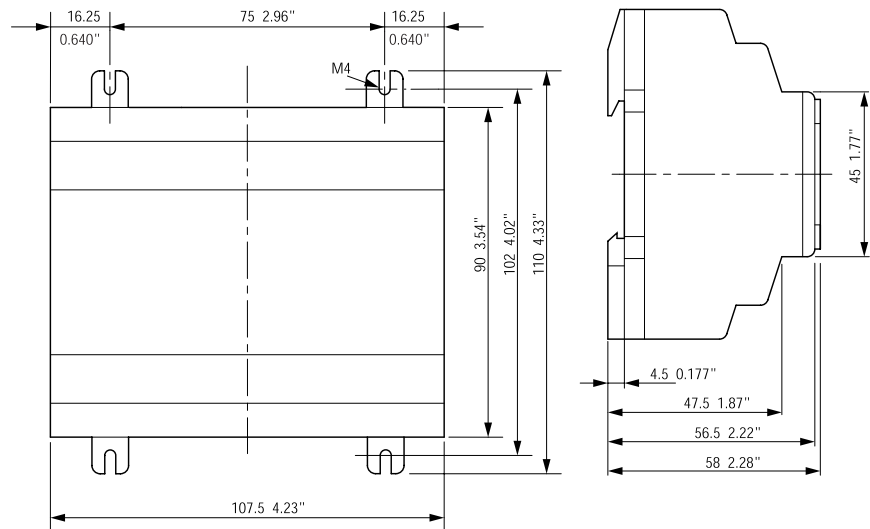

## Pico 1760-OW2 Expansion Module

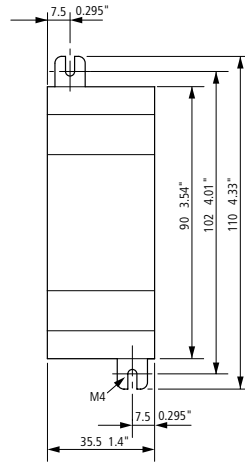

## Dimensions of the 1760-RM... Remote Processor modules

176-RM...

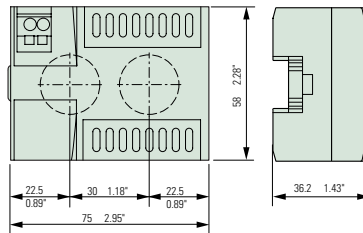

1760-DU... and 176-RM...

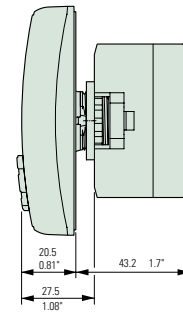



**A**

- accessories** A-3
- Allen-Bradley**
  - contacting for assistance Preface-iii
  - support Preface-iii
- Analog comparator** 2-18

**B**

- Basic circuit**
  - Exclusive OR circuit (XOR) 2-24
  - Flip-flop output 2-23
  - Impulse relay 2-23
  - Motor start/stop circuit 2-25
  - Negation (NOR) 2-23
  - Permanent contact 2-23
  - Series connection (AND) 2-24
- Break contact** 2-5
- Buttons** 1-10
  - Use in circuit diagrams 2-1

**C**

- Cable** 3-3
- Change operating mode** 2-4
- Circuit diagram**
  - Access relay parameters 2-21
  - Choosing relay type 2-10
  - Displaying 2-9
  - Example 2-9, 2-20
  - Inserting contacts 2-9
  - Loading 3-2
  - Select marker relay 2-20
  - Storing 3-2
  - Symbols 1-14
  - Testing 2-11
  - Using a function relay 2-20
  - Using buttons in 2-1
- Circuit diagram elements** 2-5
- Coil function** 2-8
- common techniques used in this manual**
  - Preface-ii
- contacting Allen-Bradley for assistance**
  - Preface-iii
- Contactor function** 2-8
- Contacts**
  - Overview 2-5
- Counter relay** 2-16
  - Parameter display 2-16
- Cursor display** 1-13

**D****dimensions**

- 1760-L12 A-4
- 1760-L18 A-4
- 1760-L20 A-4
- 1760-OW2 A-5
- 1760-RM A-5
- expansion modules A-4

**E**

- Example**
  - Basic circuits 2-23
  - Circuit diagram 2-9
  - Contacts and relays 2-9
- Example of function relay** 2-20

**F**

- Function relays**
  - Analog comparator 2-18
  - Counter relay 2-16
  - Overview 2-13
  - Text display 2-19
  - Time switch 2-17
  - Timing relay 2-13

**K**

- Keypad** 1-10

**L**

- Logic tables** 2-23

**M**

- Make contact** 2-5
- manuals, related** Preface-ii
- Memory Module (optional)** 3-1
- Menu guidance** 1-11
- Menu structure** 1-15
- Mounting** 1-3

**O**

- Operating buttons** 1-10

**P**

- Parameter display**
  - Analog comparator 2-18
  - Counter relay 2-16
  - For timing relays 2-15
  - Time switch 2-17

**physical specifications** A-1  
**Overview of Pico** 1-2  
**PicoSoft** 3-3  
**Programming cable** 3-3  
**publications, related** Preface-ii  
**Purpose of this Manual** Preface-ii

## R

**related publications** Preface-ii  
**Relay types**  
    Overview 2-6

## S

**selection table**  
    controllers A-1  
**selections table**  
    expansion modules A-3  
**Setting the time** 2-3  
**Setting week day** 2-3  
**Software** 3-3  
**specifications**  
    physical A-1  
**Startup behavior** 2-4  
**Status display** 1-12  
**Summer time** 2-4

**Symbols in circuit diagram** 1-14  
**System menu** 1-18

## T

**Terminals, inputs/outputs** 1-4  
**Text display** 2-19  
**Time switch** 2-17  
    Parameter display 2-17  
**Timing relays** 2-13  
    Parameter display 2-15  
**troubleshooting**  
    contacting Allen-Bradley for assistance  
    Preface-iii

## W

**Winter time** 2-4  
**Wiring diagrams**  
    1760-L12AWA-NC, 1760-L12AWA, and  
        1760-L12AWA-ND 1-4  
    1760-L12AWA-xx and 1760-L12BWB-xx  
        1-5  
    1760-L12BWB and 1760-L12BWB-NC  
        1-4  
    1760-L18AWA 1-9  
    1760-OW2 1-9





# Rockwell Automation Support

Rockwell Automation provides technical information on the web to assist you in using our products. At <http://support.rockwellautomation.com>, you can find technical manuals, a knowledge base of FAQs, technical and application notes, sample code and links to software service packs, and a MySupport feature that you can customize to make the best use of these tools.

For an additional level of technical phone support for installation, configuration and troubleshooting, we offer TechConnect Support programs. For more information, contact your local distributor or Rockwell Automation representative, or visit <http://support.rockwellautomation.com>.

## Installation Assistance

If you experience a problem with a hardware module within the first 24 hours of installation, please review the information that's contained in this manual. You can also contact a special Customer Support number for initial help in getting your module up and running:

United States	1.440.646.3223 Monday – Friday, 8am – 5pm EST
Outside United States	Please contact your local Rockwell Automation representative for any technical support issues.

## New Product Satisfaction Return

Rockwell tests all of our products to ensure that they are fully operational when shipped from the manufacturing facility. However, if your product is not functioning and needs to be returned:

United States	Contact your distributor. You must provide a Customer Support case number (see phone number above to obtain one) to your distributor in order to complete the return process.
Outside United States	Please contact your local Rockwell Automation representative for return procedure.

[www.rockwellautomation.com](http://www.rockwellautomation.com)

### Corporate Headquarters

Rockwell Automation, 777 East Wisconsin Avenue, Suite 1400, Milwaukee, WI, 53202-5302 USA, Tel: (1) 414.212.5200, Fax: (1) 414.212.5201

### Headquarters for Allen-Bradley Products, Rockwell Software Products and Global Manufacturing Solutions

Americas: Rockwell Automation, 1201 South Second Street, Milwaukee, WI 53204-2496 USA, Tel: (1) 414.382.2000, Fax: (1) 414.382.4444

Europe: Rockwell Automation SA/NV, Vorstlaan/Boulevard du Souverain 36-BP 3A/B, 1170 Brussels, Belgium, Tel: (32) 2 663 0600, Fax: (32) 2 663 0640

Asia Pacific: Rockwell Automation, 27/F Citicorp Centre, 18 Whitfield Road, Causeway Bay, Hong Kong, Tel: (852) 2887 4788, Fax: (852) 2508 1846

### Headquarters for Dodge and Reliance Electric Products

Americas: Rockwell Automation, 6040 Ponders Court, Greenville, SC 29615-4617 USA, Tel: (1) 864.297.4800, Fax: (1) 864.281.2433

Europe: Rockwell Automation, Brühlstraße 22, D-74834 Elztal-Dallau, Germany, Tel: (49) 6261 9410, Fax: (49) 6261 17741

Asia Pacific: Rockwell Automation, 55 Newton Road, #11-01/02 Revenue House, Singapore 307987, Tel: (65) 351 6723, Fax: (65) 355 1733