



DC (24V) Isolated Output Module (Catalog Number 1771-OQ16 Series C)

To the Installer

This document provides information on:

For information on:	See page
↓ Important User Information	1
↓ Preinstallation Considerations	4
↓ Calculate Power Requirements	4
↓ Determine Module Placement in the Chassis	4
↓ Key the Backplane Connector	5
↓ Install the Module and Field Wiring Arm	6
↓ Connect Wiring to the Output Module	7
↓ Replacing the Fuse	11

For this reference information	See page
➡ Interpreting the Status Indicators	10
➡ Hazardous Location Approval	12
➡ Specifications	13

Important User Information

Because of the variety of uses for the products described in this publication, those responsible for the application and use of these products must satisfy themselves that all necessary steps have been taken to assure that each application and use meets all performance and safety requirements, including any applicable laws, regulations, codes and standards. In no event will Rockwell Automation be responsible or liable for indirect or consequential damage resulting from the use or application of these products.

Any illustrations, charts, sample programs, and layout examples shown in this publication are intended solely for purposes of example. Since there are many variables and requirements associated with any particular installation, Rockwell Automation does not assume responsibility or liability (to include intellectual property liability) for actual use based upon the examples shown in this publication.

Allen–Bradley publication SGI–1.1, Safety Guidelines for Application, Installation, and Maintenance of Solid–State Control (available from your local Rockwell Automation office), describes some important differences between solid–state equipment and electromechanical devices that should be taken into consideration when applying products such as those described in this publication.

Reproduction of the contents of this copyrighted publication, in whole or part, without written permission of Rockwell Automation, is prohibited.

Throughout this publication, notes may be used to make you aware of safety considerations. The following annotations and their accompanying statements help you to identify a potential hazard, avoid a potential hazard, and recognize the consequences of a potential hazard.

WARNING

Identifies information about practices or circumstances that can cause an explosion in a hazardous environment, which may lead to personal injury or death, property damage, or economic loss.

ATTENTION

Identifies information about practices or circumstances that may lead to personal injury or death, property damage, or economic loss.

IMPORTANT

Identifies information that is critical for successful application and understanding of the product.

ATTENTION**Environment and Enclosure**

This equipment is intended for use in a Pollution Degree 2 industrial environment, in overvoltage Category II applications (as defined in IEC publication 60664–1), at altitudes up to 2000 meters without derating.

This equipment is considered Group 1, Class A industrial equipment according to IEC/CISPR Publication 11. Without appropriate precautions, there may be potential difficulties ensuring electromagnetic compatibility in other environments due to conducted as well as radiated disturbance.

This equipment is supplied as “open type” equipment. It must be mounted within an enclosure that is suitably designed for those specific environmental conditions that will be present, and appropriately designed to prevent personal injury resulting from accessibility to live parts. The interior of the enclosure must be accessible only by the use of a tool. Subsequent sections of this publication may contain additional information regarding specific enclosure type ratings that are required to comply with certain product safety certifications.

See NEMA Standards publication 250 and IEC publication 60529, as applicable, for explanations of the degrees of protection provided by different types of enclosures. Also, see the appropriate sections in this publication, as well as the Allen–Bradley publication 1770–4.1, (“Industrial Automation Wiring and Grounding Guidelines”), for additional installation requirements pertaining to this equipment.

ATTENTION**Preventing Electrostatic Discharge**

This equipment is sensitive to electrostatic discharge, which can cause internal damage and affect normal operation. Follow these guidelines when you handle this equipment:

- Touch a grounded object to discharge potential static.
 - Wear an approved grounding wriststrap.
 - Do not touch connectors or pins on component boards.
 - Do not touch circuit components inside the equipment.
 - If available, use a static-safe workstation.
 - When not in use, keep modules in appropriate static-safe packaging.
-

Pre-installation Considerations

This module is designed to operate with dc relays and other dc output devices.

This module can be used in all 1771 I/O chassis except 1771-A1, A2 and A4 chassis. It can also be used in the 1771-AM1 and -AM2 chassis.

This module is **not** compatible with the 1771-AL local I/O adapter.

Calculate Power Requirements

The isolated output module is powered by the power supply connected to the I/O chassis backplane. The module requires a maximum current of 400mA from the +5V dc output of this supply. Total the current requirements of this module with the other modules in the I/O chassis to avoid overloading the supply or the I/O chassis backplane.

Determine Module Placement in the Chassis

Group your modules to minimize adverse effects from radiated electrical noise and/or heat. We recommend the following:

- Group analog input and low voltage dc modules away from ac modules or high voltage dc modules to minimize electrical noise interface.
- Place analog input modules and other I/O modules sensitive to heat away from slot power supplies to minimize adverse heat effects.

Key the Backplane Connector

ATTENTION



A module inserted into a wrong slot could be damaged by improper voltages connected through the wiring arm. Use keying bands to prevent damage to the module.

Place your module in any slot in the chassis except the leftmost slot, which is reserved for processors or adapters.

ATTENTION



Observe the following precautions when inserting or removing keys:

- insert or remove keys with your fingers
- make sure that key placement is correct

Incorrect keying or the use of a tool can result in damage to the backplane connector and possible system faults.

Position the keying bands in the backplane connectors to correspond to the key slots on the module.

Place the keying bands:
 - between 22 and 24
 - between 32 and 34

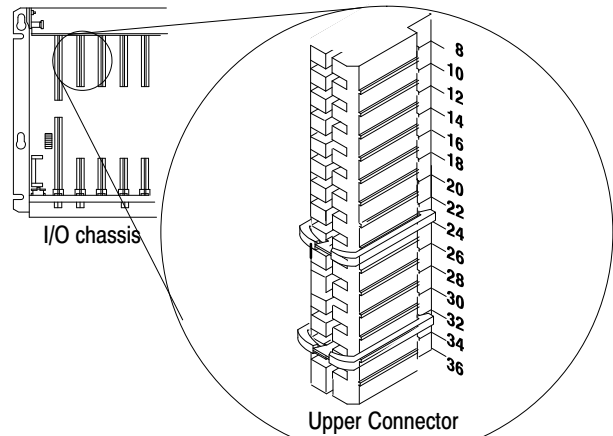

You can change the position of these bands if subsequent system design and rewiring makes insertion of a different type of module necessary.

11022-I

Install the Module and Field Wiring Arm

WARNING



When you insert or remove the module while backplane power is on, or you connect or disconnect the wiring arm with field power applied, an electrical arc can occur. This could cause an explosion in hazardous location installations. Be sure power is removed or the area is nonhazardous before proceeding.

ATTENTION



Remove power from the 1771 I/O chassis backplane and field wiring arm before removing or installing an I/O module.

- Failure to remove power from the backplane or wiring arm could cause module damage, degradation of performance, or injury.
- Failure to remove power from the backplane could cause injury or equipment damage due to possible unexpected operation.

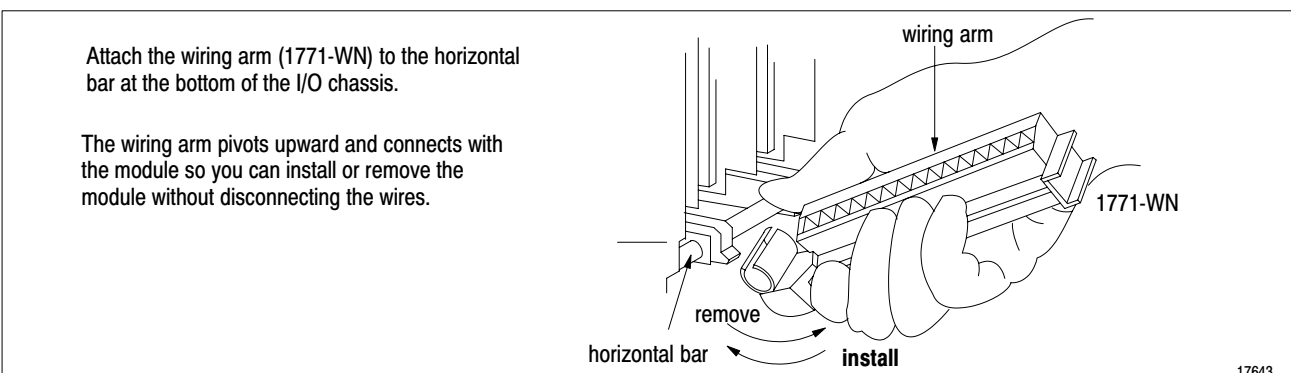
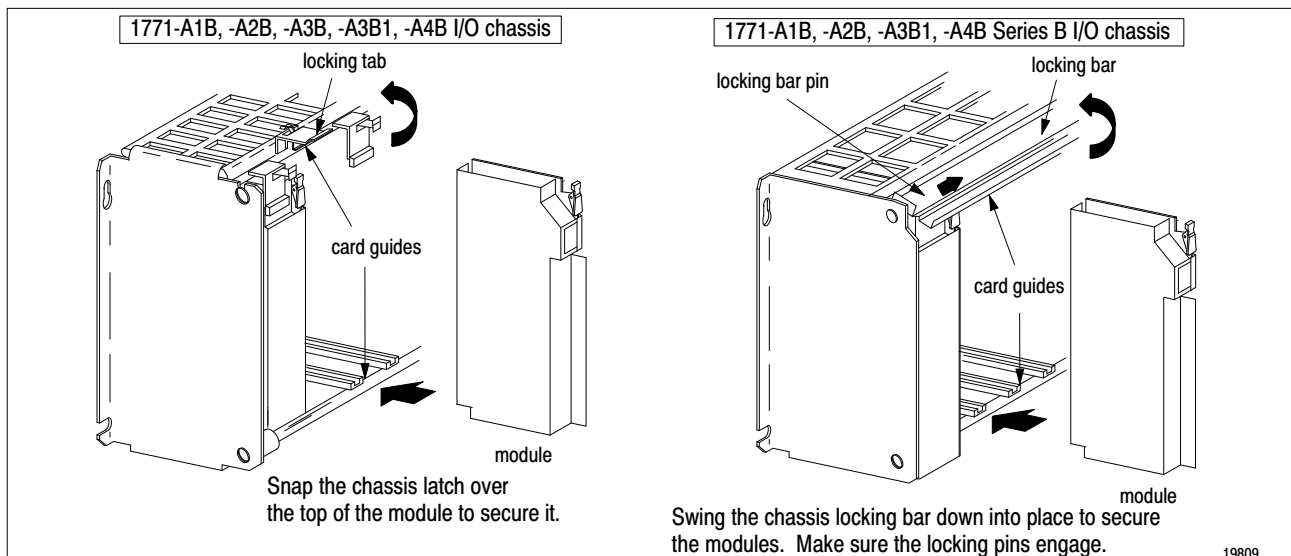

The 1771-OQ16 series C module is a modular component of the 1771 I/O system requiring a properly installed system chassis. Refer to publication 1771-IN075 for detailed information on acceptable chassis, proper installation and grounding requirements. Limit the maximum adjacent slot power dissipation to 10W maximum.

Connect Wiring to the Output Module

Make wiring connections to terminals on the field wiring arm (cat. no. 1771-WN) shipped with the module.

Attach the wiring arm to the pivot bar on the bottom of the I/O chassis. The wiring arm pivots upward and connects with the module so you can install or remove the module without disconnecting the wires.

1. Make certain all power is removed from the module before making wiring connections.
2. Swing the wiring arm up into position on the front of the module. The locking tab on the module will secure it into position.
3. Make connections to the field wiring arm as shown in the connection diagram below. (Use the label on the front of the wiring arm to identify your wiring.)

ATTENTION

The field wiring arm terminal identification number is not the same as the number of the bit which controls that output. You should identify the labels on the wiring arm with the name or number of the device connected at each terminal.

You can use an output of the 1771-OQ16 module to drive an input of a dc input module (1771-IQ16) to indicate status, such as the turning on of a motor starter (see below).

Driving an Input with an Output

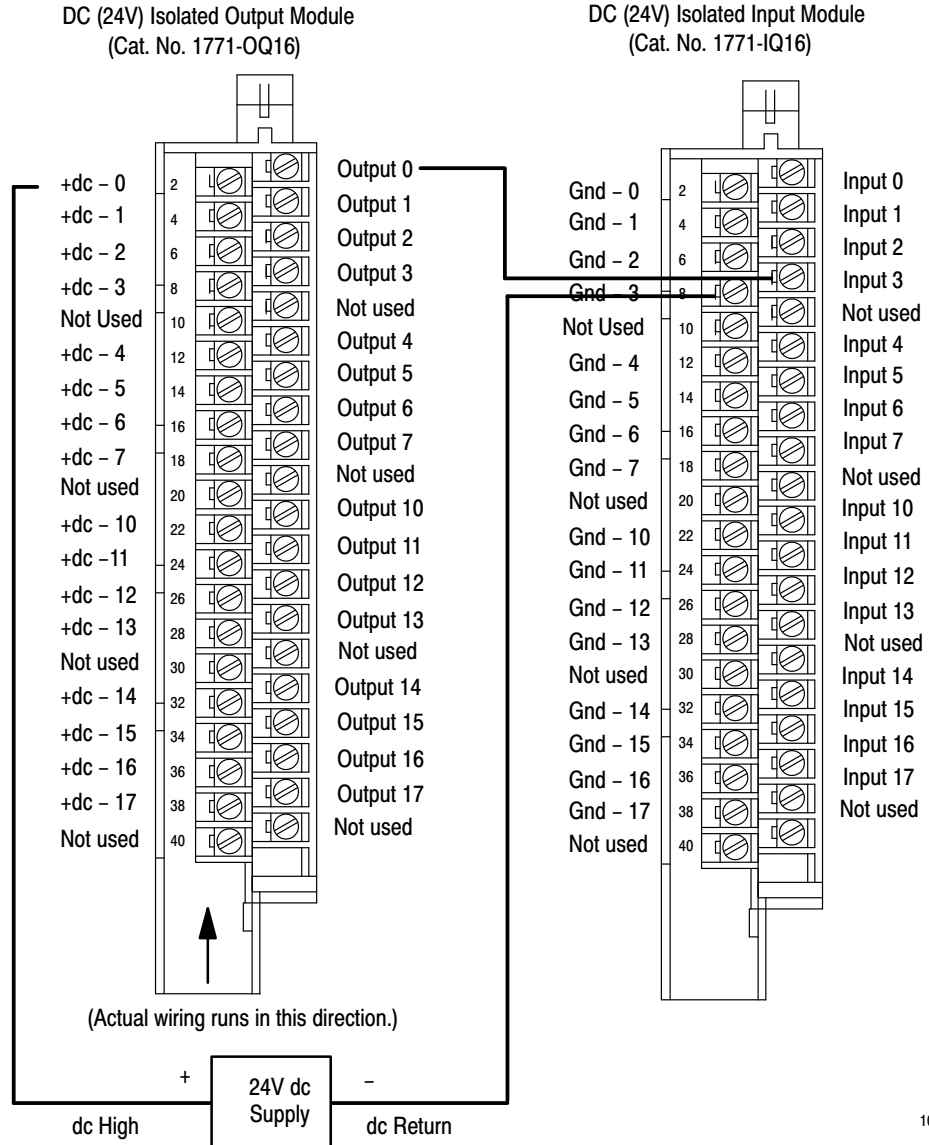

ATTENTION

Use copper wires suitable for 35°C above surrounding ambient.



Interpreting the Status Indicators

The module has 18 indicators, consisting of 16 output status indicators, an active indicator and a fuse blown indicator. The 16 status indicators will light when an "on" signal has been communicated between the module and the system backplane.

Status Indicators

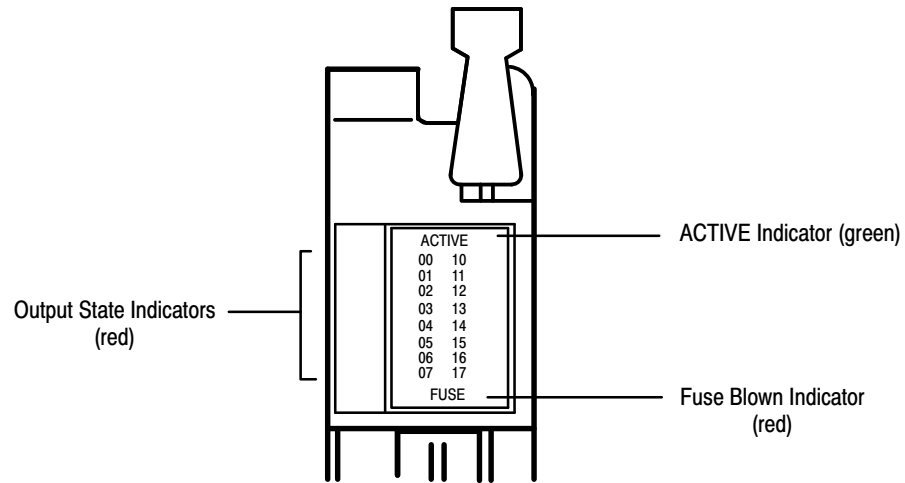

10567-I

The ACTIVE indicator will light when the module has started up and successfully initialized. The FUSE blown indicator will light when the fuse has cleared or been removed and the channel associated with that fuse has been turned "on." The fuse-blown circuit will not operate if the applied voltage to that channel is above the specified minimum "on-state" voltage, and the output load current is less than or equal to 5mA. The FUSE blown indicator will reset after the fuse has been replaced and chassis power has been cycled.

Replacing a Fuse

Each module output is individually fused. You can easily access the module fuses through the access hole provided in the component side cover. Follow the procedure below.

ATTENTION



Remove power from the 1771 I/O chassis backplane and wiring arm before removing or installing an I/O module.

- Failure to remove power from the backplane could cause injury or equipment damage due to possible unexpected operation.
- Failure to remove power from the backplane or wiring arm could cause module damage, degradation of performance, or injury.

If a blown fuse occurs:

1. Turn off power to the I/O chassis backplane.
2. Pivot the wiring arm away from the module and pull the module from the I/O chassis.
3. Use a small common screwdriver to reach through the front of the module and carefully pry one end of the fuse out of its holder.

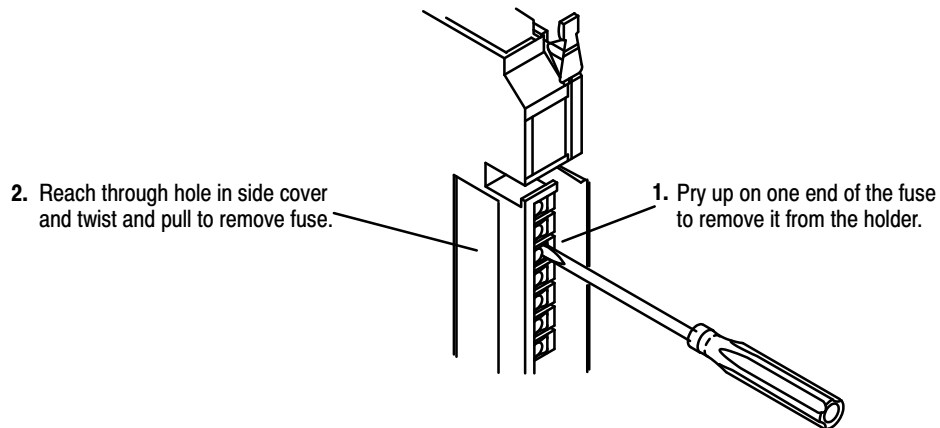

18532

4. Reach through the access hole on the side of the module and carefully twist and pull to remove the blown fuse. Replace it with a 3A 2AG fast-acting fuse (Littelfuse part number 225003).
5. Reinstall the module in the I/O chassis.
6. Reposition the wiring arm.
7. Restart system power.

The following information applies when operating this equipment in hazardous locations:

Products marked “CL I, DIV 2, GP A, B, C, D” are suitable for use in Class I Division 2 Groups A, B, C, and D Hazardous Locations and nonhazardous locations only. Each product is supplied with markings on the rating nameplate indicating the hazardous location temperature code. When combining products within a system, the most adverse temperature code (lowest “T” number) may be used to help determine the overall temperature code of the system. Combinations of equipment in your system are subject to investigation by the local Authority Having Jurisdiction at the time of installation.

WARNING



EXPLOSION HAZARD -

- Do not disconnect equipment unless power has been removed or the area is known to be nonhazardous.
 - Do not disconnect connections to this equipment unless power has been removed or the area is known to be nonhazardous. Secure any external connections that mate to this equipment by using screws, sliding latches, threaded connectors, or other means provided with this product.
 - Substitution of components may impair suitability for Class I, Division 2.
 - If this product contains batteries, they must only be changed in an area known to be nonhazardous.
-

Informations sur l'utilisation de cet équipement en environnements dangereux:

Les produits marqués CL I, DIV 2, GP A, B, C, D ne conviennent que une utilisation en environnements de Classe I Division 2 Groupes A, B, C, D dangereux et non dangereux. Chaque produit est livré avec des marquages sur sa plaque d'identification qui indiquent le code de température pour les environnements dangereux. Lorsque plusieurs produits sont combinés dans un système, le code de température le plus défavorable (code de température le plus faible) peut être utilisé pour déterminer le code de température global du système. Les combinaisons d'équipements dans le système sont sujettes à inspection par les autorités locales qualifiées au moment de l'installation.

AVERTISSEMENT



RISQUE D'EXPLOSION -

- Couper le courant ou s'assurer que l'environnement est classé non dangereux avant de débrancher l'équipement.
 - Couper le courant ou s'assurer que l'environnement est classé non dangereux avant de débrancher les connecteurs. Fixer tous les connecteurs externes reliés à cet équipement à l'aide de vis, loquets coulissants, connecteurs filetés ou autres moyens fournis avec ce produit.
 - La substitution de composants peut rendre cet équipement inadapté à une utilisation en environnement de Classe 1, Division 2.
 - S'assurer que l'environnement est classé non dangereux avant de changer les piles.
-

Specifications

Outputs per Module	16
Module Location	1771-A1B thru - A1B or later I/O Chassis
Voltage Rating	10 to 32V dc
Maximum Output Current	2.0A per output; 32.0A maximum per module at 0–45°C; Derate linearly to 1.5A per output, 24A maximum per module at 60°C – See derating curve.
Minimum Output Current	5mA
On-state Voltage Drop (maximum)	0.34A per output at 2A
Off-state Leakage Current (maximum)	0.5mA per output @ 32V dc, 25°C
Surge Current (maximum)	4A for 10ms per output., repeatable every 2 sec.
Power Rating	0.68W per output (maximum) @ 2A
Output Signal Delay Off to On On to Off	100µs (max); 300µs (max)
Power Dissipation	13.0 Watts (max); 2.0 Watts (min)
Thermal Dissipation	44.3 BTU/hr (max); 6.8 BTU/hr (min)
Adjacent Slot Power Dissipation	10.0 Watts
Backplane Current	400mA maximum
Isolation Voltage	Tested for 1s at 1500V channel-to-channel, 1500V channel to backplane
Maximum Cable Length	1000 ft (304.8 m)
Conductors Wire Size	14 to 22 gauge (2.5mm ² to 0.25mm ²) stranded or solid copper wire rated at 60°C or greater ^{1, 2}
Category	3/64 inch insulation maximum 2 ³
Environmental Conditions	
Operating Temperature	IEC 60068–2–1 (Test Ad, Operating Cold) IEC 60068–2–2 (Test Bd, Operating Dry Heat) IEC 60068–2–14 (Test Nb, Operating Thermal Shock) 32 to 140°F (0° to 60°C) See derating curve.
Storage Temperature	IEC 60068–2–1 (Test Ab, Unpackaged, Nonoperating Cold) IEC 60068–2–2 (Test Bb, Unpackaged, Nonoperating Dry Heat) IEC 60068–2–14 (Test Na, Unpackaged, Nonoperating Thermal Shock) –40 to 185°F (–40 to 85°C)
Relative Humidity	IEC 60068–2–30 (Test Db, Unpackaged, Nonoperating Damp Heat) 5 to 95%, noncondensing
Shock Operating Nonoperating	IEC 60068–2–27 (Test Ea, Unpackaged Shock) 30g 50g
Vibration	IEC 60068–2–6 (Test Fc, Operating) 2g @ 10–500Hz
ESD Immunity	IEC 61000–4–2 4kV indirect discharges
Radiated RF Immunity	IEC 61000–4–3 10V/m, with 1kHz sine-wave 80% AM from 30MHz to 1000MHz
EFT/B Immunity	IEC 61000–4–4 +1kV @ 5kHz on signal ports
Surge Transient Immunity	IEC 61000–4–5 +1kV line–line (DM) and +2kV line–earth (CM) on signal ports
Specifications continued on next page.	

Conducted RF Immunity	IEC 61000-4-6 10V rms with 1kHz sine wave 80% AM from 150kHz to 30MHz
Emissions	CISPR 11 Group 1, Class A (with appropriate enclosure)
Enclosure Type Rating	None (open-style)
Keying	Between 22 and 24 Between 32 and 34
Fuse	3A 2AG Fast Acting fuses (1 per output) Littelfuse P/N 225003 (Optional fuse kit Cat No. 1771-FF contains 5 fuses)
Field Wiring Arm	Catalog Number 1771-WN
Wiring Arm Screw Torque	7-9 pound-inches (0.8-1.0Nm)
Certifications (when product is marked)	<ul style="list-style-type: none"> UL UL Listed Industrial Control Equipment CSA CSA Certified Process Control Equipment CSA CSA Certified Process Control Equipment for Class I, Division 2 Group A, B, C, D Hazardous Locations CE⁴ European Union 89/336/EEC EMC Directive, compliant with: EN 50082-2, Industrial Immunity EN 61236, Meas./Control/Lab., Industrial Requirements EN 61000-6-2, Industrial Immunity EN 61000-6-4, Industrial Emissions C-Tick⁴ Australian Radiocommunications Act, compliant with: AS/NZS 2064, Industrial Emissions

¹ One or two 14-22 AWG solid or stranded copper wires per terminal. Must be same size. Do not intermix solid and stranded wires. Use copper wire only.

² 14AWG connected to all terminals may not allow the field wiring arm cover to close. A smaller wire size may be required.

³ You use this conductor category information for planning conductor routing as described in publication 1770-4.1, Industrial Automation Wiring and Grounding Guidelines.

⁴ See the Product Certification link at www.ab.com for Declarations of Conformity, Certificates and other certification details

Derating Curve for the 1771-QQ16/C

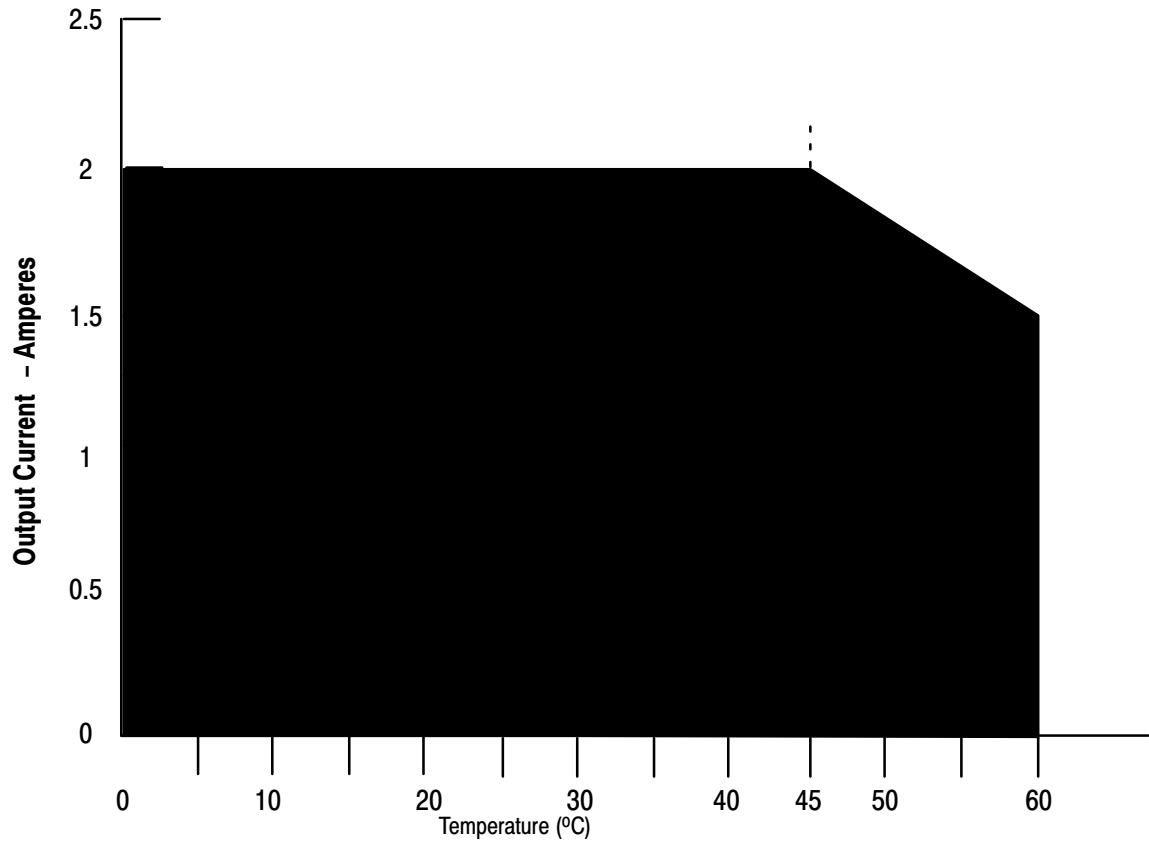

www.rockwellautomation.com

Power, Control and Information Solutions Headquarters

Americas: Rockwell Automation, 1201 South Second Street, Milwaukee, WI 53204-2496 USA, Tel: (1) 414.382.2000, Fax: (1) 414.382.4444

Europe/Middle East/Africa: Rockwell Automation, Vorstlaan/Boulevard du Souverain 36, 1170 Brussels, Belgium, Tel: (32) 2 663 0600, Fax: (32) 2 663 0640

Asia Pacific: Rockwell Automation, Level 14, Core F, Cyberport 3, 100 Cyberport Road, Hong Kong, Tel: (852) 2887 4788, Fax: (852) 2508 1846