



Ferrite Collar (Catalog Number 1747-FC)

The ferrite collar is intended for use with an RS-232 cable (catalog number 1747-CP3) connected to a 1747-L541, 1747-L542, 1747-L543 processor.

Install the collar for suppression of electromagnetic emissions and interference. The collar is required for compliance with the European EMC Directive.

To be effective, the ferrite collar must be placed on the cable where the cable exits the module (see figure).

1. Fold the collar so that it encircles the cable.
2. Press the plastic housing until the collar snaps together.
3. Check that the collar is fully latched.

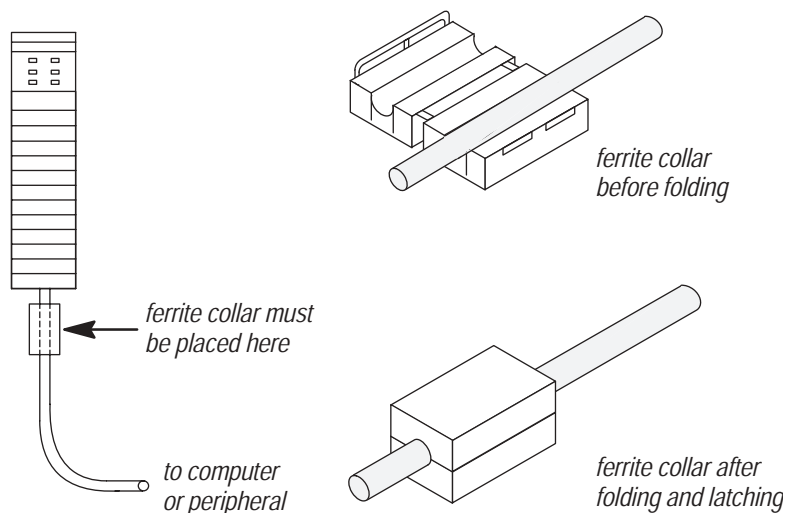

www.rockwellautomation.com

Power, Control and Information Solutions Headquarters

Americas: Rockwell Automation, 1201 South Second Street, Milwaukee, WI 53204-2496 USA, Tel: (1) 414.382.2000, Fax: (1) 414.382.4444

Europe/Middle East/Africa: Rockwell Automation, Vorstlaan/Boulevard du Souverain 36, 1170 Brussels, Belgium, Tel: (32) 2 663 0600, Fax: (32) 2 663 0640

Asia Pacific: Rockwell Automation, Level 14, Core F, Cyberport 3, 100 Cyberport Road, Hong Kong, Tel: (852) 2887 4788, Fax: (852) 2508 1846

Publication 1747-5.6 - December 1995

PN 40071-021-01(A)

Copyright © 2007 Rockwell Automation, Inc. All rights reserved. Printed in Singapore.