



FLEX™ I/O Isolated Input/Output Analog Module

Cat. No. 1794-IF2XOF2I

Important User Information

Solid state equipment has operational characteristics differing from those of electromechanical equipment. Safety Guidelines for the Application, Installation and Maintenance of Solid State Controls (Publication SGI-1.1 available from your local Rockwell Automation sales office or online at <http://www.rockwellautomation.com/literature/>) describes some important differences between solid state equipment and hard-wired electromechanical devices. Because of this difference, and also because of the wide variety of uses for solid state equipment, all persons responsible for applying this equipment must satisfy themselves that each intended application of this equipment is acceptable.

In no event will Rockwell Automation, Inc. be responsible or liable for indirect or consequential damages resulting from the use or application of this equipment.

The examples and diagrams in this manual are included solely for illustrative purposes. Because of the many variables and requirements associated with any particular installation, Rockwell Automation, Inc. cannot assume responsibility or liability for actual use based on the examples and diagrams.

No patent liability is assumed by Rockwell Automation, Inc. with respect to use of information, circuits, equipment, or software described in this manual.

Reproduction of the contents of this manual, in whole or in part, without written permission of Rockwell Automation, Inc., is prohibited.

Throughout this manual we use notes to make you aware of safety considerations.

WARNING 	Identifies information about practices or circumstances that can cause an explosion in a hazardous environment, which may lead to personal injury or death, property damage, or economic loss.
ATTENTION 	Identifies information about practices or circumstances that can lead to personal injury or death, property damage, or economic loss. Attentions help you: <ul style="list-style-type: none"> • identify a hazard • avoid a hazard • recognize the consequence
IMPORTANT	Identifies information that is critical for successful application and understanding of the product.
SHOCK HAZARD 	Labels may be located on or inside the equipment (for example, drive or motor) to alert people that dangerous voltage may be present.
BURN HAZARD 	Labels may be located on or inside the equipment (for example, drive or motor) to alert people that surfaces may be dangerous temperatures.

ATTENTION



Environment and Enclosure

This equipment is intended for use in a Pollution Degree 2 industrial environment, in overvoltage Category II applications (as defined in IEC publication 60664-1), at altitudes up to 2000 m (6562 ft) without derating.

This equipment is considered Group 1, Class A industrial equipment according to IEC/CISPR Publication 11. Without appropriate precautions, there may be potential difficulties ensuring electromagnetic compatibility in other environments due to conducted as well as radiated disturbance.

This equipment is supplied as open-type equipment. It must be mounted within an enclosure that is suitably designed for those specific environmental conditions that will be present and appropriately designed to prevent personal injury resulting from accessibility to live parts. The enclosure must have suitable flame-retardant properties to prevent or minimize the spread of flame, complying with a flame spread rating of 5VA, V2, V1, V0 (or equivalent) if non-metallic. The interior of the enclosure must be accessible only by the use of a tool. Subsequent sections of this publication may contain additional information regarding specific enclosure type ratings that are required to comply with certain product safety certifications.

In addition to this publication, see:

- Industrial Automation Wiring and Grounding Guidelines, publication [1770-4.1](#), for additional installation requirements.
- NEMA Standard 250 and IEC 60529, as applicable, for explanations of the degrees of protection provided by enclosures.

ATTENTION



Preventing Electrostatic Discharge

This equipment is sensitive to electrostatic discharge, which can cause internal damage and affect normal operation. Follow these guidelines when you handle this equipment:

- Touch a grounded object to discharge potential static.
- Wear an approved grounding wriststrap.
- Do not touch connectors or pins on component boards.
- Do not touch circuit components inside the equipment.
- Use a static-safe workstation, if available.
- Store the equipment in appropriate static-safe packaging when not in use.

WARNING



If you insert or remove the module while backplane power is on, an electrical arc can occur. This could cause an explosion in hazardous location installations. Be sure that power is removed or the area is nonhazardous before proceeding.

WARNING



If you connect or disconnect wiring while the field side power is on, an electrical arc can occur. This could cause an explosion in hazardous location installations. Be sure that power is removed or the area is nonhazardous before proceeding.

WARNING



For Class I Division 2 applications, use only Class I Division 2 listed or recognized accessories and modules approved for used within the 1794 platform.

ATTENTION



Personnel responsible for the application of safety-related programmable electronic systems (PES) shall be aware of the safety requirements in the application of the system and shall be trained in using the system.

ATTENTION

If multiple power sources are used, do not exceed the specified isolation voltage.



European Hazardous Location Approval

The following applies when the product bears the Ex Marking.

This equipment is intended for use in potentially explosive atmospheres as defined by European Union Directive 94/9/EC and has been found to comply with the Essential Health and Safety Requirements relating to the design and construction of Category 3 equipment intended for use in Zone 2 potentially explosive atmospheres, given in Annex II to this Directive.

Compliance with the Essential Health and Safety Requirements has been assured by compliance with EN 60079-15 and EN 60079-0.

WARNING

Observe the following additional certification requirements:



- This equipment is not resistant to sunlight or other sources of UV radiation.
- This equipment must be installed in an enclosure providing at least IP54 protection when applied in Zone 2 environments.
- This equipment shall be used within its specified ratings defined by Rockwell Automation.
- This equipment must be used only with ATEX certified Rockwell Automation terminal bases.
- Secure any external connections that mate to this equipment by using screws, sliding latches, threaded connectors, or other means provided with this product.
- Do not disconnect equipment unless power has been removed or the area is known to be nonhazardous.
- Provision shall be made to prevent the rated voltage from being exceeded by transient disturbances of more than 40% when applied in Zone 2 environments.

North American Hazardous Location Approval

The 1794-IF2XOF2I module is hazardous location approved.

The following information applies when operating this equipment in hazardous locations:

Products marked "CL I, DIV 2, GP A, B, C, D" are suitable for use in Class I Division 2 Groups A, B, C, D, Hazardous Locations and nonhazardous locations only. Each product is supplied with markings on the rating nameplate indicating the hazardous location temperature code. When combining products within a system, the most adverse temperature code (lowest "T" number) may be used to help determine the overall temperature code of the system. Combinations of equipment in your system are subject to investigation by the local Authority Having Jurisdiction at the time of installation.

Informations sur l'utilisation de cet équipement en environnements dangereux :

Les produits marqués "CL I, DIV 2, GP A, B, C, D" ne conviennent qu'à une utilisation en environnements de Classe I Division 2 Groupes A, B, C, D dangereux et non dangereux. Chaque produit est livré avec des marquages sur sa plaque d'identification qui indiquent le code de température pour les environnements dangereux. Lorsque plusieurs produits sont combinés dans un système, le code de température le plus défavorable (code de température le plus faible) peut être utilisé pour déterminer le code de température global du système. Les combinaisons d'équipements dans le système sont sujettes à inspection par les autorités locales qualifiées au moment de l'installation.

WARNING



EXPLOSION HAZARD

- Do not disconnect equipment unless power has been removed or the area is known to be nonhazardous.
- Do not disconnect connections to this equipment unless power has been removed or the area is known to be nonhazardous. Secure any external connections that mate to this equipment by using screws, sliding latches, threaded connectors, or other means provided with this product.
- Substitution of components may impair suitability for Class I, Division 2.
- If this product contains batteries, they must only be changed in an area known to be nonhazardous.

AVERTISSEMENT



RISQUE D'EXPLOSION

- Couper le courant ou s'assurer que l'environnement est classé non dangereux avant de débrancher l'équipement.
- Couper le courant ou s'assurer que l'environnement est classé non dangereux avant de débrancher les connecteurs. Fixer tous les connecteurs externes reliés à cet équipement à l'aide de vis, loquets coulissants, connecteurs filetés ou autres moyens fournis avec ce produit.
- La substitution de composants peut rendre cet équipement inadéquat à une utilisation en environnement de Classe I, Division 2.
- S'assurer que l'environnement est classé non dangereux avant de changer les piles.

Install the Analog Input/Output Module

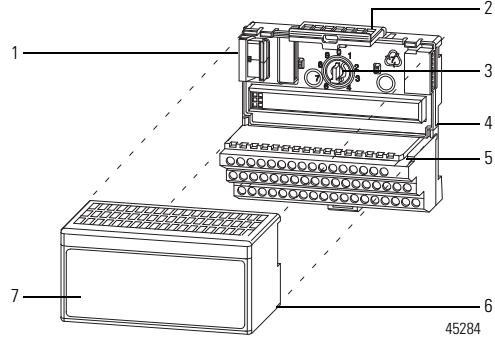

Description	Description
1 FlexBus connectors	5 Groove
2 Latching mechanism	6 Alignment bar
3 Keyswitch	7 Module
4 Terminal base	

The module mounts on a 1794 terminal base.

1. Rotate the keyswitch (3) on the terminal base (4) clockwise to position 5 as required for this type of module.
2. Make sure the FlexBus connector (1) is pushed all the way to the left to connect with the neighboring terminal base/adaptor. **You cannot install the module unless the connector is fully extended.**
3. Make sure the pins on the bottom of the module are straight so they will align properly with the connector in the terminal base.
4. Position the module (7) with its alignment bar (6) aligned with the groove (5) on the terminal base.
5. Press firmly and evenly to seat the module in the terminal base unit. The module is seated when the latching mechanism (2) is locked into the module.

ATTENTION



Do not remove or replace a Terminal Base unit while power is applied. Interruption of the backplane can result in unintentional operation or machine motion.

ATTENTION



This product is grounded through the DIN rail to chassis ground. Use zinc plated yellow-chromate steel DIN rail to assure proper grounding. The use of other DIN rail materials (for example, aluminum or plastic) that can corrode, oxidize, or are poor conductors, can result in improper or intermittent grounding. Secure DIN rail to mounting surface approximately every 200 mm (7.8 in.) and use end-anchors appropriately.

Connect Wiring for the Analog Inputs and Outputs

1. **1794-TB2, 1794-TB3, 1794-TB3S, 1794-TB3T, and 1794-TB3TS:** Connect individual input/output wiring to numbered terminals on the 0...15 row (A) as indicated in the [Wiring Connections for 1794-IF2XOF2I Input/Output Module](#) table. Use Belden 8761 cable for signal wiring.
1794-TBN: Connect individual input/output wiring to even-numbered terminals on the 16...33 row (B) as indicated in the [Wiring Connections for 1794-IF2XOF2I Input/Output Module](#) table. Use Belden 8761 cable for signal wiring.

ATTENTION



Connect only one current and one voltage signal per channel. Do not connect both current and voltage on one channel.

- 1794-TB2, 1794-TB3, 1794-TB3S, 1794-TB3T, 1794-TB3TS: Connect each channel signal return to numbered terminals on the 0...15 row (A) as indicated in the [Wiring Connections for 1794-IF2XOF2I Input/Output Module](#) table. Use Belden 8761 cable for signal wiring.
1794-TBN: Connect each channel signal return to odd-numbered terminals on row (C) as indicated in the [Wiring Connections for 1794-IF2XOF2I Input/Output Module](#) table.
- Connect any signal wiring shields to functional ground as near as possible to the module.
1794-TB3T or 1794-TB3TS only: Connect to earth ground terminals C-39...C-46.
- Connect the +V DC power to terminal 34 on the 34...51 row (C) and -V common/return to terminal 16 on the B row.

ATTENTION



To reduce susceptibility to noise, power analog modules and digital modules from separate power supplies.

- If daisy chaining power to the next terminal base, connect a jumper from terminal 51 (+V DC) on this base unit to terminal 34 on the next base unit.
- If continuing DC common (-V) to the next base unit, connect a jumper from terminal 33 (common) on this base unit to terminal 16 on the next base unit.

Wiring Connections for 1794-IF2XOF2I Input/Output Module

Channel	Signal Type	Label Markings	1794-TB2, 1794-TB3, 1794-TB3S, 1794-TB3T, 1794-TB3TS		1794-TBN
			Terminal	Shield (1794-TB3T, 1794-TB3TS)	Terminal
Input 0	Current	I0	A-0	C-39	B-0
	Current	I0 ret	A-1		C-1
	Voltage	V0	A-2	C-40	B-2
	Voltage	V0 ret	A-3		C-3
Input 1	Current	I1	A-4	C-41	B-4
	Current	I1 ret	A-5		C-5
	Voltage	V1	A-6	C-42	B-6
	Voltage	V1 ret	A-7		C-7
Output 0	Current	I2	A-8	C-43	B-8
	Current	I2 ret	A-9		C-9
	Voltage	V2	A-10	C-44	B-10
	Voltage	V2 ret	A-11		C-11
Output 1	Current	I3	A-12	C-45	B-12
	Current	I3 ret	A-13		C-13
	Voltage	V3	A-14	C-46	B-14
	Voltage	V3 ret	A-15		C-15
-V DC common	1794-TB2, 1794-TB3, 1794-TB3S: Terminals B-16...B-33 are internally connected in the terminal base unit. 1794-TBN: Terminals B-16 and B-33 are internally connected in the terminal base unit. 1794-TB3T, 1794-TB3TS: Terminals 16, 17, 19, 21, 23, 25, 27, 29, 31 and 33 are internally connected in the terminal base unit.				
+V DC power	1794-TB3, 1794-TB3S: Terminals 34...51 are internally connected in the terminal base unit. 1794-TB3T, 1794-TB3TS: Terminals 34, 35, 50 and 51 are internally connected in the terminal base unit. 1794-TBN, 1794-TB2: Terminals 34 and 51 are internally connected in the terminal base unit.				
Chassis ground (shield)	1794-TB3T, 1794-TB3TS: Terminals 39...46 are internally connected to chassis ground.				

1794-TB2, 1794-TB3, 1794-TB3S, 1794-TB3T and 1794-TB3TS Terminal Base Wiring

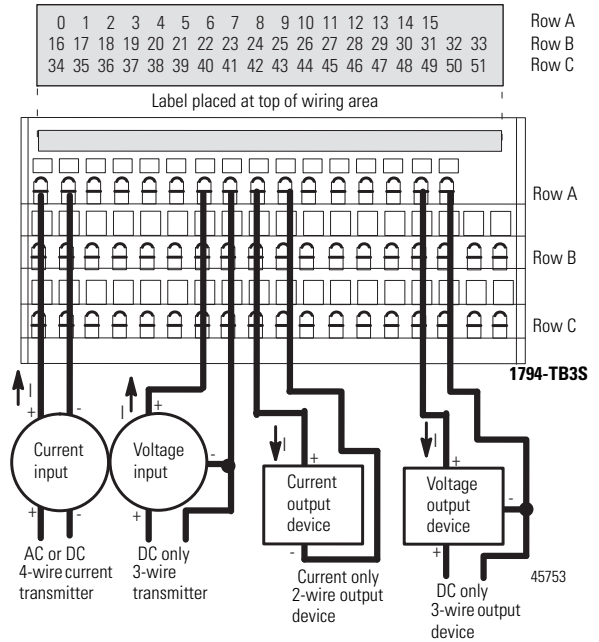

1794-TBN Terminal Base Wiring

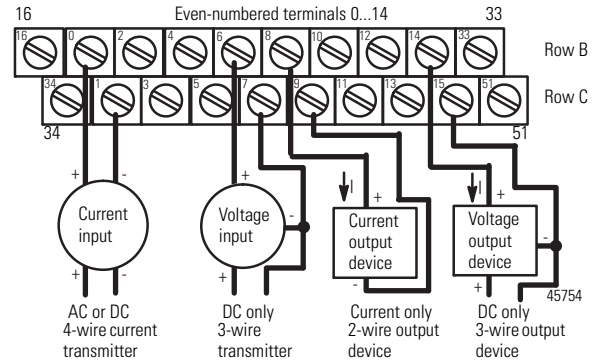

Input Map

Dec	15	14	13	12	11	10	9	8	7	6	5	4	3	2	1	0	
Oct	17	16	15	14	13	12	11	10	7	6	5	4	3	2	1	0	
Word 0	Analog value for input channel 0																
Word 1	Analog value for input channel 1																
Word 2	Read back output channel 0																
Word 3	Read back output channel 1																
Word 4	0	Real-time sample															
Word 5	PU	FP	CF	0	Reserved				0	0	0	0	0	0	BD	DN	0
Word 6	0	0	0	0	P1	P0	0	0	0	0	V1	V0	W1	W0	U1	U0	

Where:
 PU = Power up/inconfigured
 FP = Field power off
 CF = In configuration mode
 BD = Calibration bad
 DN = Calibration done
 U = Under range for specified channel
 W = Wire off current loop status for output channels 0 and 1
 V = Over range for specified channel
 P = Outputs holding in response to Q0 and Q1

Output Map

Dec	15	14	13	12	11	10	9	8	7	6	5	4	3	2	1	0
Oct	17	16	15	14	13	12	11	10	7	6	5	4	3	2	1	0
Word 0	EN	S1	S0	0	0	0	0	0	0	0	0	0	0	0	0	0
Word 1	Analog output data - channel 0															
Word 2	Analog output data - channel 1															
Word 3	0	0	0	0	0	0	0	0	Input channel 1 filter				Input channel 0 filter			

Output Map

Dec	15	14	13	12	11	10	9	8	7	6	5	4	3	2	1	0
Oct	17	16	15	14	13	12	11	10	7	6	5	4	3	2	1	0
Word 4	Output channel 1 configuration				Output channel 0 configuration				Input channel 1 configuration				Input channel 0 configuration			
Word 5	Real time sample programmed interval															
Word 6	IC	1	TR	IT	Q1	Q0	0	0	RV	QK	CK	GO	Channel number			
Where:	EN = Output enable bit S0 and S1 = Safe state source bits TR = Transparent bit IT = Interrupt toggle bit IC = Initiate configuration bit Q0 and Q1 = Requests for outputs to hold RV = Revert to defaults bits QK = Quick calibration CK = Calibration clock GO = Gain offset select															

Configure the Input Channels

Input Channel Configuration																			
03	02	01	00	Set these bits for channel 0															
07	06	05	04	Set these bits for channel 1															
Configuration Bits				Nominal Range				Data Type				% Underrange % Overage				Output Values			
MSD				LSD															
0	0	0	1	4...20 mA				Signed 2's complement				4% under; 4% over				<0000...7878>			
0	0	1	0	±10V								2% under; 2% over				<831F...7CE1>			
0	0	1	1	±5V								4% under; 4% over				<8618...79E8>			
0	1	0	0	0...20 mA				Signed 2's complement %				0% under; 4% over				<0...10000>			
0	1	0	1	4...20 mA								4% under; 4% over				<0...10000>			
0	1	1	0	0...10V								0% under; 2% over				0...10000			
0	1	1	1	±10V								2% under; 2% over				<-10000...10000>			
1	0	0	0	0...20 mA				Binary				0% under; 4% over				0000...F3CF			
1	0	0	1	4...20 mA								4% under; 4% over				0000...F0F1			
1	0	1	0	0...10V								0% under; 2% over				0000...F9C2			
1	0	1	1	0...5V								0% under; 4% over				0000...F3CF			
1	1	0	0	±20 mA				Offset binary, 8000H = 0 mA				4% under; 4% over				<8000...F9E8>			
1	1	0	1	4...20 mA				Offset binary, 8000H = 4 mA				4% under; 4% over				<8000...F878>			
1	1	1	0	±10V				Offset binary, 8000H = 0 V				2% under; 2% over				<031F...FCE1>			
1	1	1	1	±5V								4% under; 4% over				<0618...F9E8>			

Update Rate for Real Time Sample Interval = 0

Configuration Bits				Nominal Ranges				Channel Update Rate⁽¹⁾							
MSD				LSD											
								RTSI = 0 and No Low Pass Filter				RTSI and Filter = 0 IT Bit = 1			
0	0	0	1	4...20 mA				7.5 ms				5.0 ms			
0	0	1	0	±10V				2.5 ms				2.5 ms			
0	0	1	1	±5V				2.5 ms				2.5 ms			
0	1	0	0	0...20 mA				7.5 ms				5.0 ms			
0	1	0	1	4...20 mA				7.5 ms				5.0 ms			
0	1	1	0	0...10V				5.0 ms				5.0 ms			
0	1	1	1	±10V				5.0 ms				5.0 ms			
1	0	0	0	0...20 mA				2.5 ms				2.5 ms			
1	0	0	1	4...20 mA				7.5 ms				5.0 ms			
1	0	1	0	0...10V				2.5 ms				2.5 ms			
1	0	1	1	0...5V				2.5 ms				2.5 ms			
1	1	0	0	±20 mA				2.5 ms				2.5 ms			
1	1	0	1	4...20 mA				7.5 ms				5.0 ms			
1	1	1	0	±10V				2.5 ms				2.5 ms			
1	1	1	1	±5V				2.5 ms				2.5 ms			

⁽¹⁾ When IT = 1, the channel update rate for all channels is determined by the slowest channel.

Set the Input Filters

Input Channel Filter															
03	02	01	00	Set these bits for channel 0											
07	06	05	04	Set these bits for channel 1											
Bit Settings				A/D Conversion Rate				Low Pass Filter							
0	0	0	0	1200 Hz				No low pass							
0	0	0	1	1200 Hz				100 ms low pass							
0	0	1	0	1200 Hz				500 ms low pass							
0	0	1	1	1200 Hz				1000 ms low pass							
0	1	0	0	600 Hz				No low pass							
0	1	0	1	600 Hz				100 ms low pass							
0	1	1	0	600 Hz				500 ms low pass							
0	1	1	1	600 Hz				1000 ms low pass							
1	0	0	0	300 Hz				No low pass							
1	0	0	1	300 Hz				100 ms low pass							
1	0	1	0	300 Hz				500 ms low pass							
1	0	1	1	300 Hz				1000 ms low pass							
1	1	0	0	150 Hz				No low pass							
1	1	0	1	150 Hz				100 ms low pass							
1	1	1	0	150 Hz				500 ms low pass							
1	1	1	1	150 Hz				1000 ms low pass							

Configure the Output Channels

Output Range Selection and Update Rate																			
11	10	09	08	Set these bits for channel 0															
15	14	13	12	Set these bits for channel 1															
Configuration Bits				Nominal Range				Data Type				Output Values				Module Update Rate			
MSD				LSD															
0	0	0	1	4...20 mA				Signed 2's complement				<0000...7878>				5.0 ms			
0	0	1	0	±10V								<8618...79E8>				2.5 ms			
0	0	1	1	±5V								<8618...79E8>				2.5 ms			
0	1	0	0	0...20 mA				Signed 2's complement %				0...10000				5.0 ms			
0	1	0	1	4...20 mA								<0...10000>				5.0 ms			
0	1	1	0	0...10V								<-10000...10000>				5.0 ms			
0	1	1	1	±10V								<-10000...10000>				5.0 ms			
1	0	0	0	0...20 mA				Binary				0000...F3CF				2.5 ms			
1	0	0	1	4...20 mA								0000...F0F1				5.0 ms			
1	0	1	0	0...10V								0000...F3CF				2.5 ms			
1	0	1	1	0...5V								0000...F3CF				2.5 ms			
1	1	0	0	0...20 mA				Offset binary				<8000...F9E8>				2.5 ms			
1	1	0	1	4...20 mA								<8000...F878>				5.0 ms			
1	1	1	0	±10V								<0618...F9E8>				2.5 ms			
1	1	1	1	±5V								<0618...F9E8>				2.5 ms			

Status Indicator

The OK status indicator is two-colored: red and green. The indicator flashes green for one of three reasons:

1. The module configuration word is zero (for example, power up reset condition).
2. The 24V DC user power is off.
3. The module is in configuration mode.

The indicator displays red to indicate that the module did not pass the initial hardware test. Cycle power again.

After power up, if the status indicator is not flashing green or solid green, cycle module power once more to verify a proper reset of the bus interface.

Specifications

General Specifications

Attribute	Value
Module location	1794-TB2, 1794-TB3, 1794-TB3S, 1794-TB3T, 1794-TB3TS, or 1794-TBN terminal base.
FlexBus voltage	5V DC
FlexBus current	50 mA
External DC power supply, nom voltage range	24V DC 19.2...31.2V DC (includes 5% AC ripple)
External DC power supply current	150 mA @ 24V DC
Thermal dissipation, max	11.3 BTU/hr @ 31.2V DC
Power dissipation, max	3.3 W @ 31.2V DC

General Specifications

Isolation voltage	120V (continuous), Basic Insulation Type, channel to channel, channel to user, channel to system, and user power to system when used with 1794-TB2, 1794-TB3, 1794-TB3S, 1794-TB3T, or 1794-TB3TS. 250V (continuous), Basic Insulation Type, channel to channel, channel to user, channel to system, and user power to system when used with 1794-TBN. Type tested at 1000V AC for 60 s.
Indicators	1 red/green power/status indicator
Keyswitch position	5
Dimensions, with module installed in base; HxWxD	94.0 x 94.0 x 66.0 mm (3.7 x 3.7 x 2.6 in.)
Calibration	Factory-calibrated for 150 Hz, 300 Hz, and 600 Hz. Can be recalibrated when necessary.
Conductor category ⁽¹⁾	2 – on signal ports 2 – on power ports
Conductor wire size	Determined by installed terminal base
Wire type	Shielded on signal ports
North American temp code	T4A
IEC temp code	T4

⁽¹⁾ Use this conductor category information for planning conductor routing. Refer to Industrial Automation Wiring and Grounding Guidelines, publication 1770-4.1.

Input Specifications

Attribute	Value
Number of inputs	2 isolated
Resolution Voltage Current	16 bits – unipolar; 15 bits plus sign – bipolar 0.156 mV/cnt unipolar; 0.313 mV/cnt bipolar 0.320 μ A/cnt unipolar; 0.640 μ A/cnt bipolar
Data format	2's complement 2's complement % Binary Offset binary
Conversion type	Sigma Delta
Update rate	2.5/5.0/7.5 ms all channels (see Update Rate for Real Time Sample Interval = 0 table)
Input current terminal	4...20 mA (user configurable) 0...20 mA (user configurable) \pm 20 mA (user configurable)
Input voltage terminal	\pm 10V (user configurable) 0...10V (user configurable) \pm 5V (user configurable) 0...5V (user configurable)
Normal mode rejection ratio – voltage or current terminal	-3 dB @ 12 Hz (300 Hz conversion rate) -80 dB @ 50 Hz (300 Hz conversion rate) -3 dB @ 6 Hz (150 Hz conversion rate) -80 dB @ 60 Hz (150 Hz conversion rate)
Common mode rejection ratio	-120 dB @ 50/60 Hz
Step response to 63% – voltage or current terminal	1200 Hz conversion rate = 0.6 ms 600 Hz conversion rate = 6.7 ms 300 Hz conversion rate = 13.4 ms 150 Hz conversion rate = 26.7 ms
Input resistance Voltage terminal Current terminal	>10 M Ω <100 Ω ⁽²⁾
Absolute accuracy ⁽¹⁾ Voltage terminal Current terminal	0.1% full scale @ 25 °C 0.1% full scale @ 25 °C
Accuracy drift w/temperature Voltage terminal Current terminal	0.0028% full scale/°C 0.0038% full scale/°C

⁽¹⁾ Includes offset, gain, non-linearity and repeatability error terms.

⁽²⁾ If 24V DC is removed from the module, input resistance = 10 k Ω

Output Specifications

Attribute	Value
Number of outputs	2 isolated
Resolution Voltage Current	15 bits plus sign 0.320 mV/cnt 0.656 μ A/cnt

Output Specifications

Data format	2's complement 2's complement % Binary Offset binary
Conversion type	Digital-to-analog converter
Update rate	2.5/5.0 ms all channels (see Update Rate for Real Time Sample Interval = 0 table)
Output current terminal	0 mA output until module is configured 4...20 mA (user configurable) 0...20 mA (user configurable)
Output voltage terminal	0V output until module is configured \pm 10V (user configurable) 0...10V (user configurable) \pm 5V (user configurable) 0...5V (user configurable)
Step response to 63% of full scale	<25 μ s
Current load on voltage output, max	3 mA
Resistive load on voltage output	0...750 Ω
Absolute accuracy ⁽¹⁾ Voltage terminal Current terminal	0.1% full scale @ 25 °C 0.1% full scale @ 25 °C
Accuracy drift w/temperature Voltage terminal Current terminal	0.0028% full scale/°C 0.0038% full scale/°C

⁽¹⁾ Includes offset, gain, non-linearity and repeatability error terms.

Environmental Specifications

Attribute	Value
Temperature, operating	IEC 60068-2-1 (Test Ad, Operating Cold), IEC 60068-2-2 (Test Bd, Operating Dry Heat), IEC 60068-2-14 (Test Nb, Operating Thermal Shock): -20...55 °C (-4...131 °F)
Temperature, surrounding air, max.	55 °C (131 °F)
Temperature, nonoperating	IEC 60068-2-1 (Test Ab, Unpackaged Nonoperating Cold), IEC 60068-2-2 (Test Bb, Unpackaged Nonoperating Dry Heat), IEC 60068-2-14 (Test Na, Unpackaged Nonoperating Thermal Shock): -40...85 °C (-40...185 °F)
Relative humidity	IEC 60068-2-30 (Test Db, Unpackaged Damp Heat): 5...95% noncondensing
Vibration	IEC60068-2-6 (Test Fc, Operating): 5 g @ 10...500 Hz
Shock, operating	IEC60068-2-27 (Test Ea, Unpackaged shock): 30 g
Shock, nonoperating	IEC60068-2-27 (Test Ea, Unpackaged shock): 50 g
Emissions	CISPR 11: Group 1, Class A (with appropriate enclosure)
ESD immunity	IEC 61000-4-2: 6 kV contact discharges 8 kV air discharges
Radiated RF immunity	IEC 61000-4-3: 10V/m with 1 kHz sine-wave 80% AM from 80...2000 MHz 10V/m with 200 Hz 50% Pulse 100% AM @ 900 MHz 10V/m with 200 Hz 50% Pulse 100% AM @ 1890 MHz 3V/m with 1 kHz sine-wave 80% AM from 2000...2700 MHz
EFT/B immunity	IEC 61000-4-4: \pm 2 kV @ 5 kHz on power ports \pm 2 kV @ 5 kHz on shielded signal ports
Surge transient immunity	IEC 61000-4-5: \pm 1 kV line-line(DM) and \pm 2 kV line-earth(CM) on power ports \pm 2 kV line-earth(CM) on shielded signal ports
Conducted RF immunity	IEC 61000-4-6: 10V rms with 1 kHz sine-wave 80% AM from 150 kHz...80 MHz
Enclosure type rating	None (open-style)

Certifications (when product is marked)⁽¹⁾

Attribute	Value
c-UL-us	UL Listed Industrial Control Equipment, certified for US and Canada. See UL File E65584. UL Listed for Class I, Division 2 Group A,B,C,D Hazardous Locations, certified for U.S. and Canada. See UL File E194810.
CSA	CSA Certified Process Control Equipment. See CSA File LR54689C. CSA Certified Process Control Equipment for Class I, Division 2 Group A,B,C,D Hazardous Locations. See CSA File LR69960C.
Ex	European Union 94/9/EC ATEX Directive, compliant with: EN 60079-15; Potentially Explosive Atmospheres, Protection "n" EN 60079-0; General Requirements II 3 G Ex nA IIC T4 X
CE	European Union 2004/108/EC EMC Directive, compliant with: EN 61326-1; Meas./Control/Lab., Industrial Requirements EN 61000-6-2; Industrial Immunity EN 61000-6-4; Industrial Emissions EN 61131-2; Programmable Controllers (Clause 8, Zone A & B) European Union 2006/95/EC LVD, compliant with: EN 61131-2; Programmable Controllers (Clause 11)
C-Tick	Australian Radiocommunications Act compliant with: AS/NZS CISPR 11, Industrial Emissions
TÜV	TÜV Certified for Functional Safety ⁽²⁾ : Capable of SIL 2

⁽¹⁾ For the latest up-to-date information, see the Product Certification link at www.ab.com for Declarations of Conformity, Certificates and other certification details.

⁽²⁾ When used with specified firmware revisions.

Allen-Bradley, Rockwell Automation, FLEX, and TechConnect are trademarks of Rockwell Automation, Inc. Trademarks not belonging to Rockwell Automation are property of their respective companies.

Rockwell Otomasyon Ticaret A.Ş., Kar Plaza İş Merkezi E Blok Kat:6 34752 İçerenköy, İstanbul, Tel: +90 (216) 5698400

www.rockwellautomation.com

Power, Control and Information Solutions Headquarters

Americas: Rockwell Automation, 1201 South Second Street, Milwaukee, WI 53204-2496 USA, Tel: (1) 414.382.2000, Fax: (1) 414.382.4444

Europe/Middle East/Africa: Rockwell Automation, Vorstlaan/Boulevard du Souverain 36, 1170 Brussels, Belgium, Tel: (32) 2 663 0600, Fax: (32) 2 663 0640

Asia Pacific: Rockwell Automation, Level 14, Core F, Cyberport 3, 100 Cyberport Road, Hong Kong, Tel: (852) 2887 4788, Fax: (852) 2508 1846

Publication 1794-IN039F-EN-P - November 2011

Supersedes publication 1794-IN039E-EN-P - August 2005

PN-126017

Copyright © 2011 Rockwell Automation, Inc. All rights reserved.