



FLEX I/O Digital Input and Output Modules with Diagnostics

Catalog numbers 1794-IB16D, 1794-OB16D

Table of Contents

Topic	Page
Important User Information	2
Environment and Enclosure	3
Preventing Electrostatic Discharge	3
North American Hazardous Location Approval	6
Install the Isolated Analog Output Module	7
Diagnostics	11
Configuration	14
Specifications	16

Important User Information

Solid-state equipment has operational characteristics differing from those of electromechanical equipment. Safety Guidelines for the Application, Installation, and Maintenance of Solid-State Controls (Publication [SGI-1.1](#) available from your local Rockwell Automation Sales Office or online at <http://www.rockwellautomation.com/literature/>) describes some important differences between solid-state equipment and hard-wired electromechanical devices. Because of this difference, and also because of the wide variety of uses for solid-state equipment, all persons responsible for applying this equipment must satisfy themselves that each intended application of this equipment is acceptable.

In no event will Rockwell Automation, Inc. be responsible or liable for indirect or consequential damages resulting from the use or application of this equipment.

The examples and diagrams in this manual are included solely for illustrative purposes. Because of the many variables and requirements associated with any particular installation, Rockwell Automation, Inc. cannot assume responsibility or liability for actual use based on the examples and diagrams.

No patent liability is assumed by Rockwell Automation, Inc. with respect to use of information, circuits, equipment, or software described in this manual.

Reproduction of the contents of this manual, in whole or in part, without written permission of Rockwell Automation, Inc., is prohibited.

Throughout this manual, when necessary, we use notes to make you aware of safety considerations.



WARNING: Identifies information about practices or circumstances that can cause an explosion in a hazardous environment, which may lead to personal injury or death, property damage, or economic loss.



ATTENTION: Identifies information about practices or circumstances that can lead to personal injury or death, property damage, or economic loss. Attentions help you identify a hazard, avoid a hazard, and recognize the consequences.

IMPORTANT

Identifies information that is critical for successful application and understanding of the product.

Environment and Enclosure



ATTENTION: This equipment is intended for use in a Pollution Degree 2 industrial environment, in overvoltage Category II applications (as defined in EN/IEC 60664-1), at altitudes up to 2000 m (6562 ft) without derating.

This equipment is not intended for use in residential environments and may not provide adequate protection to radio communication services in such environments.

This equipment is supplied as open-type equipment for indoor use. It must be mounted within an enclosure that is suitably designed for those specific environmental conditions that will be present and appropriately designed to prevent personal injury resulting from accessibility to live parts. The enclosure must have suitable flame-retardant properties to prevent or minimize the spread of flame, complying with a flame spread rating of 5VA or be approved for the application if nonmetallic. The interior of the enclosure must be accessible only by the use of a tool. Subsequent sections of this publication may contain more information regarding specific enclosure type ratings that are required to comply with certain product safety certifications.

In addition to this publication, see the following:

- Industrial Automation Wiring and Grounding Guidelines, Rockwell Automation publication [1770-4.1](#), for more installation requirements.
- NEMA Standard 250 and EN/IEC 60529, as applicable, for explanations of the degrees of protection provided by enclosures.

Preventing Electrostatic Discharge



ATTENTION: This equipment is sensitive to electrostatic discharge, which can cause internal damage and affect normal operation. Follow these guidelines when you handle this equipment:

- Touch a grounded object to discharge potential static.
 - Wear an approved grounding wriststrap.
 - Do not touch connectors or pins on component boards.
 - Do not touch circuit components inside the equipment.
 - Use a static-safe workstation, if available.
 - Store the equipment in appropriate static-safe packaging when not in use.
-

4 FLEX I/O Digital Input and Output Modules with Diagnostics



ATTENTION: This product is grounded through the DIN rail to chassis ground. Use zinc plated chromate-passivated steel DIN rail to assure proper grounding. The use of other DIN rail materials (for example, aluminum or plastic) that can corrode, oxidize, or are poor conductors, can result in improper or intermittent grounding. Secure DIN rail to mounting surface approximately every 200 mm (7.8 in.) and use end-anchors appropriately. Be sure to ground the DIN rail properly.

Refer to Industrial Automation Wiring and Grounding Guidelines, Rockwell Automation publication [1770-4.1](#), for more information



ATTENTION: If this equipment is used in a manner not specified by the manufacturer, the protection provided by the equipment may be impaired.



ATTENTION: If this equipment is used in a manner not specified by the manufacturer, the protection provided by the equipment may be impaired.

ATTENTION: Read this document and the documents listed in the Additional Resources section about installation, configuration, and operation of this equipment before you install, configure, operate, or maintain this product. Users are required to familiarize themselves with installation and wiring instructions in addition to requirements of all applicable codes, laws, and standards.

ATTENTION: Installation, adjustments, putting into service, use, assembly, disassembly, and maintenance are required to be carried out by suitably trained personnel in accordance with applicable code of practice.

ATTENTION: In case of malfunction or damage, no attempts at repair should be made. The module should be returned to the manufacturer for repair. Do not dismantle the module.

ATTENTION: Use only a soft dry anti-static cloth to wipe down equipment. Do not use any cleaning agents.



WARNING: When you insert or remove the module while backplane power is on, an electric arc can occur. This could cause an explosion in hazardous location installations.

Be sure that power is removed or the area is nonhazardous before proceeding. Repeated electric arcing causes excessive wear to contacts on both the module and its mating connector. Worn contacts may create electrical resistance that can affect module operation.





WARNING: If you insert or remove the module while backplane power is on, an electric arc can occur. This could cause an explosion in hazardous location installations.

Be sure that power is removed or the area is nonhazardous before proceeding.

North American Hazardous Location Approval

The following modules are North American Hazardous Location approved: 1794-IB16D, 1794-OB16D.

The following information applies when operating this equipment in hazardous locations:	Informations sur l'utilisation de cet équipement en environnements dangereux:
<p>Products marked "CL I, DIV 2, GP A, B, C, D" are suitable for use in Class I Division 2 Groups A, B, C, D, Hazardous Locations and nonhazardous locations only. Each product is supplied with markings on the rating nameplate indicating the hazardous location temperature code. When combining products within a system, the most adverse temperature code (lowest "T" number) may be used to help determine the overall temperature code of the system. Combinations of equipment in your system are subject to investigation by the local Authority Having Jurisdiction at the time of installation.</p>	<p>Les produits marqués "CL I, DIV 2, GP A, B, C, D" ne conviennent qu'à une utilisation en environnements de Classe I Division 2 Groupes A, B, C, D dangereux et non dangereux. Chaque produit est livré avec des marquages sur sa plaque d'identification qui indiquent le code de température pour les environnements dangereux. Lorsque plusieurs produits sont combinés dans un système, le code de température le plus défavorable (code de température le plus faible) peut être utilisé pour déterminer le code de température global du système. Les combinaisons d'équipements dans le système sont sujettes à inspection par les autorités locales qualifiées au moment de l'installation.</p>
<div style="display: flex; align-items: center;">  <div> <p>WARNING: Explosion Hazard</p> <ul style="list-style-type: none"> • Do not disconnect equipment unless power has been removed or the area is known to be nonhazardous. • Do not disconnect connections to this equipment unless power has been removed or the area is known to be nonhazardous. Secure any external connections that mate to this equipment by using screws, sliding latches, threaded connectors, or other means provided with this product. • Substitution of components may impair suitability for Class I, Division 2. </div> </div>	<div style="display: flex; align-items: center;">  <div> <p>AVERTISSEMENT: Risque d'Explosion</p> <ul style="list-style-type: none"> • Couper le courant ou s'assurer que l'environnement est classé non dangereux avant de débrancher l'équipement. • Couper le courant ou s'assurer que l'environnement est classé non dangereux avant de débrancher les connecteurs. Fixer tous les connecteurs externes reliés à cet équipement à l'aide de vis, loquets coulissants, connecteurs filetés ou autres moyens fournis avec ce produit. • La substitution de composants peut rendre cet équipement inadapté à une utilisation en environnement de Classe I, Division 2. </div> </div>

Install the Isolated Analog Output Module

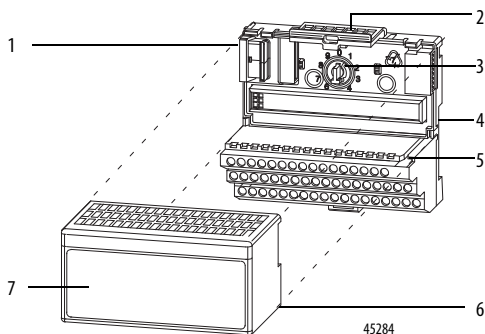

Component Identification

	Description		Description
1	Flexbus connectors	5	Groove
2	Latching mechanism	6	Alignment bar
3	Keyswitch	7	Module
4	Terminal base		

The input module mounts on a 1794-TB32 or 1794-TB32S terminal base. The output module mounts on a 1794-TB2, 1794-TB3, or 1794-TB3S terminal base.

1. Rotate the keyswitch (3) on the terminal base (4) clockwise to position 4 as required for this type of module.
2. Make sure the Flexbus connector (1) is pushed all the way to the left to connect with the neighboring terminal base/adapter.
You cannot install the module unless the connector is fully extended.
3. Make sure the pins on the bottom of the module are straight so they will align properly with the connector in the terminal base.
4. Position the module (7) with its alignment bar (6) aligned with the groove (5) on the terminal base.
5. Press firmly and evenly to seat the module in the terminal base unit. The module is seated when the latching mechanism (2) is locked into the module.

1794-TB32 and 1794-TB32S Terminal Base Wiring for 1794-IB16D

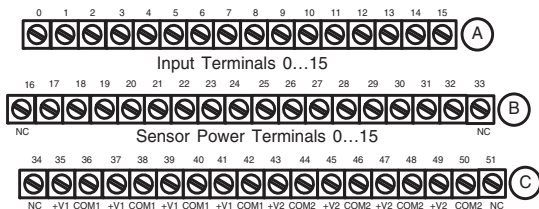

+V2 = Terminals 43, 45, 47 and 49 -

Voltage applied to Inputs 0...15 and Sensor power 0...15

COM1, COM2 = Terminals 36, 38, 40, 42, 44, 46, 48 and 50 -

Common for inputs 0...15 and sensor power 0...15

NC = No connections (terminals 16, 33, 34 and 51)

+V1 = Terminals 35, 37, 39 and 41 (not used)

Wiring Connections for the 1794-IB16 Module

(use with 1794-TB32 or 1794-TB32S terminal base units)

Input	Input Terminal	Sensor Power Terminal	Common	Supply ⁽¹⁾
IN 00	A-0	B-17	-V common connected to terminals 36, 38, 40, 42, 44, 46, 48, and 50	+V2 connected to terminals 43, 45, 47, and 49
IN 01	A-1	B-18		
IN 02	A-2	B-19		
IN 03	A-3	B-20		
IN 04	A-4	B-21		
IN 05	A-5	B-22		
IN 06	A-6	B-23		
IN 07	A-7	B-24		
IN 08	A-8	B-25		
IN 09	A-9	B-26		
IN 10	A-10	B-27		
IN 11	A-11	B-28		
IN 12	A-12	B-29		
IN 13	A-13	B-30		
IN 14	A-14	B-31		
IN 15	A-15	B-32		
+V2 DC power	Power terminals 43, 45, 47 and 49 (power terminals are internally connected together in the module)			
COM DC return	Common terminals 36, 38, 40, 42, 44, 46, 48 and 50 (common terminals are internally connected together in the module)			

⁽¹⁾ 3-wire devices only. 2-wire devices use input and sensor power terminals; 3-wire devices use input, sensor power and common terminals.



ATTENTION: Do not remove or replace a Terminal Base unit while power is applied. Interruption of the backplane can result in unintentional operation or machine motion.

Connecting Wiring for the 1794-OB16D Module

use with 1794-TB2, 1794-TB3, or 1794-TB3S Terminal Base

1. Connect individual output wiring to numbered terminals on the 0-15 row (A) as indicated in the Wiring Connections for 1794-OB16D table.
2. Connect the associated common for each output to the corresponding terminal on the 16-33 row (B) as indicated in the Wiring Connections for 1794-OB16D table. The common terminals of row (B) are internally connected together.
3. Connect +V DC power to terminal 34 on the 34-51 row (C). The power terminals of row (C) are internally connected together.
4. Connect DC common (COM) to terminal 16 on the 16-33 row (B).
5. If daisychaining power to the next terminal base, connect a jumper from terminal 51 (+V DC) on this base unit to terminal 34 on the next base unit.
6. If continuing DC common to the next base unit, connect a jumper from terminal 33 (common) on this base unit to terminal 16 on the next base unit.

1794-TB32 and 1794-TB32S Terminal Base Wiring for 1794-OB16D

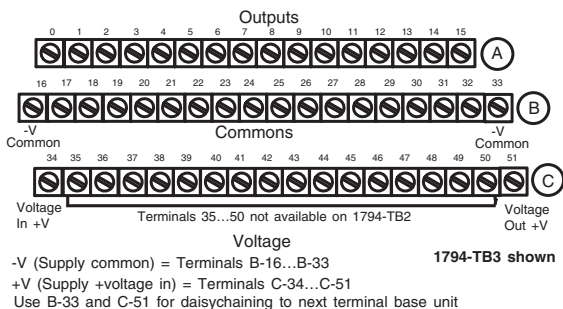

Wiring Connections for the 1794-OB16D Output Module

use with 1794-TB2, 1794-TB3, or 1794-TB3S terminal base

Output	Output Terminal	Common Terminal
Output 00	A-0	B-17
Output 01	A-1	B-18
Output 02	A-2	B-19
Output 03	A-3	B-20
Output 04	A-4	B-21
Output 05	A-5	B-22
Output 06	A-6	B-23
Output 07	A-7	B-24
Output 08	A-8	B-25
Output 09	A-9	B-26
Output 10	A-10	B-27
Output 11	A-11	B-28
Output 12	A-12	B-29
Output 13	A-13	B-30
Output 14	A-14	B-31
Output 15	A-15	B-32
-V DC	C-34 and C-51 (1794-TB2). Power Terminals are internally connected in the terminal base unit. C-34...C-51 (1794-TB3, 1794-TB3S). Power terminals are internally connected in the terminal base unit.	
Common	B-16...B-33. Common terminals are internally connected in the terminal base unit.	

Diagnostics

See configuration information below for location of diagnostic bits.

Note: Each unused sensor port requires a dummy resistor to mask the channel diagnostic function.

Diagnostic Functions for the 1794-IB16D

Ext. Power	Wiring	Input Status	Channel LED Status	Open Wire Error Bit	Short Error Bit	Rev. Error Bit	Module Error Bit/LED
OFF	Open	Off	Off	0	0	0	0/OFF
		On	Off	0	0	0	0/OFF
	Short	Off	Off	0	0	0	0/OFF
		On	Off	0	0	0	0/OFF
	Normal	Off	Off	0	0	0	0/OFF
		On	Off	0	0	0	0/OFF
ON	Open	Off	RED	1	0	0	1/RED
		On	RED/YEL	1	0	0	1/RED
	Short	Off	RED	0	1	0	1/RED
		On	RED/YEL	0	1	0	1/RED
	Normal	Off	Off	0	0	0	0/OFF
		On	YEL	0	0	0	0/OFF
REV	Open	Off	Off	0	0	1	1/RED
		On	Off	0	0	1	1/RED
	Short	Off	Off	0	0	1	1/RED
		On	Off	0	0	1	1/RED
	Normal	Off	Off	0	0	1	1/RED
		On	Off	0	0	1	1/RED

The module monitors each sensor-power port for current and voltage. It turns on the channel red LED and sets (1) the error bit when 1) the module detects a short circuit (no voltage at the sensor-port), and 2) the module detects an open wire (no current at the sensor-port).

Diagnostic Functions for the 1794-OB16D

Ext. Power	Wiring	Input Status	Channel LED Status	Open Wire Error Bit	Short Error Bit	Rev. Error Bit	Module Error Bit/LED
OFF	Open	Off	Off	0	0	0	0/OFF
		On	Off	0	0	0	0/OFF
	Short	Off	Off	0	0	0	0/OFF
		On	Off	0	0	0	0/OFF
	Normal	Off	Off	0	0	0	0/OFF
		On	Off	0	0	0	0/OFF
ON	Open	Off	RED	1	0	0	1/RED
		On	YEL	0	0	0	0/OFF
	Short	Off	Off	0	0	0	0/OFF
		On	RED	0	1	0	1/RED
	Normal	Off	Off	0	0	0	0/OFF
		On	YEL	0	0	0	0/OFF
REV	Open	Off	Off	0	0	1	1/RED
		On	Off	0	0	1	1/RED
	Short	Off	Off	0	0	1	1/RED
		On	Off	0	0	1	1/RED
	Normal	Off	Off	0	0	1	1/RED
		On	Off	0	0	1	1/RED

The module monitors each output channel. It turns on the channel red LED and sets (1) the error bit when 1) the module detects a short circuit (the output signal is active at a channel and the corresponding output voltage is low), and 2) the module detects an open wire (the output signal is inactive at a channel and the corresponding output voltage is high).

Sensor Diagram for the 1794-IB16D Module

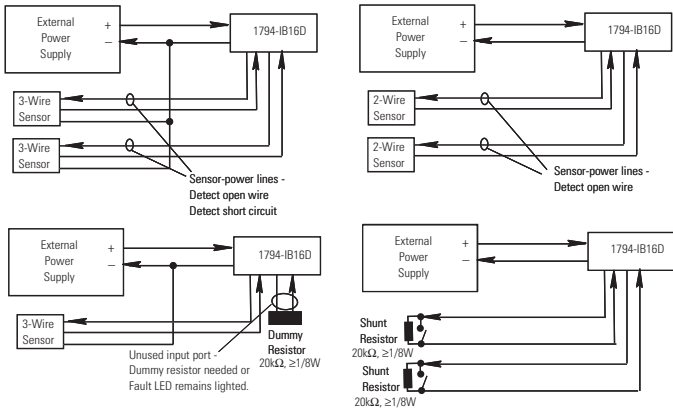

Sensor Diagram for the 1794-OB16D Module

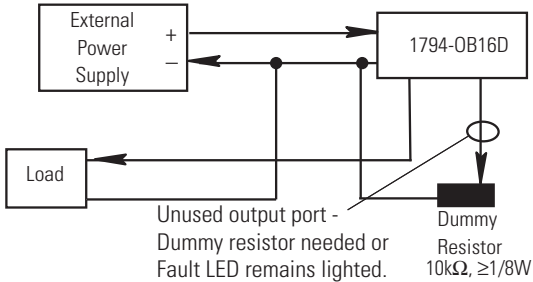

Configuration

Configuring Your 1794-IB16D Input Module

Configure your input module by setting bits in the configuration word (word 3). This module is compatible with the Remote I/O network with 1794-ASB series E or later, DeviceNet network, and the ControlNet network. Note: You must use the Module Connection when used in a ControlNet system

Image Table Memory Map for the 1794-IB16D Module

Dec	15	14	13	12	11	10	9	8	7	6	5	4	3	2	1	0
Oct	17	16	15	14	13	12	11	10	7	6	5	4	3	2	1	0
Read 1	I15	I14	I13	I12	I11	I10	I9	I8	I7	I6	I5	I4	I3	I2	I1	I0
Read 2													Read Diagnostic Status			
Write 3	Not Used					Input Filter FT 0...15			Not Used							

Where I = Input status
FT = Filter Time

Diagnostic Status
Bit 00 = Module error;
Bit 01 = External power reverse polarity error;
Bit 02 = Sensor power short error;
Bit 03 = Sensor power open wire error



At the end of its life, this equipment should be collected separately from any unsorted municipal waste.

Setting the Input Filter Time

To set the input filter time, set the associated bits in the output image (complementary word) for the module.

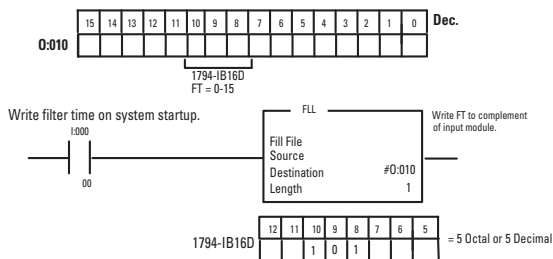

Input Filter Time

Bits			Description	Filter Time
10	09	08	Filter Time for inputs 0...15	Off to On / On to Off
0	0	0	Filter Time 0 (Default)	0.25 ms
0	0	1	Filter Time 1	0.5 ms
0	1	0	Filter Time 2	1 ms
0	1	1	Filter Time 3	2 ms
1	0	1	Filter Time 4	4 ms
1	0	1	Filter Time 5	8 ms
1	1	0	Filter Time 6	16 ms
1	1	1	Filter Time 7	32 ms

Configuring Your 1794-OB16D Output Module

Configure your output module by setting bits in the configuration word (word 3). This module is compatibility with the Remote I/O network, with 1794-ASB series D or later,

16 FLEX I/O Digital Input and Output Modules with Diagnostics

DeviceNet network, and the ControlNet network. Note: You can use the Module Connection or Rack Connection when used in a ControlNet system.

Image Table Memory Map for the 1794-0B16D Module

Dec	15	14	13	12	11	10	9	8	7	6	5	4	3	2	1	0
Oct	17	16	15	14	13	12	11	10	7	6	5	4	3	2	1	0
Read 1	Not used												Read Diagnostic Status			
Write 2	015	014	013	012	011	010	09	08	07	06	05	04	03	02	01	00

Where O = Output

Diagnostic Status
Bit 00 = Module error;
Bit 01 = External power reverse polarity error;
Bit 02 = Output short error;
Bit 03 = Output open wire error

Specifications

Specifications – 16 Input Module w/ Diagnostics, 1794-IB16D

Meets IEC 3 24V DC input specifications

Attribute	Value
Number of inputs	16, current, sinking
Recommended terminal base unit	1794-TB32, 1794-TB32S, 1794-TB62DS, 1794-TB62EXD4X15
On-state voltage, min	10V DC
On-state voltage, nom	24V DC
On-state voltage, max	31.2V DC
On-state current, min	2.0 mA
On-state current, max	1.5 mA
Off-state voltage, max	5.0V DC
Off-state current, max	1.5 mA
Nominal input impedance	3.1 k Ω
Isolation voltage	50V (continuous), Basic Insulation Type Type tested @ 2121V DC for 2 s, between field side and system No isolation between individual channels
Input filter time ⁽¹⁾ Off to On On to Off	Refer to Setting the Input Filter Time table.

Specifications – 16 Input Module w/ Diagnostics, 1794-IB16D

Meets IEC 3 24V DC input specifications

Attribute	Value
Flexbus current	30 mA @ 5V DC
Power dissipation, max	8.5 W @ 31.2V DC
Thermal dissipation, max	29 BTU/hr @ 31.2V DC
Sensor power, voltage drop, max	2.2V DC
Sensor power, current, max	50 mA
Sensor power line, short detect circuit, min	1.0 A (in 10 s)
Sensor power line, open wire detect, max	50 μ A
Detect reverse polarity voltage	Minimum 10V: Module must detect if the reverse polarity external power supply voltage is greater than the value.

⁽¹⁾ Input off-to-on filter time is the time from a valid input signal to recognition by the module. Input on-to-off filter time is time from the input signal dropping below the valid level to recognition by the module.

Specifications – 16 Output Module w/ Diagnostics, 1794-OB16D

Attribute	Value
Number of outputs	16, current, sourcing
Recommended terminal base unit	1794-TB2, 1794-TB3, 1794-TB3S
Output voltage, min	10V DC
Output voltage, nom	24V DC
Output voltage, max	31.2V DC
Output current rating	8.0 A (16 outputs @ 0.5 A)
On-state current, min	1.0 mA per channel
On-state current, max	500 mA per channel
Surge current	2 A for 50 ms each, repeatable every 2 seconds
Off-state leakage, max	0.5 mA
Isolation voltage	50V (continuous), Basic Insulation Type Type tested at 850V DC for 60 s, between field side and system No isolation between individual channels
Output signal delay ⁽¹⁾ Off to On On to Off	0.5 ms 0.5 ms

Specifications – 16 Output Module w/ Diagnostics, 1794-OB16D

Attribute	Value
FlexBus current	60 mA @ 5V DC
Power dissipation, max	4.8 W @ 31.2V DC
Thermal dissipation, max	16.4 BTU/hr @ 31.2V DC
Short circuit protect and detection	Thermal shutdown (auto reset) Detection condition: when external power active, output signal active, and output port voltage less than 2V.
Open wire detect off-state leakage current	0.1 mA – When external power active and output signal inactive.
Detect reverse polarity voltage	Minimum 10V: Module must detect if the reverse polarity external power supply voltage is greater than the value.

⁽¹⁾ Delay time is the time from the receipt of an output on or off command to the output actually turning on or off.

General Specifications

Attribute	Value
Terminal base screw torque	Determined by installed terminal base
Dimensions, approx. (H x W x D)	45.7 x 94 x 53.3 mm (1.8 x 3.7 x 2.1 in.) – 1794-IB16D 94 x 94 x 91 mm (3.7 x 3.7 x 3.6 in.) – 1794-OB16D
Weight, approx.	90 g (3.17 oz.) – 1794-IB16D 95 g (3.35 oz.) – 1794-OB16D
Indicators (field side)	16 yellow ON/OFF status indicators 16 red diagnostic status indicators 1 red module fault indicator
External DC power supply voltage, nom	24V DC
External DC power voltage range	10...31.2V DC (includes 5% AC ripple)
North American temp code	T3C
Keyswitch position	2
Enclosure type rating	None (open-style)
Wire size	Determined by installed terminal base
Wiring category ⁽¹⁾	2 - on signal ports

⁽¹⁾ Use this conductor category information for planning conductor routing as described in Industrial Automation Wiring and Grounding Guidelines, publication [1770-4.1](#).

Environmental Specifications

Attribute	Value
Operating temperature	IEC 60068-2-1 (Test Ad, Operating Cold), IEC 60068-2-2 (Test Bd, Operating Dry Heat), IEC 60068-2-14 (Test Nb, Operating Thermal Shock): 0 °C < Ta < +55 °C (+32 °F < Ta < +131 °F)
Temperature, surrounding air, max.	55 °C (131 °F)
Storage temperature	IEC 60068-2-1 (Test Ab, Unpackaged Non-operating Cold), IEC 60068-2-2 (Test Bb, Unpackaged Non-operating Dry Heat), IEC 60068-2-14 (Test Na, Unpackaged Non-operating Thermal Shock): -40...85 °C (-40...185 °F)
Relative humidity	IEC 60068-2-30 (Test Db, Unpackaged Damp Heat): 5...95% non-condensing
Vibration	IEC60068-2-6 (Test Fc, Operating): 5 g @ 10...500 Hz
Shock, operating	IEC60068-2-27 (Test Ea, Unpackaged shock): 30 g
Shock, nonoperating	IEC60068-2-27 (Test Ea, Unpackaged shock): 50 g
Emissions	CISPR 11: Group 1, Class A (with appropriate enclosure)
ESD immunity	IEC 61000-4-2: 6 kV contact discharges 8 kV air discharges
Radiated RF immunity	IEC 61000-4-3: 10V/m with 1 kHz sine-wave 80% AM from 80...2000 MHz 10V/m with 200 Hz 50% Pulse 100% AM @ 900 MHz 10V/m with 200 Hz 50% Pulse 100% AM @ 1890 MHz 1V/m with 1 kHz sine-wave 80% AM from 2000...2700 MHz
EFT/B immunity	IEC 61000-4-4: ±2 kV @ 5 kHz on power ports ±2 kV @ 5 kHz on signal ports
Surge transient immunity	IEC 61000-4-5: ±1 kV line-line(DM) and ±2 kV line-earth(CM) on signal ports
Conducted RF immunity	IEC 61000-4-6: 10V rms with 1 kHz sine-wave 80% AM from 150 kHz...80 MHz

Certifications

Certifications (when product is marked) ⁽¹⁾	Value
c-UL-us	UL Listed Industrial Control Equipment, certified for US and Canada. See UL File E322657. UL Listed for Class I, Division 2 Group A,B,C,D Hazardous Locations, certified for U.S. and Canada. See UL File E334470.
CE	European Union 2014/30/EU EMC Directive, compliant with: EN 61131-2; Programmable Controllers (Clause 11) EN 61000-6-2; Industrial Immunity EN 61000-6-4; Industrial Emissions EN 61131-2; Programmable Controllers (Clause 8, Zone A & B) European Union 2011/65/EU RoHS, compliant with: EN 50581; Technical documentation
KC	Korean Registration of Broadcasting and Communications Equipment, compliant with: Article 58-2 of Radio Waves Act, Clause 3
EAC	Russian Customs Union TR CU 020/2011 EMC Technical Regulation
RCM	Australian Radiocommunications Act, compliant with: AS/NZS CISPR 11; Industrial Emissions

⁽¹⁾ See the Product Certification link at <http://www.rockwellautomation.com/global/certification/overview.page> for Declarations of Conformity, Certificates, and other certification details.

Derating Curves

1794-IB16D Input Voltage

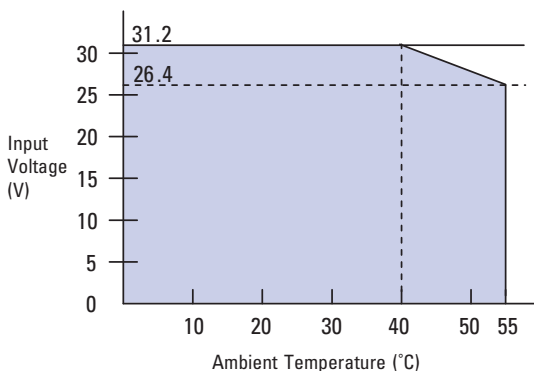

Sensor Power

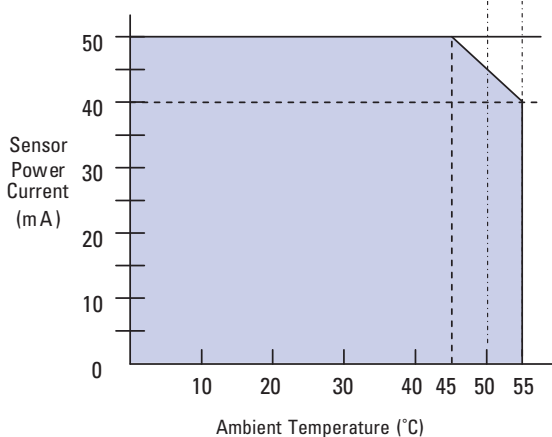

WARNING: When used in a Class I, Division 2, hazardous location, this equipment must be mounted in a suitable enclosure with proper wiring method that complies with the governing electrical codes.

Notes:

Notes:

Rockwell Automation Support

Rockwell Automation provides technical information on the Web to assist you in using its products. At <http://www.rockwellautomation.com/support/>, you can find technical manuals, a knowledge base of FAQs, technical and application notes, sample code and links to software service packs, and a MySupport feature that you can customize to make the best use of these tools.

For an additional level of technical phone support for installation, configuration and troubleshooting, we offer TechConnect support programs. For more information, contact your local distributor or Rockwell Automation representative, or visit <http://www.rockwellautomation.com/support/>.

Installation Assistance

If you experience a problem within the first 24 hours of installation, please review the information that's contained in this manual. You can also contact a special Customer Support number for initial help in getting your product up and running.

United States or Canada	1.440.646.3434
Outside United States or Canada	Use the Worldwide Locator at http://www.rockwellautomation.com/support/americas/phone_en.html , or contact your local Rockwell Automation representative.

New Product Satisfaction Return

Rockwell Automation tests all of its products to ensure that they are fully operational when shipped from the manufacturing facility. However, if your product is not functioning and needs to be returned, follow these procedures.

United States	Contact your distributor. You must provide a Customer Support case number (call the phone number above to obtain one) to your distributor to complete the return process.
Outside United States	Please contact your local Rockwell Automation representative for the return procedure.

Documentation Feedback

Your comments will help us serve your documentation needs better. If you have any suggestions on how to improve this document, complete this form, publication [RA-DU002](#), available at <http://www.rockwellautomation.com/literature/>.

Allen-Bradley, Rockwell Automation, FLEX I/O, Rockwell Software, and TechConnect are trademarks of Rockwell Automation, Inc.

Trademarks not belonging to Rockwell Automation are property of their respective companies.

Rockwell Otomasyon Ticaret A.Ş., Kar Plaza İş Merkezi E Blok Kat:6 34752 İçerenköy, İstanbul, Tel: +90 (216) 5698400

www.rockwellautomation.com

Power, Control and Information Solutions Headquarters

Americas: Rockwell Automation, 1201 South Second Street, Milwaukee, WI 53204-2496 USA, Tel: (1) 414.382.2000, Fax: (1) 414.382.4444
Europe/Middle East/Africa: Rockwell Automation NV, Pegasus Park, De Kleeflaan 12a, 1831 Diegem, Belgium, Tel: (32) 2 663 0600, Fax: (32) 2 663 0640
Asia Pacific: Rockwell Automation, Level 14, Core F, Cyberport 3, 100 Cyberport Road, Hong Kong, Tel: (852) 2887 4788, Fax: (852) 2508 1846

Publication 1794-IN096D-EN-P - June 2018

Supersedes Publication 1794-IN096C-EN-P - August 2015

Copyright © 2018 Rockwell Automation, Inc. All rights reserved.