

# Installation Instructions

Original Instructions



**Allen-Bradley**

by ROCKWELL AUTOMATION

## POINT I/O DeviceNet Communication Interface Module

Catalog Numbers 1734-PDN, 1734-PDNK, Series B

| Topic                                      | Page |
|--|------|
| Important User Information                 | 2    |
| Environment and Enclosure                  | 3    |
| Preventing Electrostatic Discharge         | 4    |
| North American Hazardous Location Approval | 4    |
| European Hazardous Location Approval       | 5    |
| Identify Module Components                 | 6    |
| Install the Module                         | 7    |
| Install the Module in an Existing System   | 8    |
| Wire the Module                            | 9    |
| Troubleshoot with Indicators               | 12   |
| Specifications                             | 13   |

### Summary of Changes

This publication contains the following new or updated information. This list includes substantive updates only and is not intended to reflect all changes.

| Topic  | Page       |
|--|------------|
| Added catalog 1734-PDNK.                                 | 1          |
| Updated environmental specifications and certifications. | Throughout |



**Rockwell  
Automation**

## Important User Information

Solid-state equipment has operational characteristics differing from those of electromechanical equipment. Safety Guidelines for the Application, Installation and Maintenance of Solid State Controls (Publication [SGI-1.1](#) available from your local Rockwell Automation sales office or online at <http://www.rockwellautomation.com/literature/>) describes some important differences between solid-state equipment and hard-wired electromechanical devices. Because of this difference, and also because of the wide variety of uses for solid-state equipment, all persons responsible for applying this equipment must satisfy themselves that each intended application of this equipment is acceptable.





In no event will Rockwell Automation, Inc. be responsible or liable for indirect or consequential damages resulting from the use or application of this equipment.

The examples and diagrams in this manual are included solely for illustrative purposes. Because of the many variables and requirements associated with any particular installation, Rockwell Automation, Inc. cannot assume responsibility or liability for actual use based on the examples and diagrams.

No patent liability is assumed by Rockwell Automation, Inc. with respect to use of information, circuits, equipment, or software described in this manual.

Reproduction of the contents of this manual, in whole or in part, without written permission of Rockwell Automation, Inc., is prohibited.

Throughout this manual, when necessary, we use notes to make you aware of safety considerations.

|  |  |
|--|--|
|    | <p><b>WARNING:</b> Identifies information about practices or circumstances that can cause an explosion in a hazardous environment, which may lead to personal injury or death, property damage, or economic loss.</p>                                |
|    | <p><b>ATTENTION:</b> Identifies information about practices or circumstances that can lead to personal injury or death, property damage, or economic loss. Attentions help you identify a hazard, avoid a hazard and recognize the consequences.</p> |
|  | <p><b>SHOCK HAZARD:</b> Labels may be on or inside the equipment (for example, drive or motor) to alert people that dangerous voltage may be present.</p>  |
|  | <p><b>BURN HAZARD:</b> Labels may be on or inside the equipment (for example, drive or motor) to alert people that surfaces may reach dangerous temperatures.</p>  |
| <p><b>IMPORTANT</b></p>  | <p>Identifies information that is critical for successful application and understanding of the product.</p>  |

## Environment and Enclosure



**ATTENTION:** This equipment is intended for use in a Pollution Degree 2 industrial environment, in overvoltage Category II applications (as defined in EN/IEC 60664-1), at altitudes up to 2000 m (6562 ft) without derating.

This equipment is not intended for use in residential environments and may not provide adequate protection to radio communication services in such environments.

This equipment is considered Group 1, Class A industrial equipment according to IEC/CISPR Publication 11. Without appropriate precautions, there may be potential difficulties ensuring electromagnetic compatibility in other environments due to conducted as well as radiated disturbance.

This equipment is supplied as open-type equipment for indoor use. It must be mounted within an enclosure that is suitably designed for those specific environmental conditions that will be present and appropriately designed to prevent personal injury resulting from accessibility to live parts. The enclosure must have suitable flame-retardant properties to prevent or minimize the spread of flame, complying with a flame spread rating of 5VA or be approved for the application if nonmetallic. The interior of the enclosure must be accessible only by the use of a tool. Subsequent sections of this publication may contain more information regarding specific enclosure type ratings that are required to comply with certain product safety certifications.

In addition to this publication, see:

- Industrial Automation Wiring and Grounding Guidelines, publication [1770-4.1](#), for more installation requirements.
- NEMA Standard 250 and EN/IEC 60529, as applicable, for explanations of the degrees of protection provided by enclosures.



**ATTENTION:** This product is grounded through the DIN rail to chassis ground. Use zinc plated yellow-chromate steel DIN rail to assure proper grounding. The use of other DIN rail materials (for example, aluminum or plastic) that can corrode, oxidize, or are poor conductors, can result in improper or intermittent grounding. Secure DIN rail to mounting surface approximately every 200 mm (7.8 in.) and use end-anchors appropriately.

## Preventing Electrostatic Discharge



**ATTENTION:** This equipment is sensitive to electrostatic discharge, which can cause internal damage and affect normal operation. Follow these guidelines when you handle this equipment:

- Touch a grounded object to discharge potential static.
- Wear an approved grounding wriststrap.
- Do not touch connectors or pins on component boards.
- Do not touch circuit components inside the equipment.
- Use a static-safe workstation, if available.
- Store the equipment in appropriate static-safe packaging when not in use.

## North American Hazardous Location Approval

### The following information applies when operating this equipment in hazardous locations:

Products marked "CL I, DIV 2, GP A, B, C, D" are suitable for use in Class I Division 2 Groups A, B, C, D, Hazardous Locations and nonhazardous locations only. Each product is supplied with markings on the rating nameplate indicating the hazardous location temperature code. When combining products within a system, the most adverse temperature code (lowest "T" number) may be used to help determine the overall temperature code of the system. Combinations of equipment in your system are subject to investigation by the local Authority Having Jurisdiction at the time of installation.

### Informations sur l'utilisation de cet équipement en environnements dangereux:

Les produits marqués "CL I, DIV 2, GP A, B, C, D" ne conviennent qu'à une utilisation en environnements de Classe I Division 2 Groupes A, B, C, D dangereux et non dangereux. Chaque produit est livré avec des marquages sur sa plaque d'identification qui indiquent le code de température pour les environnements dangereux. Lorsque plusieurs produits sont combinés dans un système, le code de température le plus défavorable (code de température le plus faible) peut être utilisé pour déterminer le code de température global du système. Les combinaisons d'équipements dans le système sont sujettes à inspection par les autorités locales qualifiées au moment de l'installation.



#### EXPLOSION HAZARD

- Do not disconnect equipment unless power has been removed or the area is known to be nonhazardous.
- Do not disconnect connections to this equipment unless power has been removed or the area is known to be nonhazardous. Secure any external connections that mate to this equipment by using screws, sliding latches, threaded connectors, or other means provided with this product.
- Substitution of components may impair suitability for Class I, Division 2.
- If this product contains batteries, they must only be changed in an area known to be nonhazardous.



#### RISQUE D'EXPLOSION

- Couper le courant ou s'assurer que l'environnement est classé non dangereux avant de débrancher l'équipement.
- Couper le courant ou s'assurer que l'environnement est classé non dangereux avant de débrancher les connecteurs. Fixer tous les connecteurs externes reliés à cet équipement à l'aide de vis, loquets coulissants, connecteurs filetés ou autres moyens fournis avec ce produit.
- La substitution de composants peut rendre cet équipement inadapté à une utilisation en environnement de Classe I, Division 2.
- S'assurer que l'environnement est classé non dangereux avant de changer les piles.

## European Hazardous Location Approval

The following applies to products marked **CE** **Ex** **II 3 G**:

- Are intended for use in potentially explosive atmospheres as defined by European Union Directive 2014/34/EU and has been found to comply with the Essential Health and Safety Requirements relating to the design and construction of Category 3 equipment intended for use in Zone 2 potentially explosive atmospheres, given in Annex II to this Directive.
- Compliance with the Essential Health and Safety Requirements has been assured by compliance with EN 60079-15 and EN 60079-0.
- May have catalog numbers followed by a "K" to indicate a conformal coating option.



**ATTENTION:** This equipment is not resistant to sunlight or other sources of UV radiation.



**WARNING:** This equipment shall be mounted in an ATEX certified enclosure with a minimum ingress protection rating of at least IP54 (as defined in IEC 60529) and used in an environment of not more than Pollution Degree 2 (as defined in IEC 60664-1) when applied in Zone 2 environments. The enclosure must utilize a tool removable cover or door.

**WARNING:** This equipment shall be used within its specified ratings defined by Rockwell Automation.

**WARNING:** Provision shall be made to prevent the rated voltage from being exceeded by transient disturbances of more than 140% of the rated voltage when applied in Zone 2 environments.

**WARNING:** The secondary of a current transformer shall not be open-circuited when applied in Class I, Zone 2 environments.

**WARNING:** This equipment must be used only with ATEX certified Rockwell Automation backplanes

**WARNING:** Secure any external connections that mate to this equipment by using screws, sliding latches, threaded connectors, or other means provided with this product.

**WARNING:** Do not disconnect equipment unless power has been removed or the area is known to be nonhazardous.

## Identify Module Components

Use the figure to identify the external features of the POINT I/O™ module.

### POINT I/O DeviceNet Communication Interface Module

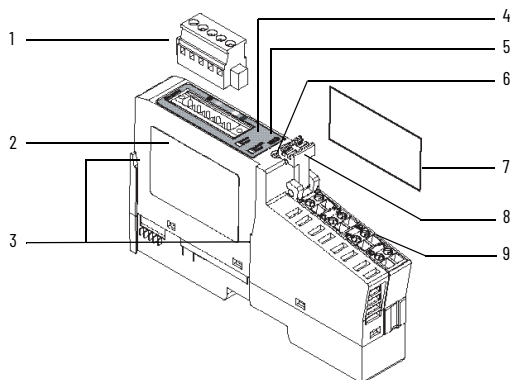

31538-M

### Module Description

|   | Description               |   | Description                    |
|---|---------------------------|---|--------------------------------|
| 1 | DeviceNet® Connector      | 6 | DIN Rail Locking Screw Orange  |
| 2 | Module Label              | 7 | Safety End Cap                 |
| 3 | Interlocking Side Pieces  | 8 | RTB Removable Handle           |
| 4 | System Power Indicator    | 9 | Removable Terminal Block (RTB) |
| 5 | DeviceNet Power Indicator |   |                                |

## Install the Module

To install the module on the DIN rail, proceed as follows.



**ATTENTION:** When you insert or remove the module while backplane power is on, an electrical arc can occur. This could cause an explosion in hazardous location installations. Be sure that power is removed or the area is nonhazardous before proceeding. Repeated electrical arcing causes excessive wear to contacts on both the module and its mating connector. Worn contacts may create electrical resistance that can affect module operation.

---

1. Position the module vertically above the DIN rail
  2. Press down firmly to install the module on the DIN rail.  
The locking mechanism will lock the module to the DIN rail.
  3. Remove the safety end cap by sliding it up to expose the backplane and power interconnections.
- 



**ATTENTION:** Do not discard the end cap. Use this end cap to cover the exposed interconnections on the last mounting base on the DIN rail. Failure to do so could result in equipment damage or injury from electric shock.

---

## **Install the Module in an Existing System**

To install a replacement module in an existing system, proceed as follows.

1. To remove the module from the DIN rail, pull up on the RTB removal handle to remove the terminal block.



**WARNING:** When you connect or disconnect the Removable Terminal Block (RTB) with field side power applied, an electrical arc can occur. This could cause an explosion in hazardous location installations.  
Be sure that power is removed or the area is nonhazardous before proceeding.

---

2. Use a small-bladed screwdriver to rotate the DIN rail locking screw to a vertical position. This releases the locking mechanism.
3. Lift straight up to remove.
4. Position the module vertically above the DIN rail.
5. Slide the module down so that the interlocking side pieces engage the adjacent module.
6. Press firmly to seat the module on the DIN rail.  
The module locking mechanism will snap into place.



## Wire the Module



**WARNING:** If you connect or disconnect wiring while the field-side power is on, an electrical arc can occur. This could cause an explosion in hazardous location installations. Be sure that power is removed or the area is nonhazardous before proceeding.

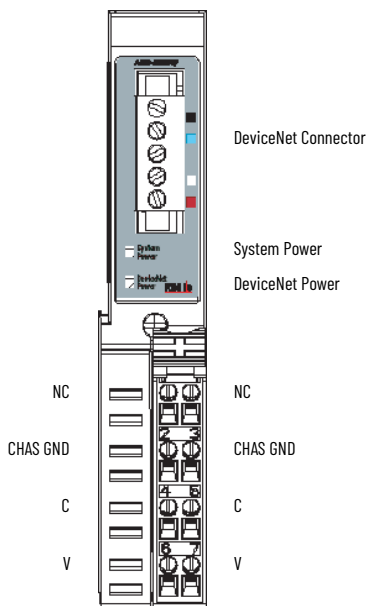

42513

NC = No Connection  
 CHAS GND = Chassis Ground  
 C = Common  
 V = Supply

## POINT I/O DeviceNet Communication Interface Module Installation Instructions

### 12/24V DC Wiring

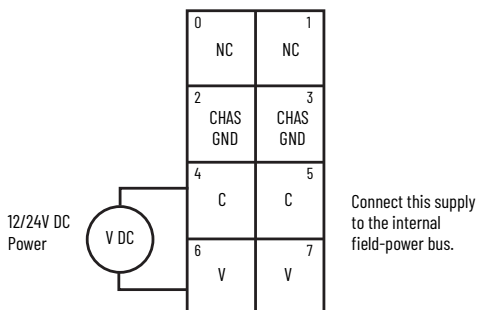

NC = No Connection  
CHAS GND = Chassis Ground  
C = Common  
V = Supply

43960

| Connect  | Terminal In | Terminal Out |
|----------|-------------|--------------|
| +V DC    | 6           | 7            |
| -V DC    | 4           | 5            |
| Chas Gnd | 2           | 3            |

12/24V DC becomes the internal field-power bus for modules to the right.

**120/240V AC Wiring**

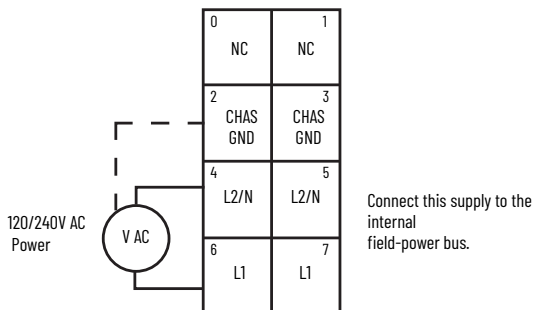

NC = No Connection  
 L2/N = Neutral, L1 = 120/240V AC  
 CHAS GND = Chassis Ground

43961

| Connect  | Terminal In | Terminal Out |
|----------|-------------|--------------|
| L1       | 6           | 7            |
| L2/N     | 4           | 5            |
| Chas Gnd | 2           | 3            |

120/240V AC becomes the internal field-power bus for modules to the right.

**DeviceNet Wiring**

DeviceNet Connection

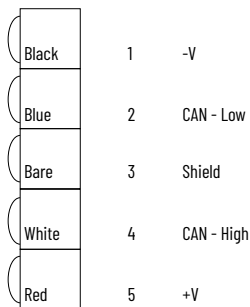

42514

## Troubleshoot with Indicators

Use the status indicators to troubleshoot your module.

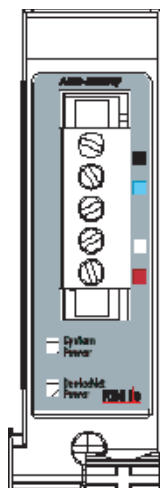

System Power

DeviceNet Power

41970

| Indicator       | Indication | Probable Cause  |
|-----------------|------------|---|
| System Power    | Off        | Not active<br>DeviceNet power is off or<br>DC-DC converter problem. |
|                 | Green      | System power is on.<br>DC-DC converter is active (5V).              |
| DeviceNet Power | Off        | Not active<br>DeviceNet power is OFF.                               |
|                 | Green      | Power is on with 24V present.                                       |

## Specifications

### Communication Interface Specifications

| Attribute              | Value  |
|------------------------|--|
| Expansion I/O Capacity | <p>Up to 17 modules, dependent on backplane bus current draw (17 times 75 mA = 1.275 A, just under the limit of 1.3 A)<br/>           The actual number of modules can vary.<br/>           Add up the current requirements of the modules you want to use to make sure they do not exceed the amperage limit of the 1734-PDN or 1734-PDNC module.</p> <p>Cat. No. POINTBus™ Current Requirements</p> <p>1734-1B275 mA<br/>           1734-1B475 mA<br/>           1734-1B875 mA<br/>           1734-1V275 mA<br/>           1734-1V475 mA<br/>           1734-0B275 mA<br/>           1734-0B475 mA<br/>           1734-0B875 mA<br/>           1734-0B2E75 mA<br/>           1734-0B2EP75 mA<br/>           1734-0B4E75 mA<br/>           1734-0B8E75 mA<br/>           1734-0V2E75 mA<br/>           1734-0V4E75 mA<br/>           1734-0W280 mA<br/>           1734-0W480 mA<br/>           1734-0X2100 mA<br/>           1734-1E2C75 mA<br/>           1734-0E2C75 mA<br/>           1734-1E2V75 mA<br/>           1734-0E2V75 mA<br/>           1734-1A275 mA<br/>           1734-1M275 mA<br/>           1734-0A275 mA<br/>           1734-1J160 mA<br/>           1734-1K160 mA<br/>           1734-1R2220 mA<br/>           1734-1T21175 mA<br/>           1734-SS110 mA<br/>           1734-232ASC75 mA<br/>           1734-VHSC5180 mA<br/>           1734-VHSC24180 mA<br/>           1734-485ASC75 mA</p> |
| Communication Rate     | <p>125K bit/s (500 m maximum)<br/>           250K bit/s (250 m maximum)<br/>           500K bit/s (100 m maximum)</p>  |

## POINT I/O DeviceNet Communication Interface Module Installation Instructions

---

### Communication Interface Specifications

| Attribute                    | Value  |
|------------------------------|--|
| DeviceNet Power Requirements | 24V DC (+4% = 25V DC max) @ 400 mA maximum   |
| DeviceNet Cable              | Allen-Bradley part number 1485C-P1-Cxxx<br>Refer to publication NETS-SG001 for more information. |
| Module Location              | Starter module - left side of 1734 system  |

### DeviceNet Power Supply Specifications

| Attribute                        | Value   |
|----------------------------------|---|
| Input Voltage Rating             | 24V DC nominal  |
| Input Voltage Range              | 11...25V DC DeviceNet specification   |
| Input Overvoltage Protection     | Reverse polarity protected  |
| Inrush Current                   | 6 A for 5 ms maximum  |
| Indicators                       | 2 green power supply status indicators:<br>System Power (POINTBus 5V power)<br>DeviceNet Power (24V from DeviceNet) |
| Supply Power and Current Ratings | DeviceNet power must be supplied by a Class 2 source  |
| Power Supply                     | User supplied power should be separate from DeviceNet power   |

**General Specifications**

| <b>Attribute</b>   | <b>Value</b>  |
|--|---|
| POINTBus Output Current, max                               | 1.3 A @ 5V DC +5% (4.75...5.25)   |
| Power Consumption  | 8.0 W @ 25V DC  |
| Power Dissipation, max                                     | 1.2 W @ 25V DC  |
| Thermal Dissipation, max                                   | 4.1 BTU/h @ 25V DC  |
| Isolation Voltage<br>(continuous-voltage withstand rating) | 50V continuous<br>Tested to withstand 2600V DC for 60 s   |
| Field Power Bus<br>Supply Current<br>Supply Voltage        | 10 A maximum<br>10...28.8V DC range,<br>120V AC or 240V AC  |
| Dimensions (HxWxD), approx.                                | 76.2 x 25.4 x 133.4 mm (3.0 x 1.0 x 5.25 in.)   |
| Enclosure Type Rating                                      | None (open-style)   |
| Wire Size  | 0.34...2.5 mm <sup>2</sup> (22...14 AWG) solid or stranded copper wire rated @ 75 °C (167 °F), or greater, 1.2 mm (3/64 in.) insulation max |
| Wiring Category <sup>(1)</sup>                             | 1 – on signal ports   |
| Terminal Base Screw Torque                                 | 0.6 Nm (7 lb•in)  |
| Weight   | 0.13 kg (0.29 lb)   |
| North American Temp Code                                   | T4A   |
| ATEX Temp Code   | T4  |

- (1) Use this Conductor Category information for planning conductor routing. Refer to Industrial Automation Wiring and Grounding Guidelines, publication [I770-4.1](#).

## POINT I/O DeviceNet Communication Interface Module Installation Instructions

### Environmental Specifications

| Attribute                | Value  |
|--------------------------|--|
| Operating Temperature    | IEC 60068-2-1 (Test Ad, Operating Cold),<br>IEC 60068-2-2 (Test Bd, Operating Dry Heat),<br>IEC 60068-2-14 (Test Nb, Operating Thermal Shock):<br>-20...55 °C (-4...131 °F)  |
| Storage Temperature      | IEC 60068-2-1 (Test Ab, Unpackaged Nonoperating Cold),<br>IEC 60068-2-2 (Test Bb, Unpackaged Nonoperating Dry Heat),<br>IEC 60068-2-14 (Test Na, Unpackaged Nonoperating Thermal Shock):<br>-40...85 °C (-40...185 °F) |
| Relative humidity        | IEC 60068-2-30 (Test Db, Unpackaged Damp Heat):<br>5...95% noncondensing   |
| Vibration                | IEC 60068-2-6 (Test Fc, Operating):<br>5 g @ 10...500 Hz   |
| Shock, operating         | IEC 60068-2-27 (Test Ea, Unpackaged Shock):<br>30 g  |
| Shock, nonoperating      | IEC 60068-2-27 (Test Ea, Unpackaged Shock):<br>50 g  |
| Emissions                | IEC 61000-6-4  |
| ESD immunity             | IEC 6100-4-2:<br>6 kV contact discharges<br>8 kV air discharges  |
| Radiated RF immunity     | IEC 61000-4-3:<br>10V/m with 1 kHz sine-wave 80% AM from 30 MHz...2000 MHz<br>10V/m with 200 Hz 50% Pulse 100% AM @ 900 MHz<br>10V/m with 200 Hz 50% Pulse 100% AM @ 1890 MHz  |
| EFT/B immunity           | IEC 61000-4-4<br>+4 kV @ 2.5 kHz on power ports<br>+2 kV @ 5 kHz on communication ports  |
| Surge transient immunity | IEC 61000-4-5:<br>±1 kV line-line (DM) and ±2 kV line-earth (CM) on signal ports<br>±2 kV line-earth (CM) on shielded ports  |
| Conducted RF immunity    | IEC 61000-4-6:<br>10 V rms with 1 kHz sine-wave 80% AM @ 150 kHz...80 MHz  |



## Certifications

| Certification (when product is marked) <sup>(1)</sup>                                  | Value   |
|--|---|
| c-UL-us  | UL Listed Industrial Control Equipment, certified for US and Canada. See UL File E65584.<br>UL Listed for Class I, Division 2 Group A,B,C,D Hazardous Locations, certified for U.S. and Canada. See UL File E194810.  |
| CE   | European Union 2014/30/EU EMC Directive, compliant with:<br>EN 61326-1; Meas./Control/Lab., Industrial Requirements<br>EN 61000-6-2; Industrial Immunity<br>EN 61000-6-4; Industrial Emissions<br>EN 61131-2; Programmable Controllers (Clause 8, Zone A & B)<br><br>European Union 2014/35/EU LVD, compliant with:<br>EN 61131-2; Programmable Controllers (Clause 11)<br><br>European Union 2011/65/EU RoHS, compliant with:<br>EN 50581; Technical documentation |
| RCM  | Australian Radiocommunications Act, compliant with:<br>EN 61000-6-4; Industrial Emissions   |
| Ex<br> | European Union 2014/34/EU ATEX Directive, compliant with:<br>EN 60079-0; General Requirements<br>EN 60079-15; Potentially Explosive Atmospheres, Protection "n"<br>II 3 G Ex nA IIC T4 Gc<br>DEMKO 04 ATEX 0330347X<br>when used at or below 60V AC or 75V DC   |
| KC   | Korean Registration of Broadcasting and Communications Equipment, compliant with:<br>Article 58-2 of Radio Waves Act, Clause 3  |
| EAC  | Russian Customs Union TR CU 020/2011 EMC Technical Regulation<br>Russian Customs Union TR CU 004/2011 LV Technical Regulation   |
| DeviceNet  | ODVA conformance tested to DeviceNet specifications   |

- (1) See the Product Certification link at <https://www.rockwellautomation.com/global/certification/overview.page> for Declaration of Conformity, Certificates, and other certification details.

**Notes:**

**Notes:**

## Rockwell Automation Support

Use these resources to access support information.

|   |  |  |
|---|--|--|
| <b>Technical Support Center</b>                         | Find help with how-to videos, FAQs, chat, user forums, and product notification updates.           | <a href="http://rok.automation.com/support">rok.automation.com/support</a>             |
| <b>Knowledgebase</b>                                    | Access Knowledgebase articles.   | <a href="http://rok.automation.com/knowledgebase">rok.automation.com/knowledgebase</a> |
| <b>Local Technical Support Phone Numbers</b>            | Locate the telephone number for your country.  | <a href="http://rok.automation.com/phonesupport">rok.automation.com/phonesupport</a>   |
| <b>Literature Library</b>                               | Find installation instructions, manuals, brochures, and technical data publications.               | <a href="http://rok.automation.com/literature">rok.automation.com/literature</a>       |
| <b>Product Compatibility and Download Center (PCDC)</b> | Download firmware, associated files (such as AOP, EDS, and DTM), and access product release notes. | <a href="http://rok.automation.com/pcdc">rok.automation.com/pcdc</a>                   |

## Documentation Feedback

Your comments help us serve your documentation needs better. If you have any suggestions on how to improve our content, complete the form at [rok.automation.com/docfeedback](http://rok.automation.com/docfeedback).

## Waste Electrical and Electronic Equipment (WEEE)







At the end of life, this equipment should be collected separately from any unsorted municipal waste.

Rockwell Automation maintains current product environmental compliance information on its website at [rok.automation.com/pec](http://rok.automation.com/pec).

Your comments help us serve your documentation needs better. If you have any suggestions on how to improve our content, complete the form at [rok.automation.com/docfeedback](http://rok.automation.com/docfeedback).

For technical support, visit [rok.automation.com/support](http://rok.automation.com/support).

Rockwell Otomasyon Ticaret A.Ş. Kar Plaza İş Merkezi E Blok Kat:6 34752, İçerenköy, İstanbul, Tel: +90 (216) 5698400 EEE Yönetmeliğine Uygundur

Connect with us.    

[rockwellautomation.com](http://rockwellautomation.com)

expanding human possibility™

AMERICAS: Rockwell Automation, 1201 South Second Street, Milwaukee, WI 53204-2496 USA, Tel: (1) 414.382.2000, Fax: (1) 414.382.4444

EUROPE/MIDDLE EAST/AFRICA: Rockwell Automation NV, Pegasus Park, De Kleetlaan 12a, 1831 Diegem, Belgium, Tel: (32) 2 663 0600, Fax: (32) 2 663 0640

ASIA PACIFIC: Rockwell Automation, Level 14, Core F, Cyberport 3, 100 Cyberport Road, Hong Kong, Tel: (852) 2887 4788, Fax: (852) 2508 1846

Allen-Bradley, expanding human possibility, FactoryTalk, POINT I/O, POINTBus, Rockwell Automation, and TechConnect are trademarks of Rockwell Automation, Inc.

DeviceNet is a trademark of ODVA, Inc.

Trademarks not belonging to Rockwell Automation are property of their respective companies.