

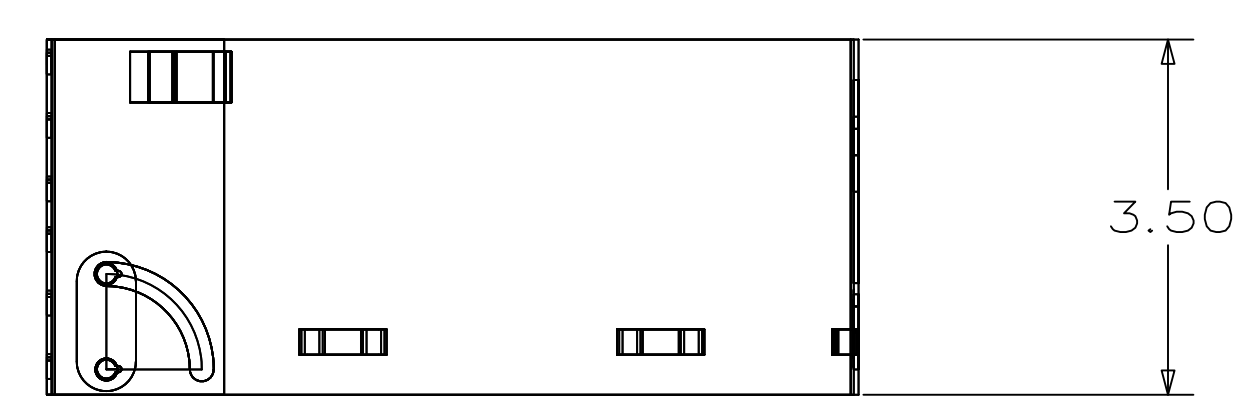

CATALOG NO.	DESCRIPTION	DIMENSION "A"
WBB24	WALL MOUNT BRACKET, 2U X 8" DEEP	4.00"
WBB28	WALL MOUNT BRACKET, 2U X 4" DEEP	8.00"

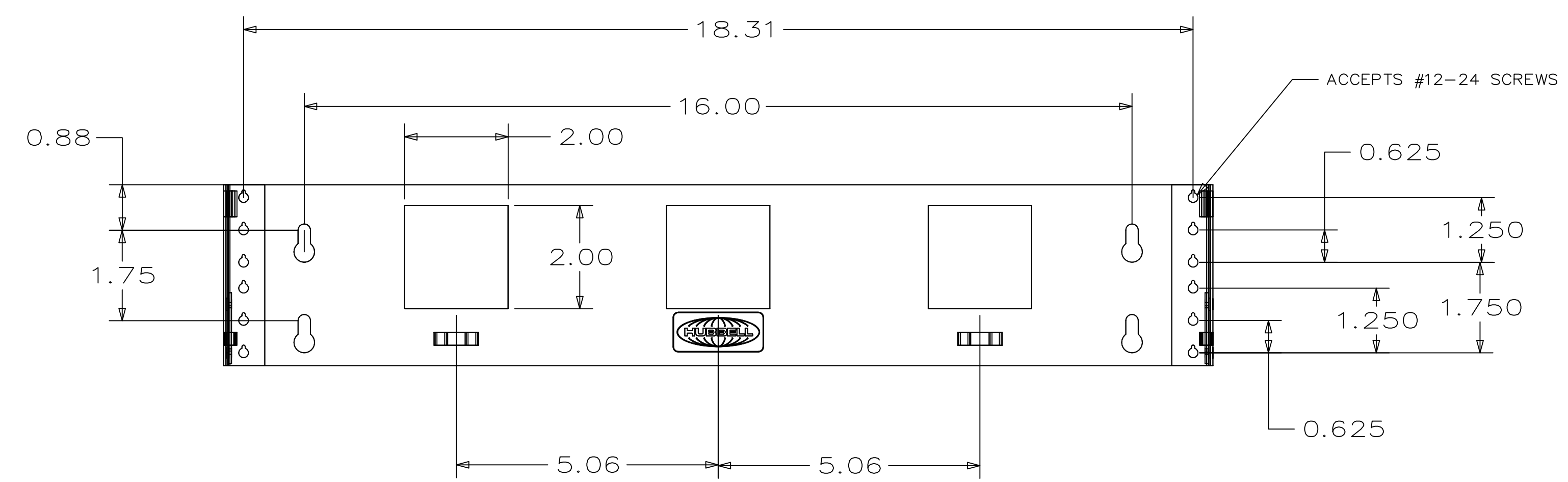
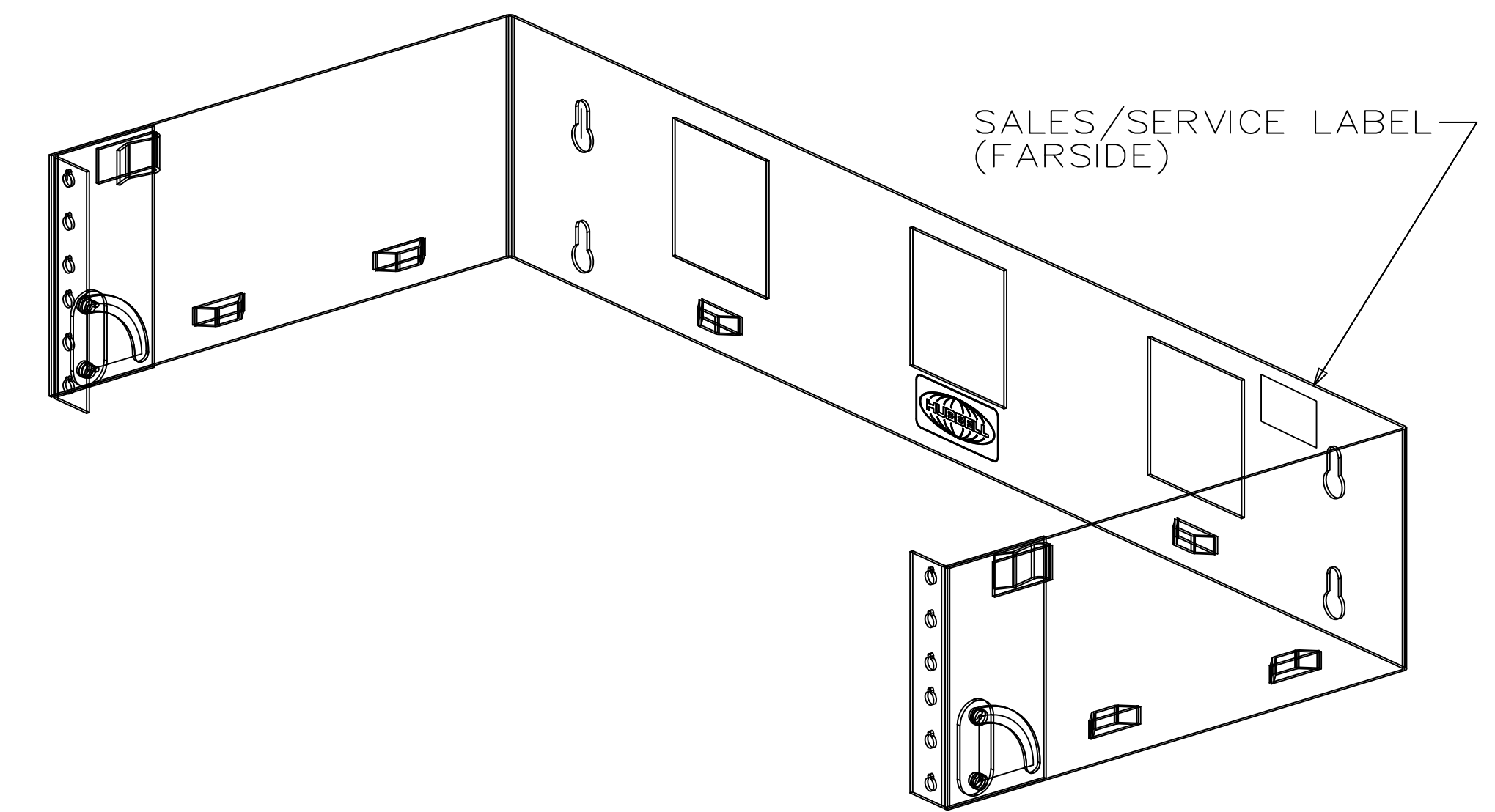
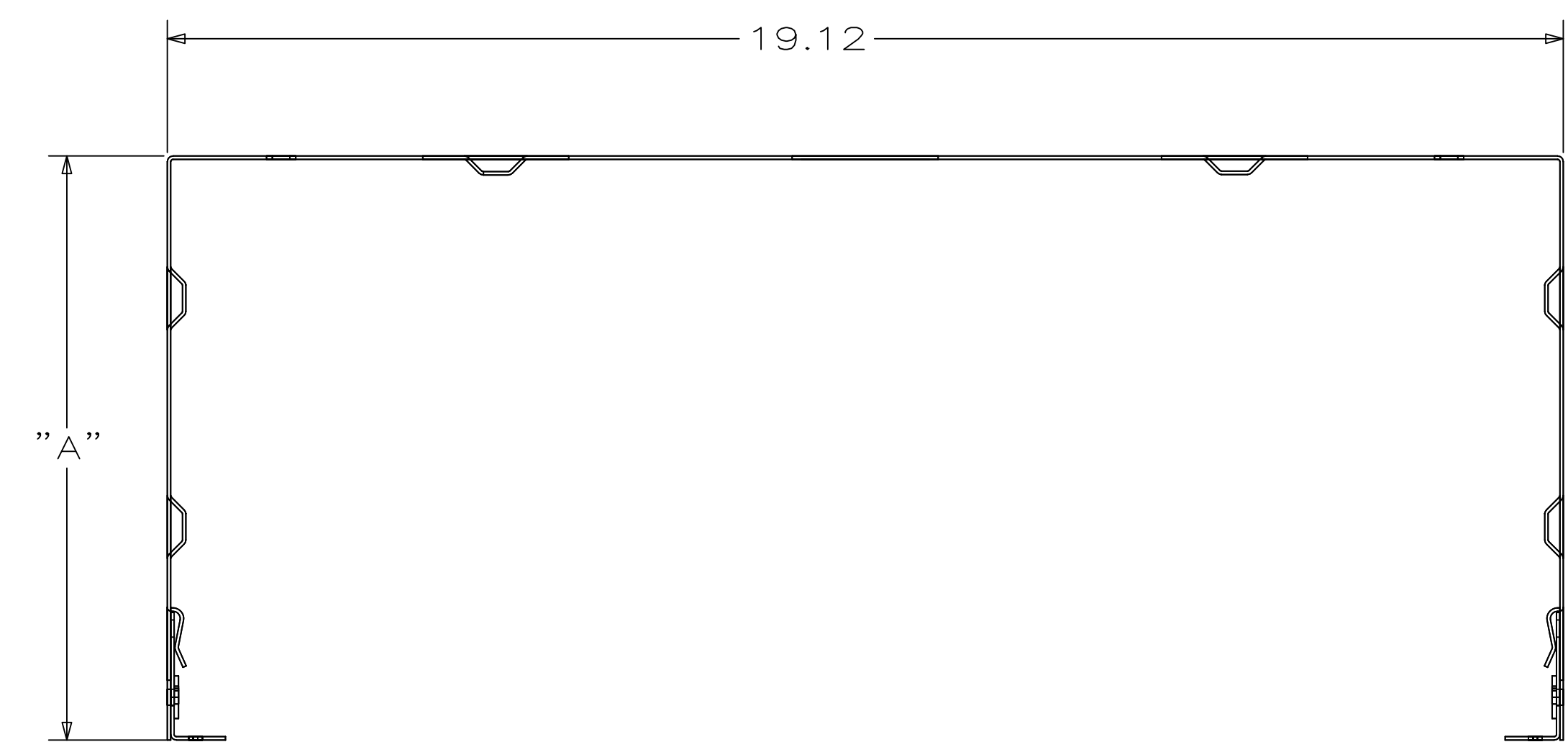

- NOTES:
- SCOPE: WALL MOUNT BRACKET IS USED FOR MOUNTING 2U HIGH 19" PATCH PANELS AND HORIZONTAL CABLE MANAGEMENT.
 - SURFACE FINISH; BLACK POWDE4R COAT
 - SPECIFICATIONS SUBJECT TO CHANGE WITHOUT NOTICE.

REV.	ECN	DATE	DESCRIPTION	CHG BY	APPD BY
1	22620	08/31/18	INITIAL RELEASE	MMA	DO

Created on V-13 UNIGRAPHICS	DIMENSIONING AND TOLERANCING PER ANSI Y14.5M-1982 UNLESS OTHERWISE SPECIFIED, DIMENSIONS ARE IN INCHES [MM]. TOLERANCES .XX = ±01 [] .XXX = ±005 [] .XXXX = ±0025 [] ANGLE TOL ±1°		PROJECT REFERENCE: 029-18	 Hubbell Premise Wiring HUBBELL INCORPORATED (Delaware) 14 Lord's Hill Road, Stonington, Connecticut 06378
	MATERIAL: COLD ROLLED STEEL		TITLE: WALL MOUNT BRACKET ASSEMBLY - 2U	
IN ACCEPTING OUR DRAWINGS, BLUEPRINTS, OR SUPPORTING DOCUMENTATION FOR QUOTATION OR OTHER PURPOSES, YOU AGREE NOT TO DISCLOSE TO OTHERS THE IDEAS, INFORMATION, OR DESIGNS SHOWN HEREIN, AND THAT YOU WILL MAKE NO USE OF SAME WITHOUT PERMISSION.		DRAWN BY: MABBY 08/29/18	SIZE: D	DRAWING NO. HWS14812C
		CHECKED BY:	SCALE: NONE	SHEET 1 OF 1
		APPROVED BY:		REV. 1